

A

PISTON PUMPS

Yuken offers low noise/high efficiency, swash plate type variable displacement piston pumps. These pumps have been developed by Yuken's leading hydraulic engineers and provide a diverse lineup to meet a wide range of application requirements.

ARL1 Series Piston Pumps

.....page A-3

- Compact and Lightweight
- Low Noise
- Covers Low Flow Rate Range
Displacement from 6.2 to 16.3 cm³/rev

A3HG Series High Pressure Variable Displacement Piston Pumps

.....page A-148

- Conforming to International Standards
- High Reliability
- High Pressure : 35 MPa

AR Series Variable Displacement Piston Pumps

.....page A-12

- Compact
- Low Noise
- High Reliability

A3HM Series High Pressure Variable Displacement Piston Pumps

.....page A-202

- Compact and Lightweight
- High Pressure : 35 MPa
- Available in a wide range of displacements

A Series Variable Displacement Piston Pumps

.....page A-22

- A variety of control methods are supported
Eleven types of unique control methods are available. These control types range from standard pressure compensator control to proportional solenoid pressure/flow control which integrate amplifiers and sensors.
- Available in a wide range of displacements
Models are available in displacements ranging of 10 to 145 cm³/rev.

AZH Series High Pressure Variable Displacement Piston Pumps

.....page A-204

- High Pressure : Rated 35 MPa, Max. 40MPa
- Large Volume Displacement : 180/270 cm³/rev
- Compatible With Combined Pumps

A3H Series High Pressure Variable Displacement Piston Pumps...page A-111

Variable displacement piston pumps offer high pressure, high performance in a simple and compact package.

- High Pressure : 35MPa
- High Volumetric Efficiency
These pumps maintain a high volumetric efficiency, even at a pressure of 35 MPa.
- Available in a wide range of displacements
Seven models are available in displacements ranging of 16.3 to 180.7 cm³/rev

Motor-Pumps & Electric Motors

-page A-206
- Pal Pumpspage A-207
- M Series Electric Motorspage A-209

ASR Series AC Servo Motor Driven Pumps

.....page A-211

- ASE** Series AC Servo Motor Driven Pumps ...pageA-231
- ASU** Series AC Servo Motor Driven Pumps...pageA-256
- Energy Saving
- Low Noise
- High Performance

Caution

In the case of Water Glycol fluids, a slight oil leak occurs from the shaft seal part.
(Criterion: 500ml / 6 months of oil leakages.) Install a tray appropriate capacity on the pump-base, please.

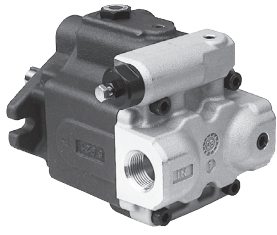

ARL1 Series Piston Pumps

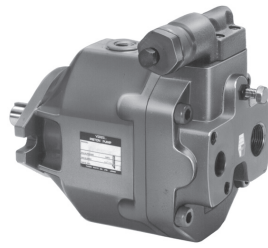

AR Series
Variable Displacement Piston Pumps

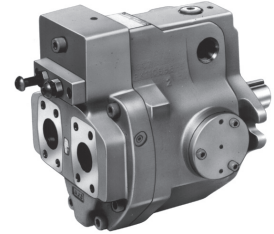

A Series
Variable Displacement Piston Pumps

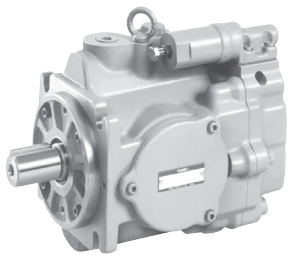

A3H Series High Pressure
Variable Displacement Piston Pumps

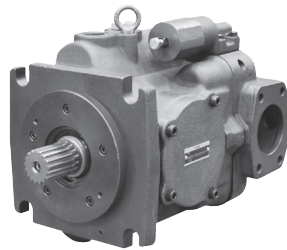

A3HG Series High Pressure
Variable Displacement Piston Pumps

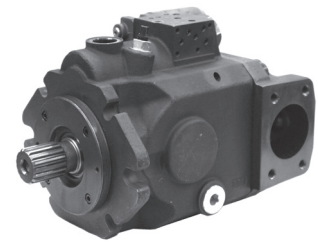

A3HM Series High Pressure
Variable Displacement Piston Pumps

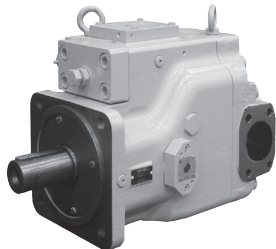

A7H Series High Pressure
Variable Displacement Piston Pumps

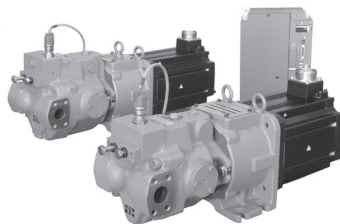

ASR Series
AC Servo Motor Driven Pumps

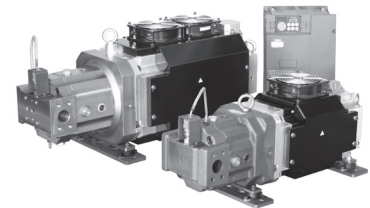

ASE Series
AC Servo Motor Driven Pumps

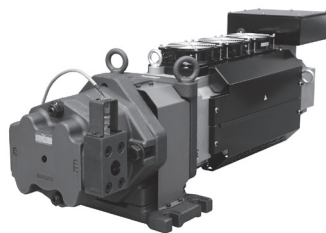

ASU Series
AC Servo Motor Driven Pumps

ARL1 Series Piston Pumps

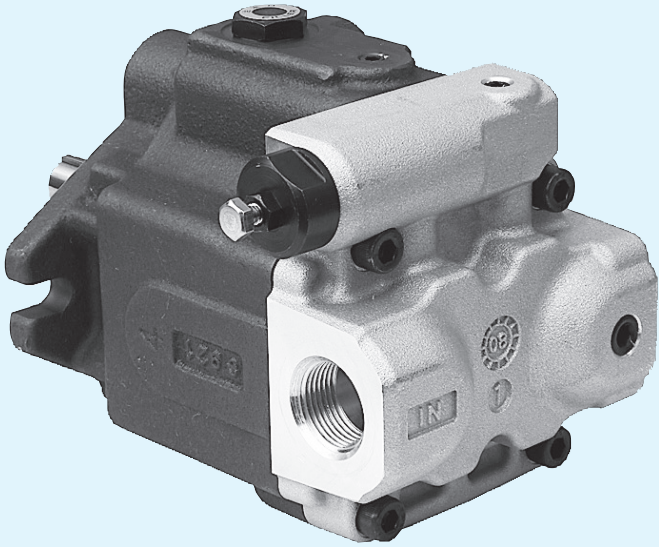

■ “ARL1” Series Piston Pumps

Pump Type	Graphic Symbol	Geometric Displacement cm ³ /rev						Maximum Operating Pressure MPa	Page		
		1	2	5	10	20	50			100	150
ARL1 Series Piston Pump				ARL1-6					7	A-6	
				ARL1-8							
				ARL1-12							
				ARL1-16							

Hydraulic Fluids

Hydraulic Fluids

Use petroleum base oils such as anti-wear type hydraulic oils equivalent to ISO VG-32 or 46. The recommended viscosity range is from 20 to 400 mm²/s and temperature range is from 0 to 60 °C, both of which have to be satisfied for the use of the above hydraulic oils.

Control of Contamination

Due caution must be paid to maintaining control over contamination of the operating oil which can otherwise lead to breakdowns and shorten the life of the unit.

Please maintain the degree of contamination within NAS Grade 10.

The suction port must be equipped with at least a 100 μm (150 mesh) reservoir type filter and the return line must have a line type filter of under 10 μm.

Instructions

Mounting

When installing the pump the filling port should be positioned upwards.

Alignment of Shaft

Employ a flexible coupling whenever possible, and avoid any stress from bending or thrust.

Maximum permissible misalignment is less than 0.1 mm TIR and maximum permissible misangular is less than 0.2°.

Suction Pressure

Permissible suction pressure at inlet port of the pump is between -16.7 and +50 kPa.

For piping to the suction port, use the pipes of the same diameter as that of the specified pipe flange to be used.

Make sure that the height of the pump suction port is within one meter from the oil level in the reservoir.

Hints on Piping

When using steel pipes for the suction or discharge ports, excessive load from the piping to the pump generates excessive noise.

Whenever there is fear of excessive load, please use rubber hoses.

Suction Piping

In case the pump is installed above the oil level, the suction piping and suction line filter should be located lower than the pump position to prevent air in the suction line.

Drain Piping

Install drain piping according to the chart and ensure that pressure within the pump housing should be maintained at a normal pressure of less than 0.1 MPa and surge pressure of less than 0.5 MPa.

Length of piping should be less than 1 m, and the pipe end should be submerged in oil.

In case ARL1 pump, a screw-in torque of fitting is 55 to 75 Nm. Do not apply bending and thrust torque to the fitting.

[Recommended Drain Piping Size]

Model	Fitting Size	Inside Dia. of Pipe
ARL1	3/8	10 mm

Bleeding Air

It may be necessary to bleed air from pump case and outlet line to remove causes of vibration. An air bleed valve (Model Number ST1004-*-10*, Page A-259) is recommended for this purpose.

Starting

Before first starting, fill pump case with clean operating oil via the filling port.

In order to avoid air blockage when first starting, adjust the control valves so that the discharged oil from the pump is returned direct to the reservoir or the actuator moves in a free load.

[Volume of Pre-fill Oil Required]

Model	Volume cm ³
ARL1	285

Setting Discharge Pressure and Delivery

At the time of shipment, the unit has been preset to maximum delivery and minimum discharge pressure.

Adjust the preset delivery and pressure to meet your system requirements.

Adjustment of Discharge Pressure

Turning the adjustment screw clockwise, increases pressure.

[Volume adjusted by each full turn of the pressure adjustment screw]

Model Numbers	Adjustment Volume MPa
ARL1	1.5

Displacement Adjustment Function

This pump does not have a displacement adjustment function.

Install a flow control valve, if necessary.

ARL1 Series Piston Pumps

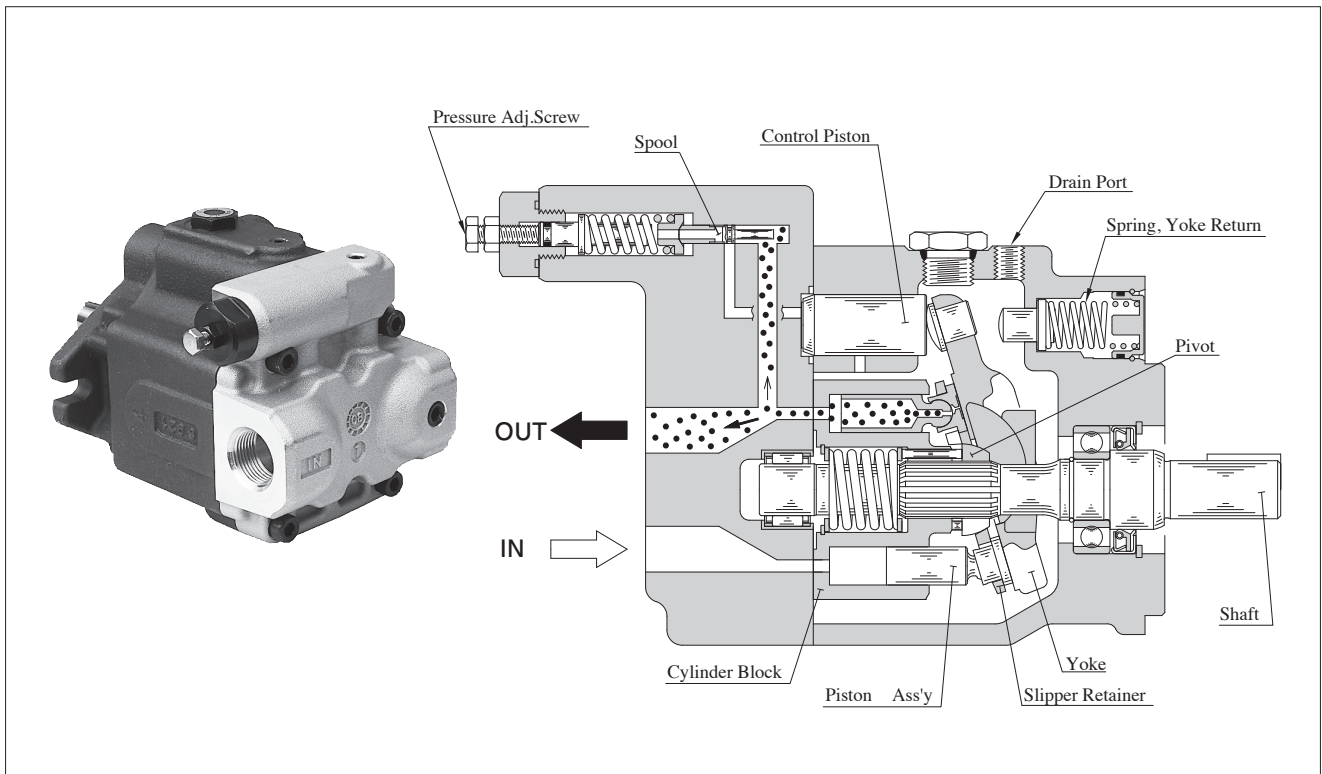

■ Features

- **Low noise and high reliability based on the long established experience**
 The noise at full cut-off with a pressure of 7 MPa, pump rotational speed of 1500 r/min, and measured distance of 1 m is as low as 55 dB(A) (representative value of ARL1-16). This series also has a high reliability based on Yuken's long-time experience of manufacturing piston pumps.
- **Lightweight and compact**
 Compared to the AR Series Variable Displacement Piston Pumps, this series is reduced by 40 % both in mass and volume, realizing a greatly lightweight and compact design.

ARL1 Series Piston Pumps, Pressure Compensator Type

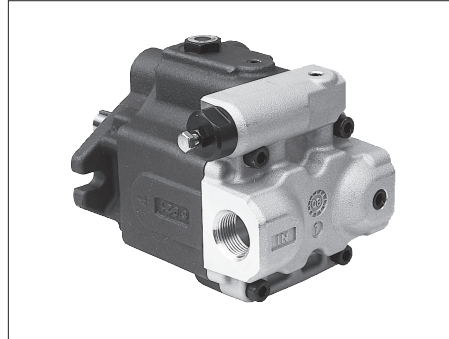

Graphic Symbol

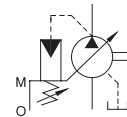

Specifications

Model Numbers	Geometric Displacement cm ³ /rev	Minimum Adj. Pressure MPa	Max. Operating Pressure MPa	Shaft Speed Range r/min		Approx. Mass kg
				Max.	Min.	
ARL1-6 *R01 *-10	6.2	1.2	7	1800	600	6.8 (Flange Mtg.) 9.0 (Foot Mtg.)
ARL1-8 *R01 *-10	8.5					
ARL1-12 *R01 *-10	12.3					
ARL1-16 *R01 *-10	16.3					

Model Number Designation

ARL1	-6	-F	R	01	S	-10
Series Number	Geometric Displacement	Mounting	Direction of Rotation	Control Type	Port Position	Design Number
ARL1	6 : 6.2 cm ³ /rev 8 : 8.5 cm ³ /rev 12 : 12.3 cm ³ /rev 16 : 16.3 cm ³ /rev	F : Flange Mtg. L : Foot Mtg.*	(Viewed from Shaft End) R : Clockwise	01 : Pressure Compensator Type	S : Side Port (Standard) A : Suction Port Position: Down Wards	10

* Foot mounting is available only for side ported type.

Typical Performance Characteristics of **ARL1** at Viscosity 32 mm²/s [ISO VG 32 Oils, 40°C]

● **ARL1-6**

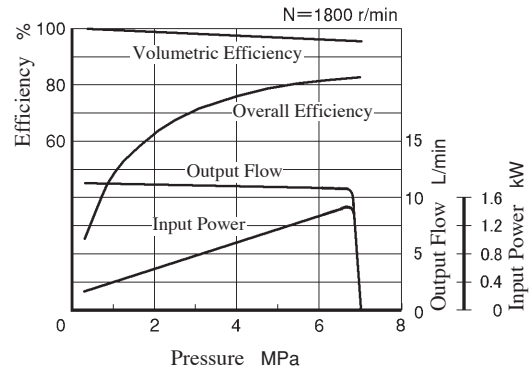
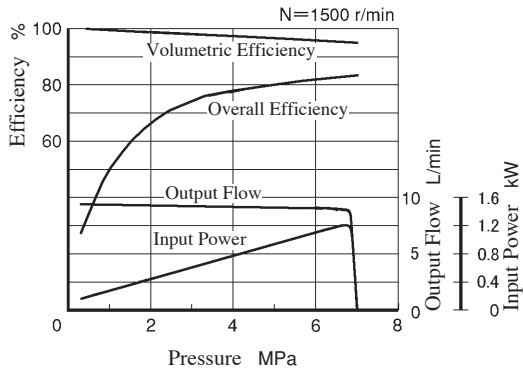

● **ARL1-8**

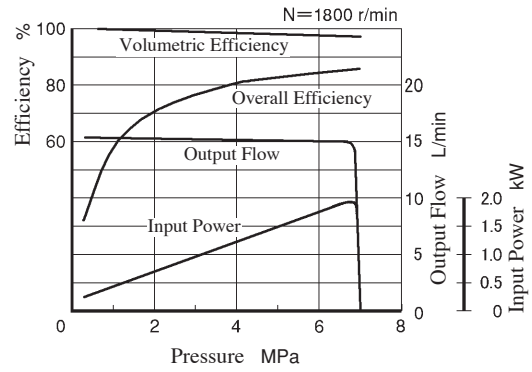
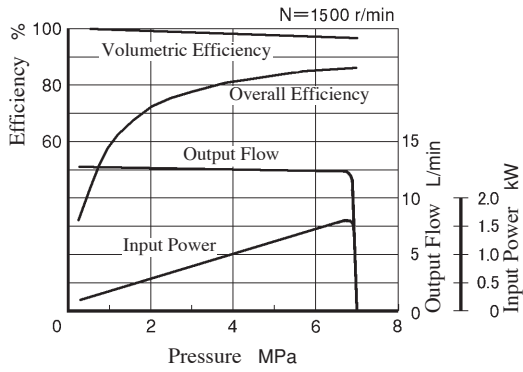

● **ARL1-12**

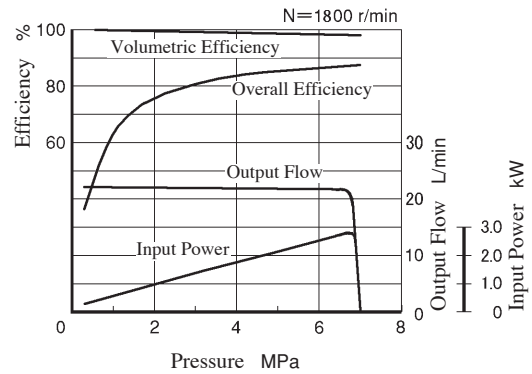
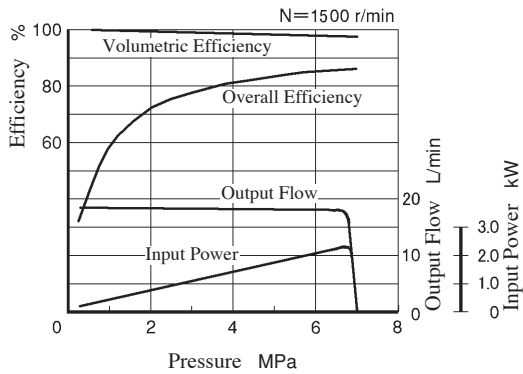

● **ARL1-16**

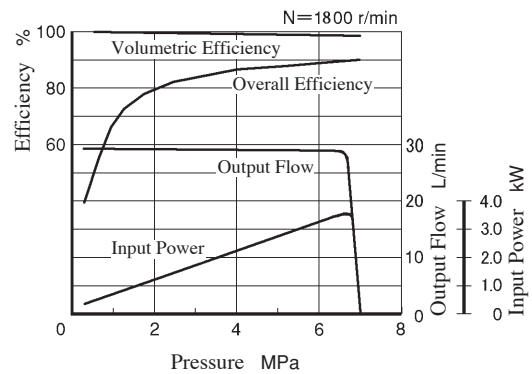
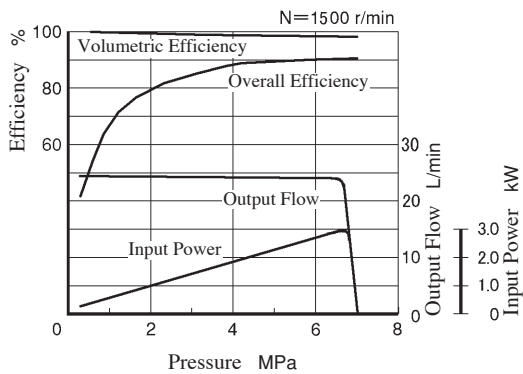

Typical Performance Characteristics of ARL1 at Viscosity 32 mm²/s [ISO VG 32 Oils, 40°C]

Full Cut-off Power

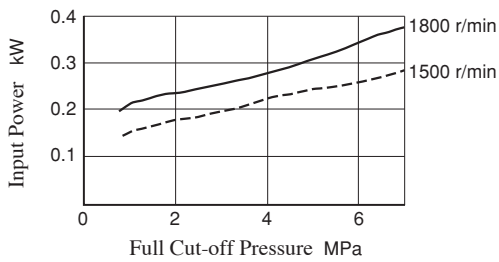

Drain

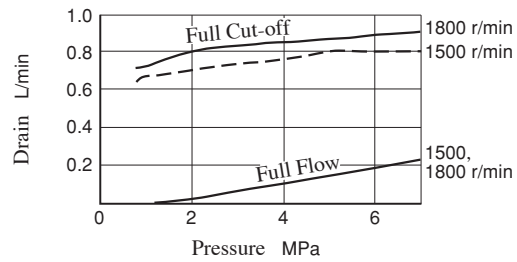

Noise Level [One meter horizontally away from pump head cover]

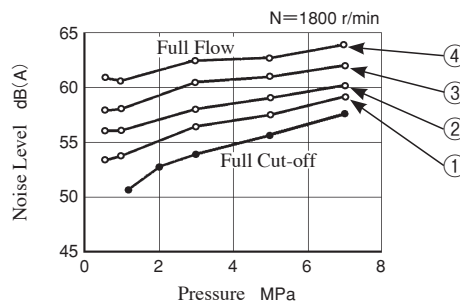
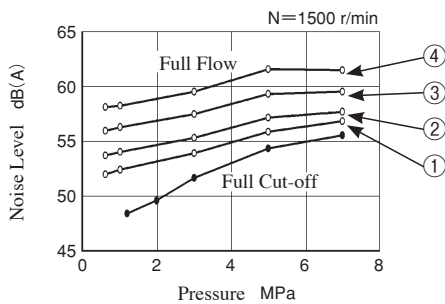

No.	Displacement
①	q = 6.2 cm ³ /rev
②	q = 8.5 cm ³ /rev
③	q = 12.3 cm ³ /rev
④	q = 16.3 cm ³ /rev

Response Characteristics Change in Accordance with Circuits and Operating Conditions

Test Circuit and Conditions

Circuit

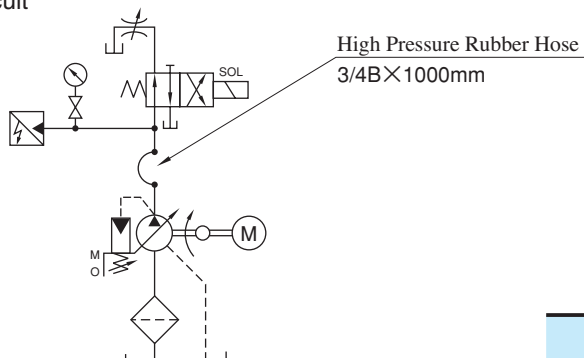

Conditions

Shaft Speed : 1500 r/min
 Hydraulic Fluid : ISO VG32 Oil
 Oil Temperature : 40 °C (Viscosity 32 mm²/s)

Result of Measurement

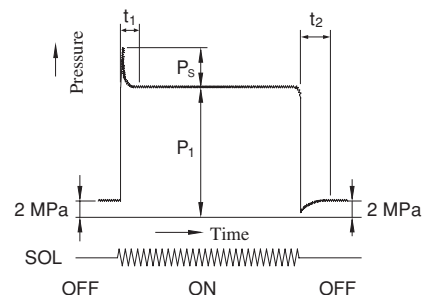

Model	Full Cut-off Pressure P ₁ MPa	Response Time ms		Overshoot Pressure P _s MPa
		t ₁	t ₂	
ARL1	7	180	125	2.5

Side Port Type

ARL1- *-FR01S

ARL1- *-LR01S

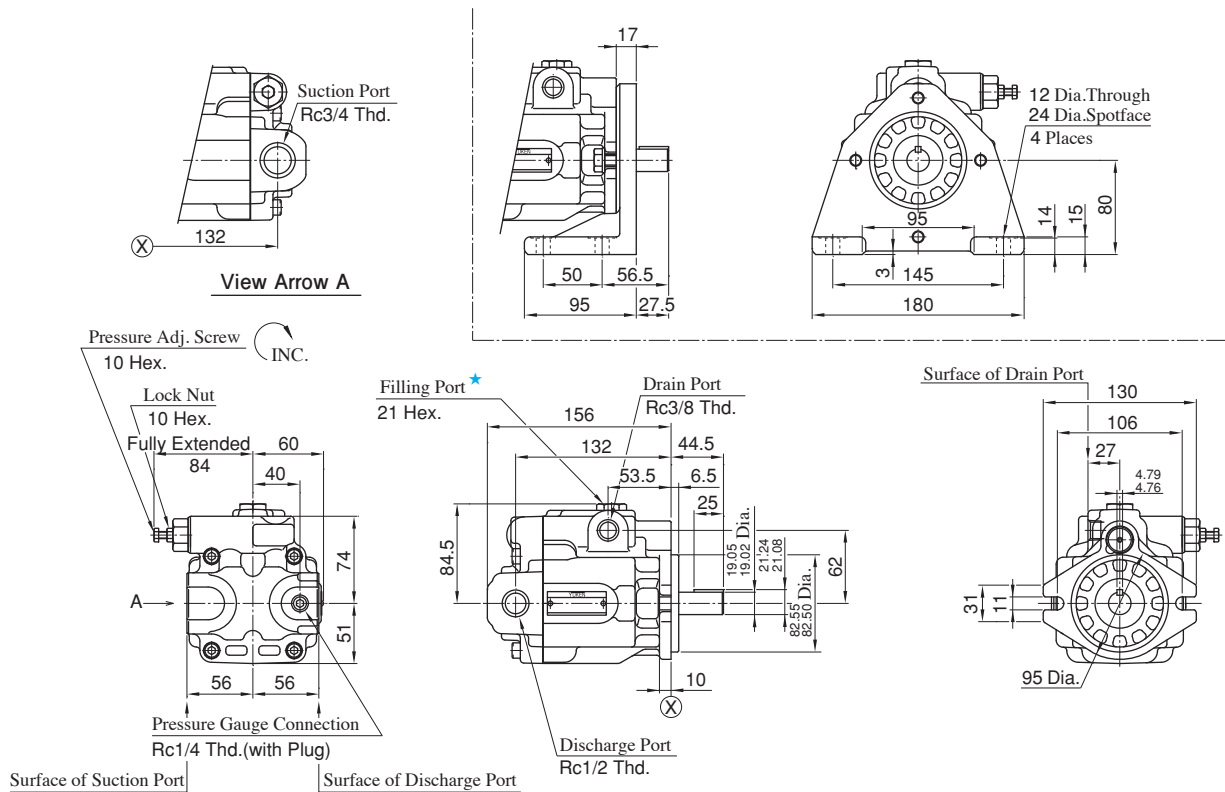

★ Install the pump so that the “Filling Port” is at the top.

Suction Port Position : Down Wards

ARL1- *-FR01A

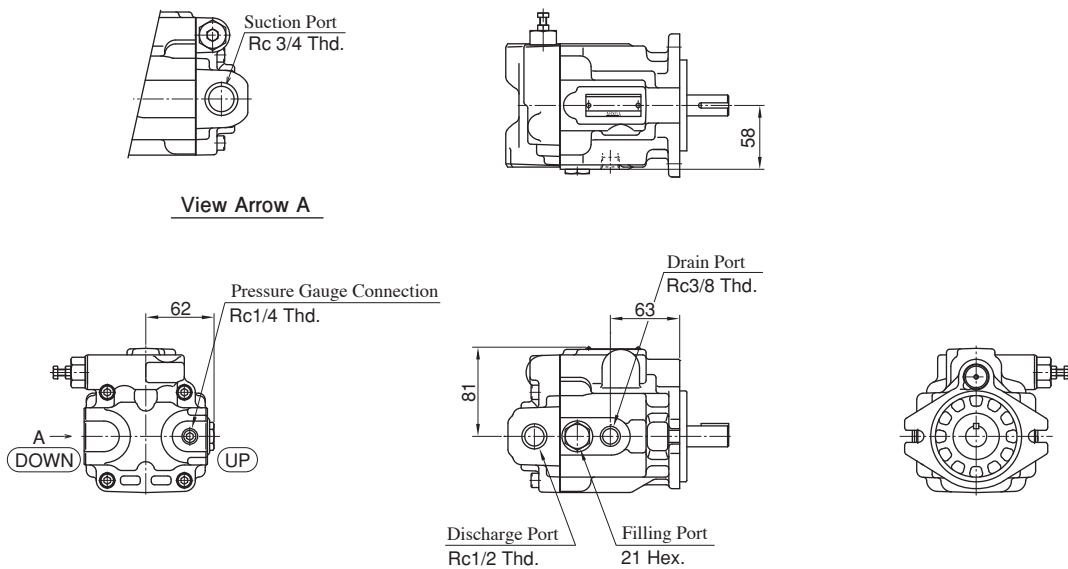

● For other dimensions, refer to “Side Port Type”.

Spare Parts List

ARL1-6/8/12/16- * R01

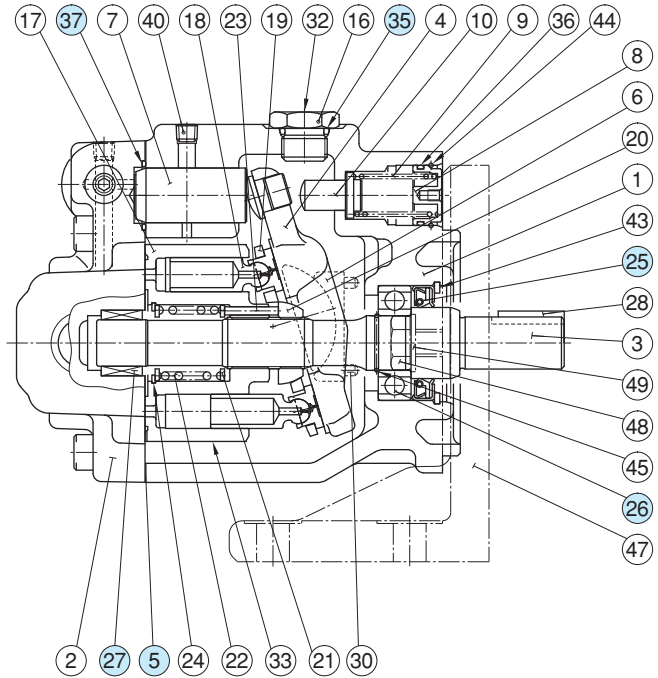
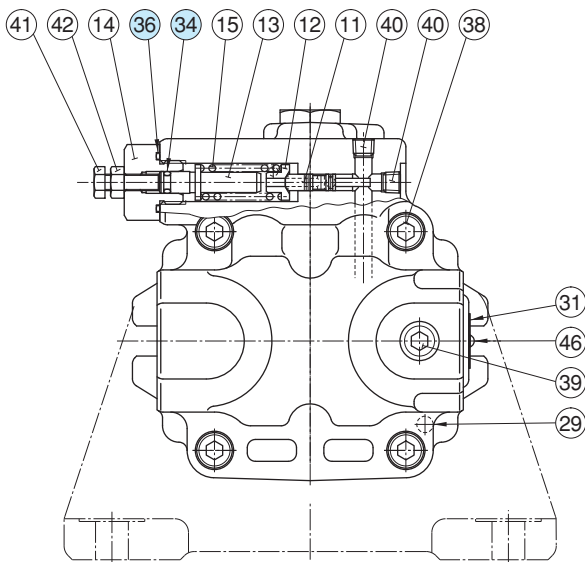

List of Seals and Bearings

Item	Name of Parts	Part Numbers	Qty.
5	Gasket	1202-PK314357-5	1
25	Oil Seal	TK280035-7	1
26	Bearing	1202-PK413170-2	1
27	Bearing	1202-PK413171-0	1
34	O-Ring	OR NBR-70-1 P5-N	1
35	O-Ring	OR NBR-90 P14-N	1
36	O-Ring	AS 568-018 (NBR-70-1)	2
37	O-Ring	AS 568-020 (NBR-90)	1

AR Series Variable Displacement Piston Pumps

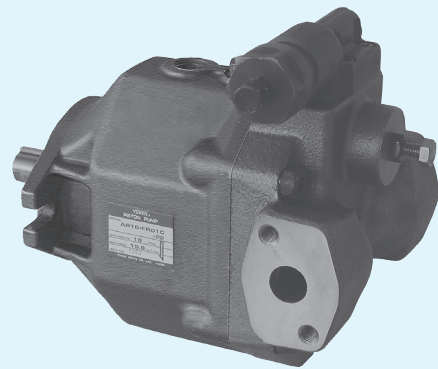
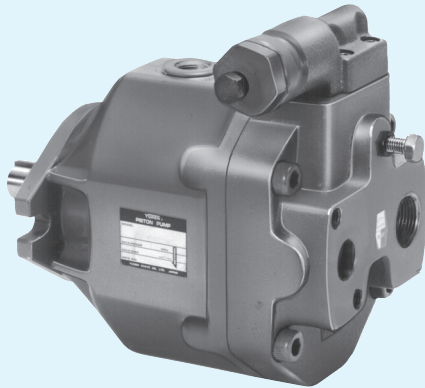

■ “AR” Series Variable Displacement Piston Pumps

Pump Type	Graphic Symbol	Geometric Displacement cm ³ /rev						Maximum Operating Pressure MPa	Page
		1	2	5	10	20	50		
 AR Series Variable Displacement Piston Pumps					AR16 AR22			16	A-15

Hydraulic Fluids

Hydraulic Fluids

Use petroleum base oils such as anti-wear type hydraulic oils equivalent to ISO VG-32 or 46. The recommended viscosity range is from 20 to 400 mm²/s and temperature range is from 0 to 60 °C, both of which have to be satisfied for the use of the above hydraulic oils.

Control of Contamination

Due caution must be paid to maintaining control over contamination of the operating oil which can otherwise lead to breakdowns and shorten the life of the unit.

Please maintain the degree of contamination within NAS Grade 10.

The suction port must be equipped with at least a 100 μm (150 mesh) reservoir type filter and the return line must have a line type filter of under 10 μm.

Instructions

Mounting

When installing the pump the filling port should be positioned upwards.

Alignment of Shaft

Employ a flexible coupling whenever possible, and avoid any stress from bending or thrust.

Maximum permissible misalignment is less than 0.1 mm TIR and maximum permissible misangular is less than 0.2°.

Suction Pressure

Permissible suction pressure at inlet port of the pump is between -16.7 and +50 kPa .

For piping to the suction port, use the pipes of the same diameter as that of the specified pipe flange to be used.

Make sure that the height of the pump suction port is within one meter from the oil level in the reservoir.

Hints on Piping

When using steel pipes for the suction or discharge ports, excessive load from the piping to the pump generates excessive noise.

Whenever there is fear of excessive load, please use rubber hoses.

Suction Piping

In case the pump is installed above the oil level, the suction piping and suction line filter should be located lower than the pump position to prevent air in the suction line.

Drain Piping

Install drain piping according to the chart and ensure that pressure within the pump housing should be maintained at a normal pressure of less than 0.1 MPa and surge pressure of less than 0.5 MPa.

Length of piping should be less than 1 m, and the pipe end should be submerged in oil.

In case AR16 and AR22 pump, a screw-in torque of fitting is 40 to 50 Nm. Do not apply bending and thrust torque to the fitting.

[Recommended Drain Piping Size]

Model	Fitting Size	Inside Dia. of Pipe
AR16, AR22	3/8 (Inside Dia. 8.5 mm or more)	10 mm

Bleeding Air

It may be necessary to bleed air from pump case and outlet line to remove causes of vibration. An air bleed valve (Model Number ST1004-*-10*, Page A-259) is recommended for this purpose.

Starting

Before first starting, fill pump case with clean operating oil via the filling port.

In order to avoid air blockage when first starting, adjust the control valves so that the discharged oil from the pump is returned direct to the reservoir or the actuator moves in a free load.

[Volume of Pre-fill Oil Required]

Model	Volume cm ³
AR16 AR22	430

Setting Discharge Pressure and Delivery

At the time of shipment, the unit has been preset to maximum delivery and minimum discharge pressure.

Adjust the preset delivery and pressure to meet your system requirements.

Adjustment of Discharge Pressure

Turning the adjustment screw clockwise, increases pressure.

[Volume adjusted by each full turn of the pressure adjustment screw]

Model Numbers	Adjustment Volume MPa
AR16/AR22-FR01B	2.9
AR16/AR22-FR01C	5.4

Adjustment of Delivery

Turning the delivery adjustment screw clockwise, decreases delivery.

[The minimum adjustable flow and adjustable volume of each full turn of the delivery adjustment screw]

Model Numbers	Adjustable volume with each full turn of the adjustment screw cm ³ /rev	Minimum Adjustable Flow cm ³ /rev
AR16	1.5	6
AR22	2.1	8.5

AR Series Variable Displacement Piston Pumps

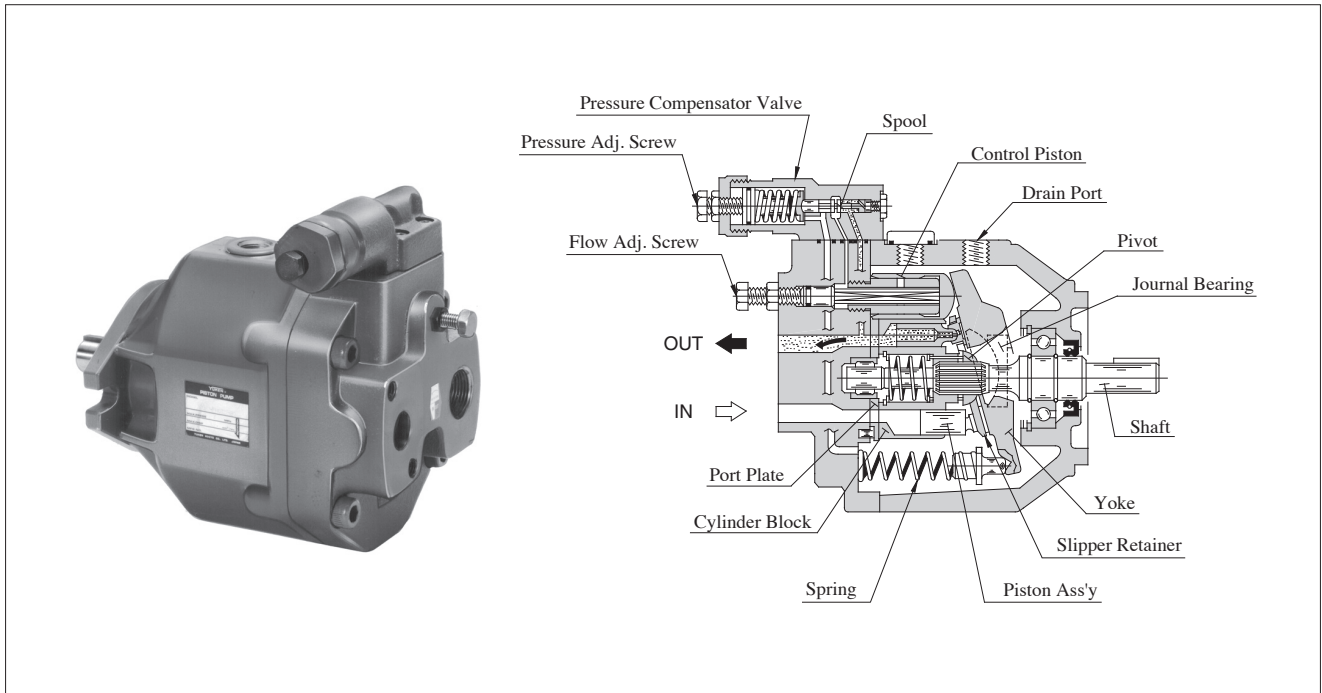

Features

Smaller in Size and Lighter in Mass

As indicated in the dimensional comparison presented below, the AR16 is smaller than the A16 (32 design). Also, the mass of AR16 is substantially lighter than the A16.

Low Noise

The noise level of AR16 has been reduced at full flow and full cut-off compared with that of the excellent A16 quiet pump.

[Comparison of "AR16" with "A16"]

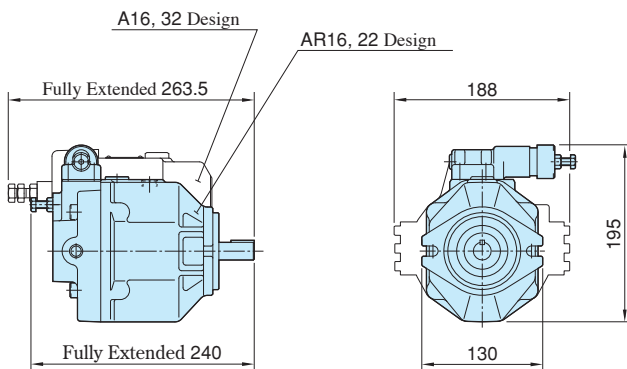

"AR16" Type Noise Level Characteristics (Example)

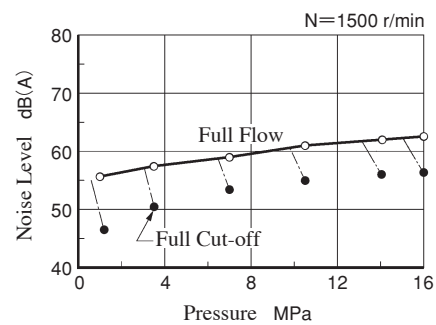

High Reliability

Since it uses the internal parts of "A" series piston pumps that it belongs to abundant experience in sales performance with high reliability.

AR Series Variable Displacement Piston Pumps, Pressure Compensator Type

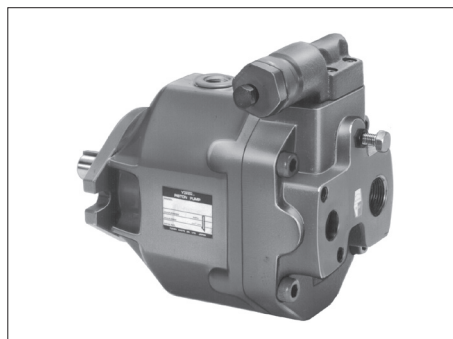

Graphic Symbol

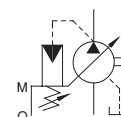

Specifications

Model Numbers	Geometric Displacement cm ³ /rev	Min. Adj. Flow cm ³ /rev	Operating Pressure MPa		Shaft Speed Range r/min		Approx. Mass kg
			Rated	Intermittent [★]	Max.	Min.	
AR16-FR01 * * -22	15.8	6.0	16		1800	600	11.8
AR22-FR01 * * -22	22.2	8.5					12.5

★ When setting the pressure, make sure the full cut-off pressure never exceeds the maximum intermittent pressure.

Model Number Designation

AR16	-F	R	01	B	S	-22
Series Number	Mounting	Direction of Rotation	Control Type	Pres. Adj. Range	Port Position	Design Number
AR16 (15.8 cm ³ /rev)	F : Flange Mtg.	[Viewed from Shaft End]	01 : Pressure Compensator Type	B : 1.2~7 C : 2.0~16	None : Axial Port S : Side Port	22
AR22 (22.2 cm ³ /rev)		R : Clockwise (Normal)				22

Pipe Flange Kits

Pipe flange kits are available. When ordering, specify the kit number from table blow.

Pump Model Numbers	Name of Port	Pipe Flange Kit Numbers	
		Threaded Connection	Socket Welding
AR16-FR01 AR22-FR01	Suction	F5-06-A-1021	F5-06-B-1021
	Discharge	— ★	— ★

★ Discharge port is available only for the threaded connections.

Pipe Flange Kit for Suction Port : F5-06-^A/_B-1021

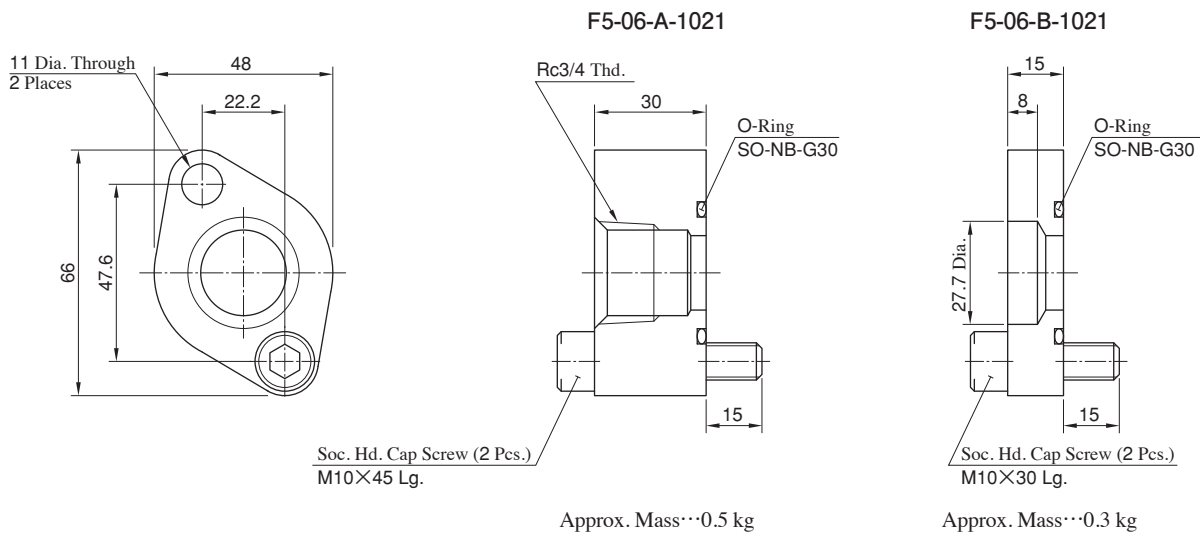

Mounting Bracket Kits

Mounting bracket available on separate order.

Pump Model Numbers	Mtg. Bracket Kit Numbers	Approx. Mass kg
AR16-FR01 AR22-FR01	LP-1A-10	2.2

Note : The mounting bracket kit consists of a mounting bracket, two hex. bolts and two plain washers.

Mtg. Bracket Kit : LP-1A-10

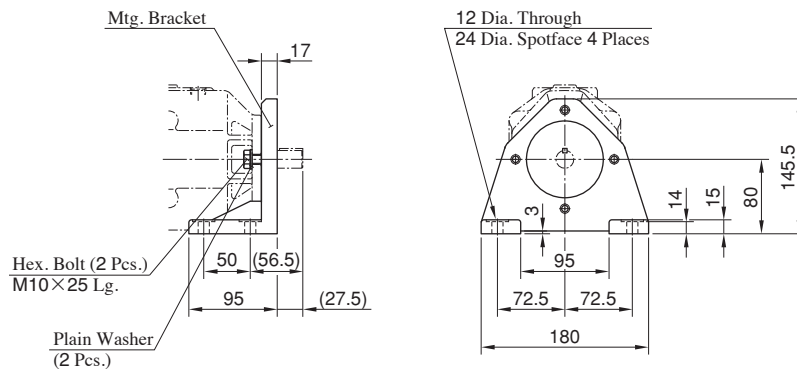

Typical Pump Characteristics of Type **AR16** at Viscosity 20 mm²/s [ISO VG32 Oils, 50°C]

Performance Characteristic Curve

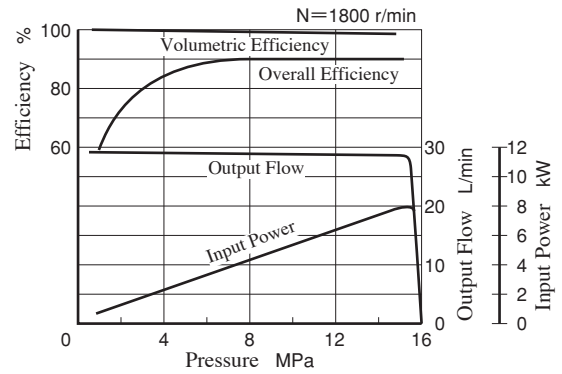
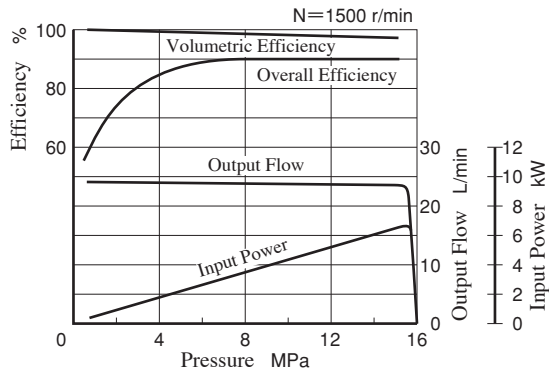

Input Power

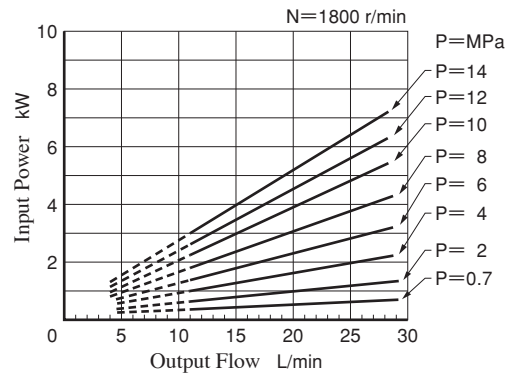
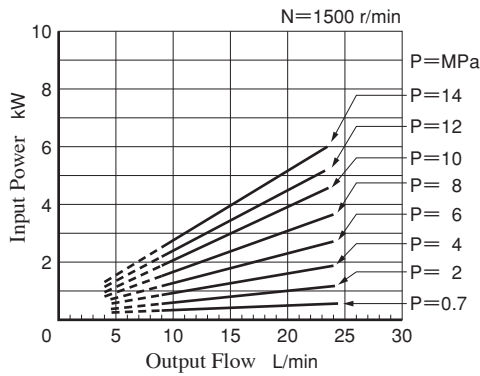

Note) The dotted line in the graph indicates less than minimum adjustable flow.

Full Cut-off Power

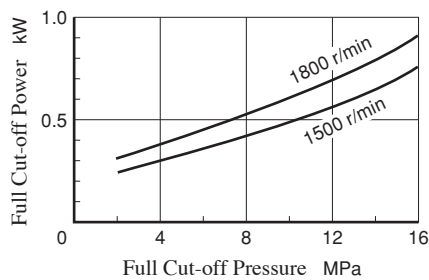

Drain

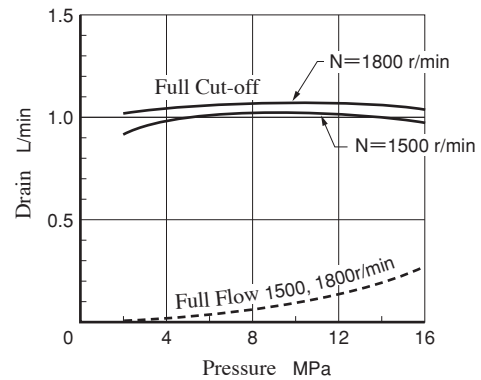

Noise Level [One meter horizontally away from pump head cover]

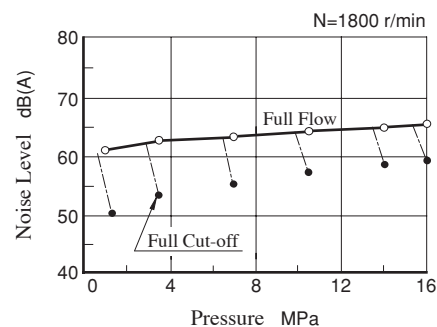
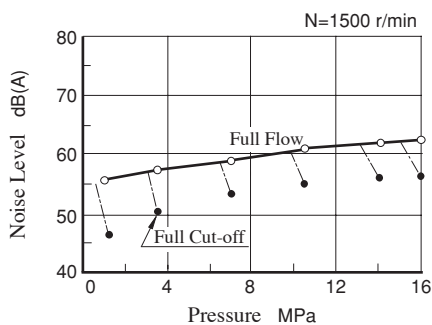

Typical Pump Characteristics of Type AR22 at Viscosity 20 mm²/s [ISO VG32 Oils, 50°C]

Performance Characteristic Curve

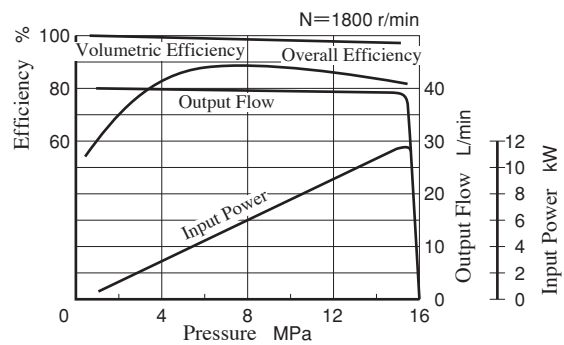
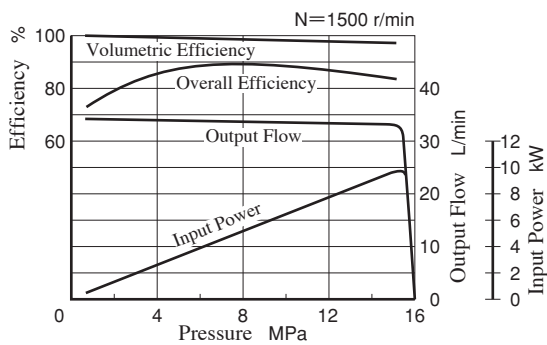

Input Power

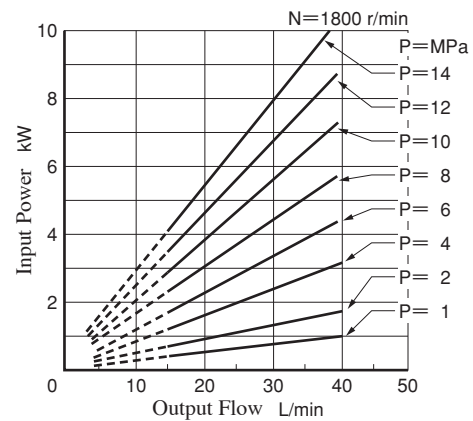
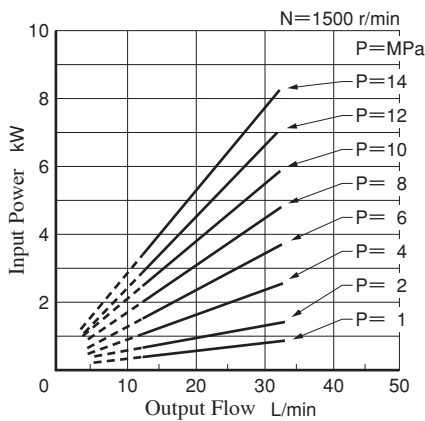

Note) The dotted line in the graph indicates less than minimum adjustable flow.

Full Cut-off Power

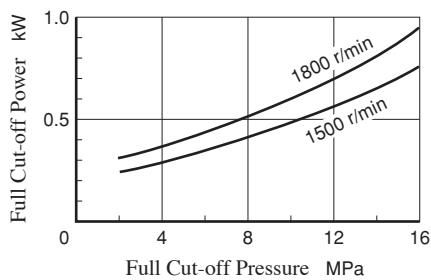

Drain

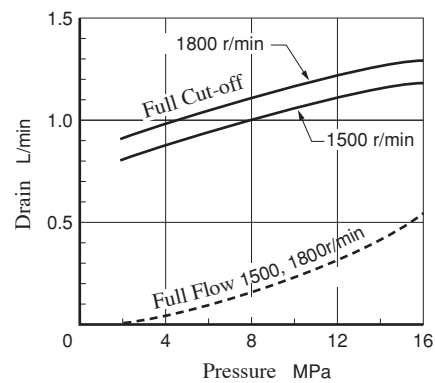

Noise Level [One meter horizontally away from pump head cover]

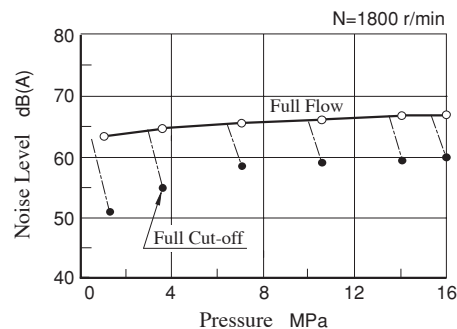
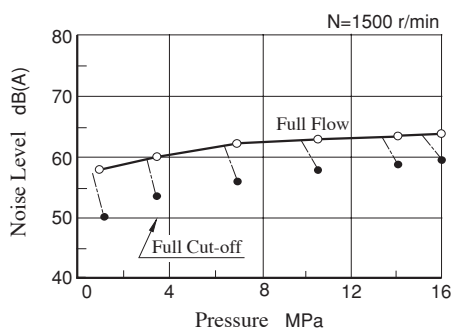

Response Characteristics Change in Accordance with Circuits and Operating Conditions.

Test Circuit Conditions

Circuit

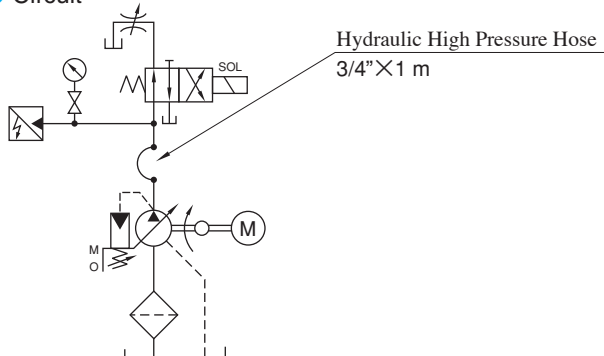

Conditions

Shaft Speed : 1500 r/min
 Hydraulic Fluid : ISO VG32 Oil
 Oil Temperature : 40 °C
 Viscosity : 32 mm²/s

Result of Measurement

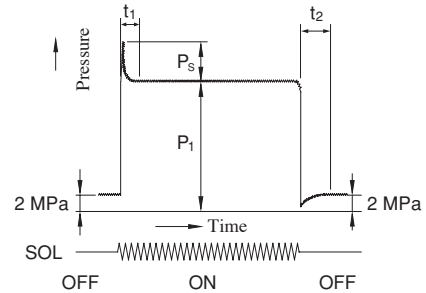

Model	Full Cut-off Pressure P ₁ MPa	Response Time ms		Overshoot Pressure P _s MPa
		t ₁	t ₂	
AR16	16	120	90	3.6
AR22		90	100	

Axial Port Type

AR16-FR01 *
AR22-FR01 *

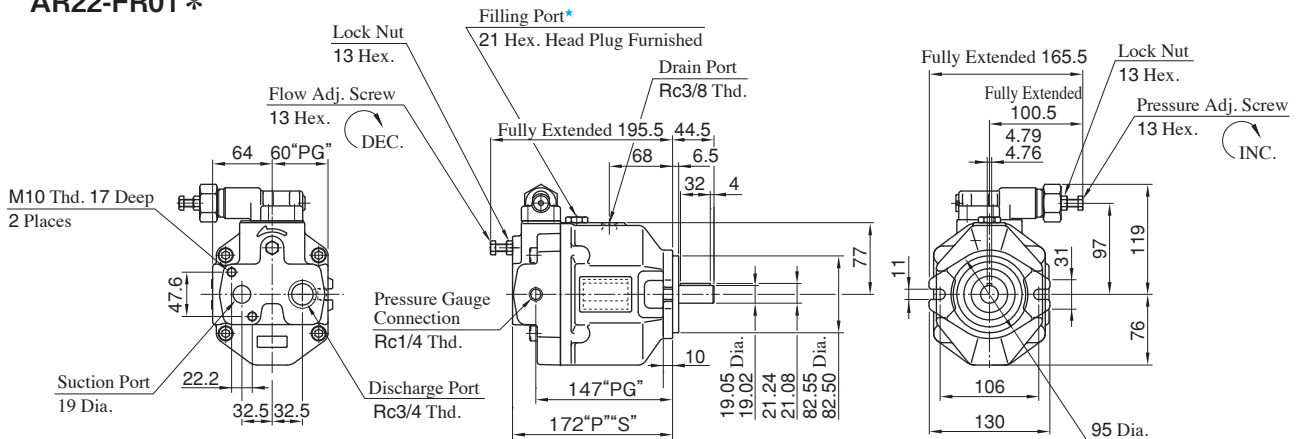

★ Install the pump so that the “Filling Port” is at the top.

Side Port Type

AR16-FR01 * S
AR22-FR01 * S

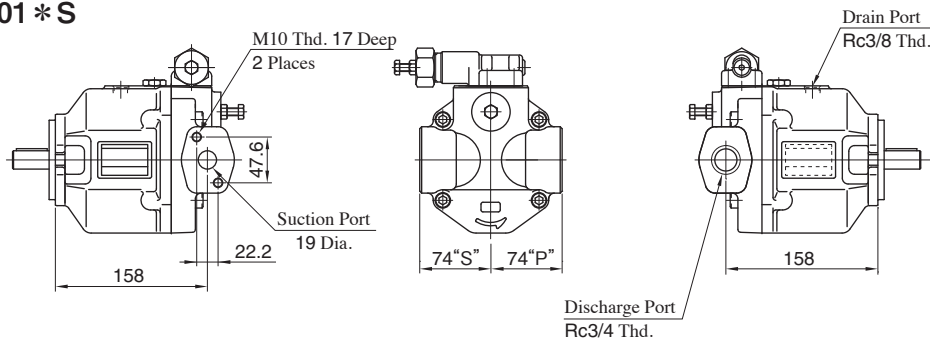

● For other dimensions, refer to “Axial port Type”.

Spare Parts List

AR16-FR01
AR22-FR01

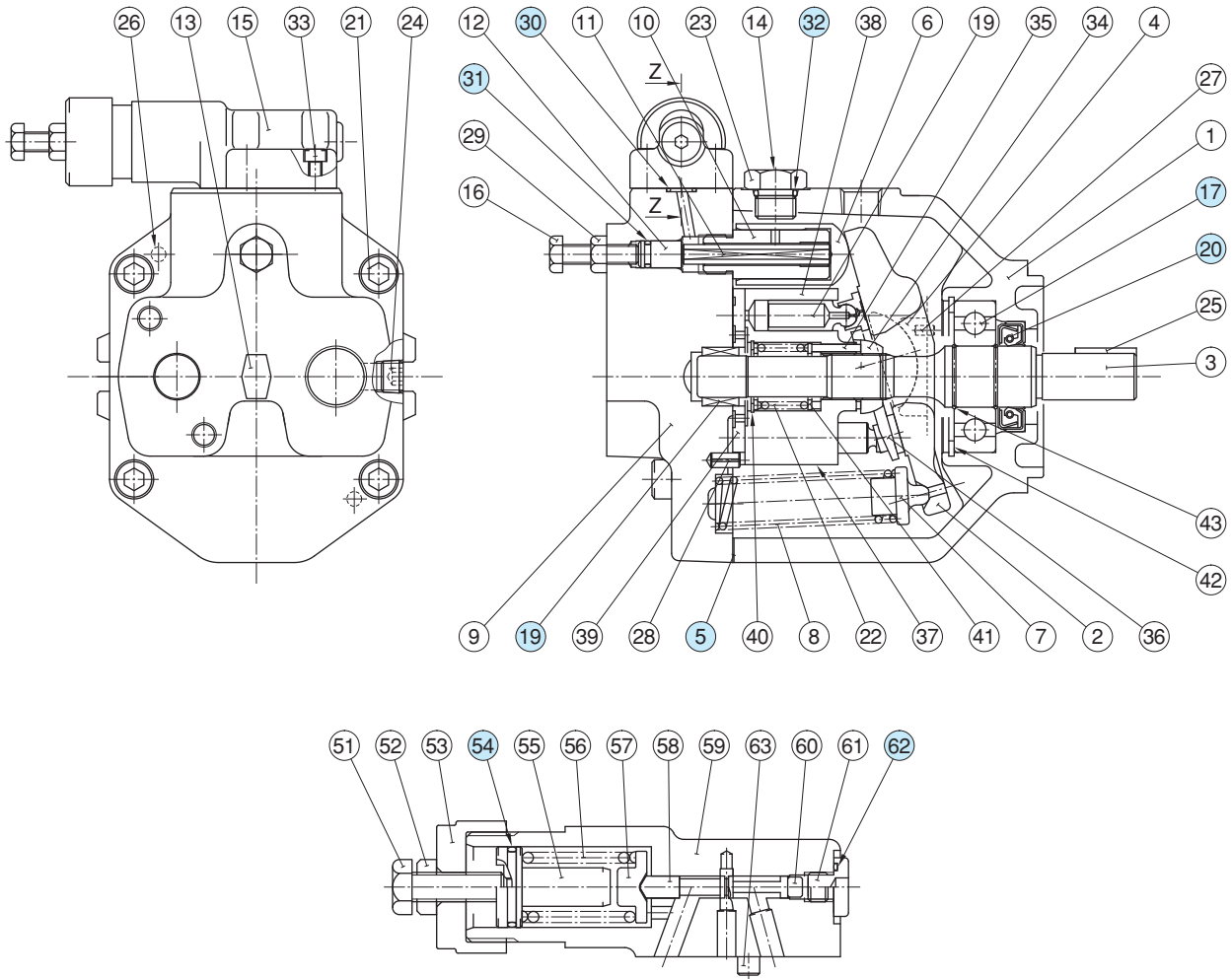

Section Z-Z

● List of Seals and Bearings

Item	Name of Part	Part Numbers		Qty.
		AR16-FR01	AR22-FR01	
5	Gasket	1302-PK314545-5		1
17	Bearing	6305		1
19	Bearing	HMK 1715 V2	Z30-1303-PK410300-8	1
20	Oil Seal	TCN 254511		1
30	O-Ring	OR NBR-90 P9-N		3
31	O-Ring	OR NBR-70-1 P8-N		1
32	O-Ring	OR NBR-90 P14-N		1
54	O-Ring	AS 568-018 (NBR-70-1)		1
62	O-Ring	OR NBR-90 P10-N		1

Series Variable Displacement Piston Pumps

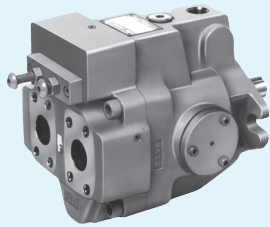

A37

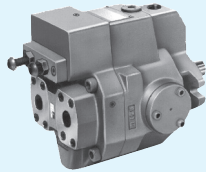

A16

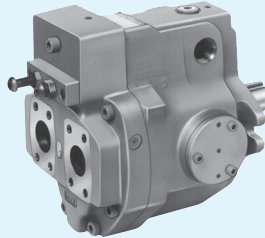

A56

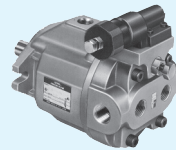

A10

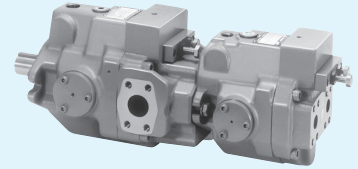

A1637

“A” Series Variable Displacement Piston Pumps

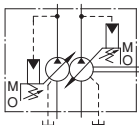
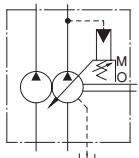
Pump Type	Graphic Symbol	Geometric Displacement cm ³ /rev							Maximum Operating Pressure MPa	Page			
		1	2	5	10	20	50	100			200	300	
Single Pumps ^{★1}		A10							21	A-25			
		A16							16				
		A22							21				
		A37							16				
		A45							21				
		A56							28				
		A70							21				
		A90							28				
Double Pumps		Outboard Pump	A16		A37	A56					28 ^{★2}	A-107	
		Inboard Pump	A16	A37	A56	A70	A145	A90					
		Outboard Pump	PV2R1		PV2R2								
		Inboard Pump	A16	A37	A56	A70	A145	A90					
Variable/Fixed Double Pumps		Outboard Pump	PV2R1		PV2R2						28 ^{★2}	A-109	
Inboard Pump	A16	A37	A56	A70	A145	A90							

^{★1} Various control types are available such as pressure compensator type. Refer to page A-26 and A-27.

^{★2} The maximum operating pressure for each double pump depends on its combination of pumps. Contact us for details.

Hydraulic Fluids

Hydraulic Fluids

Use petroleum based oils such as anti-wear type hydraulic oils equivalent to ISO VG-32 or 46. The recommended viscosity range is from 20 to 400 mm²/s and temperature range is from 0 to 60°C, both of which have to be satisfied for the use of the above hydraulic oils.

Control of Contamination

Due caution must be paid to maintaining control over contamination of the operating oil which can otherwise lead to breakdowns and shorten the life of the unit.

Please maintain the degree of contamination within NAS Grade 10.

The suction port must be equipped with at least a 100 μm (150 mesh) reservoir type filter and the return line must have a line type filter of under 10 μm.

Instructions

Mounting

When installing the pump the filling port should be positioned upwards.

Alignment of Shaft

Employ a flexible coupling whenever possible, and avoid any stress from bending or thrust.

Maximum permissible misalignment is less than 0.1 mm TIR and maximum permissible misangular is less than 0.2°.

Suction Pressure

Permissible suction pressure at inlet port of the pump is between -16.7 and +50 kPa.

For piping to the suction port, use the pipes of the same diameter as that of the specified pipe flange to be used. Make sure that the height of the pump suction port is within one meter from the oil level in the reservoir.

Hints on Piping

When using steel pipes for the suction or discharge ports, excessive load from the piping to the pump generates excessive noise.

Whenever there is fear of excessive load, please use rubber hoses.

Suction Piping

In case the pump is installed above the oil level, the suction piping and suction line filter should be located lower than the pump position to prevent air in the suction line.

When using steel pipes for the suction or discharge ports, excessive load from the piping to the pump generates excessive noise.

Whenever there is fear of excessive load, please use rubber hoses.

Drain Piping

Install drain piping according to the chart and ensure that pressure within the pump housing should be maintained at a normal pressure of less than 0.1 MPa and surge pressure of less than 0.5 MPa.

Length of piping should be less than 1 m, and the pipe end should be submerged in oil.

[Recommended Drain Piping Size]

Model	Fitting Size	Inside Dia. of Pipe
A10, A16, A22	3/8 [Inside Dia. 8.5 mm or more]	10 mm or more
A37, A45	1/2 [Inside Dia. 12 mm or more]	12 mm or more
A56, A70, A90, A100, A145	3/4 [Inside Dia. 16 mm or more]	19 mm or more

Bleeding Air

It may be necessary to bleed air from pump case and outlet line to remove causes of vibration. An air bleed valve (Model Number ST1004-*-10*, Page A-259) is recommended for this purpose.

Starting

Before first starting, fill pump case with clean operating oil via the filling port.

In order to avoid air blockage when first starting, adjust the control valves so that the discharged oil from the pump is returned direct to the reservoir or the actuator moves in a free load.

[Volume of Pre-fill Oil Required]

Model	Volume cm ³
A10	370
A16/A22	600
A37/A45/A56	1200
A70	2100
A90/A100	2500
A145	3300

Setting Discharge Pressure and Delivery

At the time of shipment, the unit has been preset to maximum delivery and minimum discharge pressure.

Adjust the preset delivery and pressure to meet your system requirements.

Adjustment of Discharge Pressure

Turning the adjustment screw clockwise, increases pressure.

[Volume adjusted by each full turn of the pressure adjustment screw]

Model Numbers	Adjustment Volume MPa
A10-FR01B	2.9
A10-FR01C/H	5.4
A16/A22/A37/A45/A56- *-R-01-B	3.5
A16/A22/A37/A45/A56- *-R-01-C	6.5
A16/A37/A56- *-R-01-H	7.9
A70/A90/A100/A145- *-R01B	2.3
A70/A90/A100/A145- *-R01C	3.2
A70/A90/A100/A145- *-R01H	4.0
A70/A90/A100/A145- *-R01K	4.7

Adjustment of Delivery

Turning the flow adjustment screw clockwise, decreases delivery.

[The minimum adjustable flow and adjustable volume of each full turn of the delivery adjustment screw]

Model	Adjustable volume with each full turn of the adjustment screw cm ³ /rev	Minimum Adjustable Flow cm ³ /rev
A10	1.1	2.0
A16	1.4	4.0
A22	2.0	6.0
A37/A45	2.9	10
A56	3.9	12
A70	4.4	36
A90	4.8	56
A100	5.2	62
A145	7.2	83

A Series Variable Displacement Piston Pumps

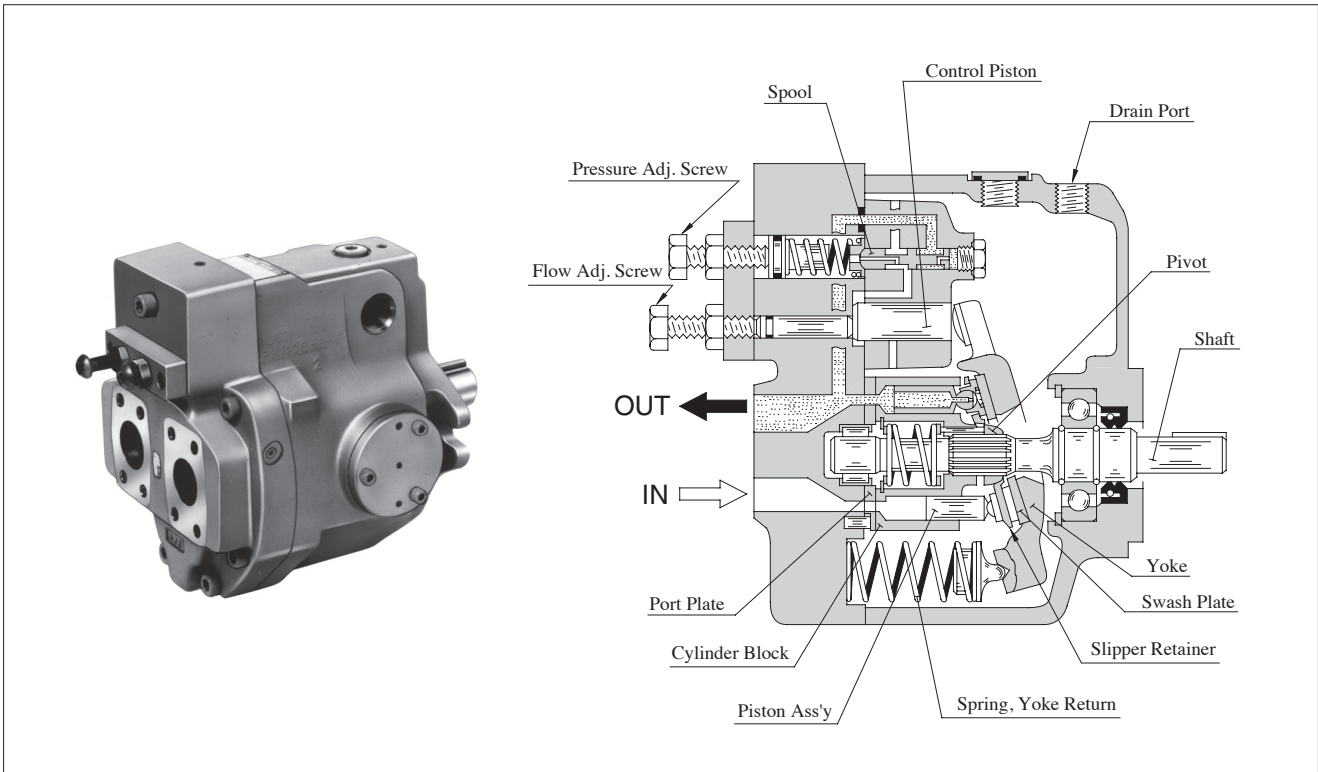

Features

High efficiency
The efficiency properties in case of “A16” pump are high efficiencies to be shown below.

Low noise level
In the “A16” pump, the noise level is as low as 57.3 dB(A) [at the full cut-off pressure 21 MPa with speed 1500 r/min one meter horizontally away from pump head cover.]

“A16” Type Performance Characteristics

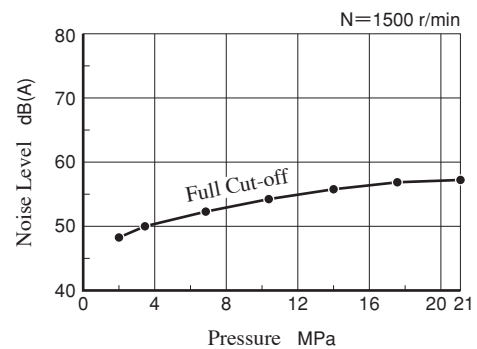
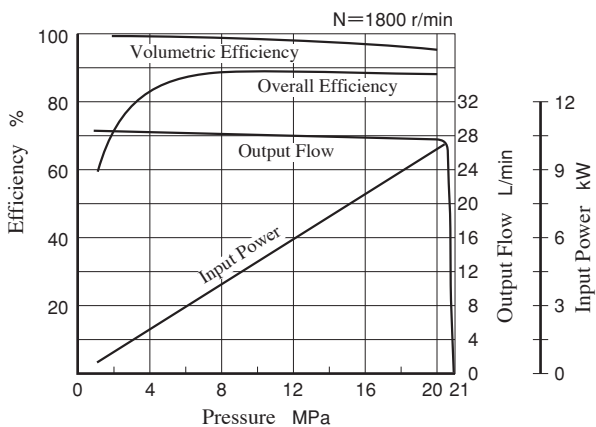

Accomplishment of energy-saving
Because the overall efficiency is high and the cut-off characteristics is sharp, thus the input power may be saved.

Low heat generation
Because of small power loss, it is possible to reduce the rise in oil temperature. Accordingly, capacity of a reservoir can be reduced.

Control Type

Control Type	Graphic Symbols	Performance Characteristics	Explanation	Page
"01" Pressure Compensator Type			When the system pressure increases and comes close to the preset cut-off pressure, the pump flow decreases automatically while maintaining the set pressure as it is.	A-28
"02" Solenoid Two Pressure Control Type			This type of control is ideal for an application where the output power of the actuator has to be controlled in two different load pressures while keeping the actuator speed nearly constant.	A-51
"03" Pressure Compensator with Unloading Type			It is suitable for a situation where a long unloading time is required and heat generation and noise have to be kept at their lowest levels. <ul style="list-style-type: none"> • The pump can be used in combination with the multistage pressure control valve. 	A-59
"04" Proportional Electro-Hydraulic Load Sensing Type			This is an energy-saving type control which regulates the pump flow and load pressure to be at absolute minimum necessary level to operate the actuator. Pump flow rate and cut-off pressure are controlled proportional to the input current to the control device on the pump and the input current is regulated by the specific amplifier.	A-60
"04E" Electro-Hydraulic Proportional Pressure & Flow Control Type			This type of control has the pressure sensor and tilt angle sensor in the pump. The pump is used with the external amplifier (amplifier is integrated into pump in case of "04EH").	A-70
"04EH" Electro-Hydraulic Proportional Pressure & Flow Control Type (OBE Type)			Flow and pressure can be controlled in proportion to input voltage by only one control valve. The features has been greatly improved by electrical feedback of swash plate tilt angle correspond to flow rate and load pressure to control valve. <ul style="list-style-type: none"> • Linearity of input characteristics is excellent and easy to set. • Hysteresis is lower, repeatability and reproducibility are fine. 	A-79
"05" Two-Pressure Two-Flow Control Type by System Pres.			This type of control is suitable for an application like "Presses" where the changeover from rapid advance to feed is required just when the pressing (pressurizing) starts.	A-88
"06" Two-Pressure Two-Flow Control Type by Solenoid Valve			This pump control is suitable for machining found on machine tool, where machining starts after the changeover from rapid advance to feed has been made.	A-89

Control Type

Control Type	Graphic Symbols	Performance Characteristics	Explanation	Page
"07" Pilot Pressure Control Type Pressure Compensator			The pump is used in combination with the pilot relief valve or multistage pressure control valve. By controlling the pilot pressure, the full cut-off pressure can be remote-controlled according to your requirements.	A-90
"09" Constant Power Control Type			<ul style="list-style-type: none"> • Pump input power can be controlled in accordance with the motor output. • When the discharge pressure rise, the output flow decreases corresponding to the preset input power. • The pump can act for function of two pumps, low-pressure large-flow and high-pressure small-flow. Therefore, the motor capacity can be reduced. 	A-98
"00-Z500" Simple Two-Pressure Two-Flow Control Type			<ul style="list-style-type: none"> • This type of control enables one pump to act as two pumps (low-pressure and large-flow/high-pressure and small-flow-rate). Therefore, the motor capacity can be reduced. • When the system pressure increases near the preset "PL" pressure due to the load increase, the pump flow automatically decreases to "QL." • This type of control is suitable for an application like the press, where switching from rapid advance to feed is required just when the press (pressurizing) starts. • The PH pressure can be remote-controlled with a separately located relief valve. With this type of control, it is easy to change the applied pressure setting when materials or shapes of the press are changed. 	A-106

Availability of Control Type

Mark "○" in the table below refers to standard model.

Model Numbers	Geometric Displacement cm ³ /rev	Control Type										
		01	02	03	04	04E	04EH	05	06	07	09	00-Z500
A10	10.0	○								○		
A16	15.8	○	○	○	○	○	○	○	○	○	○	○
A22	22.2	○	○	○	○	○	○		○	○		
A37	36.9	○	○	○	○	○	○	○	○	○	○	○
A45	45.0	○					○					
A56	56.2	○	○	○	○	○	○	○	○	○	○	○
A70	70.0	○	○	○	○	○	○		○	○	○	○
A90	91.0	○	○	○	○	○	○		○	○		○
A100	100	○			○	○						
A145	145	○	○	○	○	○	○		○	○	○	○

Series Variable Displacement Piston Pumps, Pressure Compensator Type

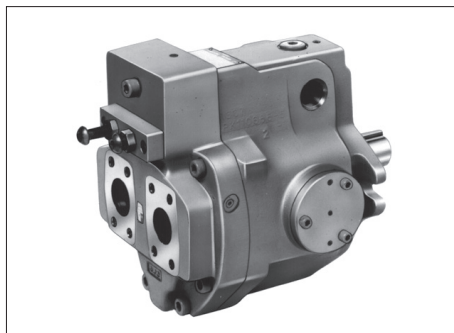

Graphic Symbol

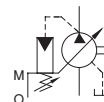

Specifications

Model Numbers	Geometric Displacement cm ³ /rev	Minimum Adj. Flow cm ³ /rev	Operating Pressure MPa		Shaft Speed Range r/min		Approx. Mass kg	
			Rated ^{★2}	Intermittent ^{★1}	Max.	Min.	Flange Mtg.	Foot Mtg.
A10-FR01 *-13	10.0	2	16	21	1800	600	8.5	—
A16- *-R-01- *- *-K-32	15.8	4	16	21	1800	600	16.5	18.7
A22- *-R-01- *- *-K-32	22.2	6	16	16	1800	600	16.5	18.7
A37- *-R-01- *- *-K-32	36.9	10	16	21	1800	600	Axial:23.2 Side:28	Axial:26.3 Side:31.1
A45- *-R-01- *- *-K-10	45.0	10	16	16	1800	600	28	32.3
A56- *-R-01- *- *-K-32	56.2	12	16	21	1800	600	Axial:30.8 Side:35	Axial:33.3 Side:38.1
A70- *R01 *S-70	70.0	36	25	28	1800	600	55.5	67.5
A90- *R01 *S-70	91.0	56	25	28	1800	600	72	87.5
A100- *R01 *S-20	100	62	21	21	1800	600	72.5	88
A145- *R01 *S-60	145	83	25	28	1800	600	92.5	117.7

- ★1. Whenever setting pressure, make sure the full cut-off pressure never exceeds the maximum intermittent pressure.
- ★2. Care should be taken in cases of used at a higher pressure than the rated pressure, because operating terms may be restricted. For example, if used as per maximum illustrated operating conditions, intermittent time at maximum flow is restricted to under 1/5 of one cycle time and under six seconds simultaneously. Conditions may vary according to the actual working pressure and delivery (inclination angle of the swash plate). Consult factory or Yuken sales representative for further information.
- ★3. The table above shows specifications for using petroleum based oils. Pumps (customized design) for special fluids are also available. Their operating pressure and maximum shaft speed however differ from the values in the table above depending on the fluid type. Range of operating temperature and viscosities may differ from those of petroleum based oils due to their characteristics. Refer to the table below for details.

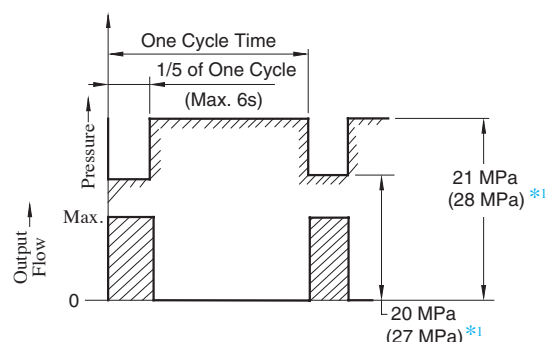

*1. Applicable only for "A70/90/145"

Specifications and Design numbers for Special Fluids

Type of Fluids	Pump Series	Operating Pressure MPa		Allowable Maximum Shaft Speed r/min		Temperature Range °C	Viscosity Range mm ² /s	Design Numbers for Special Fluid
		Rated	Intermittent	Rated	Max.			
Water-Glycols	A16,A22,A37,A56	14	16 (14) ^{★1}	1200	(1800) ^{★2}	0-50	20-200	3230
	A70,A90,A145	21	21					7030 [A70, A90] 6030 [A145]
	A100	16	16					2006
Phosphate Ester Type	A16,A22,A37,A56	14	16 (14) ^{★1}	1200	(1800) ^{★2}	0-60	20-200	3206
	A70,A90,A145	21	21					7006 [A70, A90] 6006 [A145]
	A100	21	21					2030
Polyol Ester Type	A16,A22,A37,A56	16	16	1800	1800	0-60	20-200	32450
	A70,A90,A145	21	21					70450 [A70, A90] 60450 [A145]
	A100	21	21					20450

- ★1. The figures in brackets are for A22 type.
- ★2. As the specific gravities of water-glycol fluids and phosphate ester type fluids are higher than one, an overhead reservoir is required when pumps are operated at 1400 r/min or more.

Model Number Designation

A16	-F	-R	-01	-B	-S	-K	-32
Series Number	Mounting	Direction of Rotation	Control Type	Pres. Adj. Range MPa	Port Position	Shaft Extension	Design Number
A16 (15.8 cm ³ /rev)	F: Flange Mtg. L: Foot Mtg.	(Viewed from Shaft End) R: Clockwise* ² (Normal)	01: Pressure Compensator Type	B: 1.2 - 7 C: 1.2 - 16 H: 1.2 - 21	None: Axial Port S: Side Port	K: Keyed Shaft	32
A22 (22.2 cm ³ /rev)				B: 1.2 - 7 C: 1.2 - 16			32
A37 (36.9 cm ³ /rev)				B: 1.2 - 7 * ³ C: 1.2 - 16 H: 1.2 - 21			32
A45 (45.0 cm ³ /rev)							10
A56 (56.2 cm ³ /rev)							32

A70	-F	R	01	B	S	-70
Series Number	Mounting	Direction of Rotation	Control Type	Pres. Adj. Range MPa	Port Position	Design Number
A10 (10.0 cm ³ /rev)	F: Flange* ¹ Mtg.	(Viewed from Shaft End) R: Clockwise* ² (Normal)	01: Pressure Compensator Type	B: 1.2 - 7 C: 2.0 - 16 H: 2.0 - 21	—	13
A70 (70.0 cm ³ /rev)	F: Flange Mtg. L: Foot Mtg.			B: 1.2 - 7 * ⁴ C: 1.5 - 16 H: 1.8 - 21 K: 2.0 - 28	S: Side Port	70
A90 (91.0 cm ³ /rev)						70
A100 (100 cm ³ /rev)						20
A145 (145 cm ³ /rev)						60

★ 1. When A10 pump is used as the foot Mtg., order the Mtg. bracket kit shown below separately. Refer to page A-17 for dimensions of the Mtg. bracket.

Note: The mounting bracket kit consists of a mounting bracket, two hex. bolts and two plain washer.

Mtg. Bracket Kit Numbers	Approx. Mass kg
LP-1A-10	2.2

★ 2. Available to supply pump with anti-clockwise rotation (except A100). Consult Yuken for details.

★ 3. Pres. adj. range of A45 type is B and C

★ 4. Pres. adj. range of A100 type is B, C, and H.

Pipe Flange Kits

Pipe flange kits are available. When ordering, specify the kit number from the table below.

Pump Model Numbers	Name of Port	Pipe Flange Kit Numbers		
		Threaded Connection	Socket Welding* ¹	Butt Welding
A16- * -R-01	Suction	F5-06-A-10	F5-06-B-10	F5-06-C-10
A22- * -R-01	Discharge	F5-06-A-10	F5-06-B-10	F5-06-C-10
A37- * -R-01	Suction	F5-10-A-10	F5-10-B-10	F5-10-C-10
A45- * -R-01	Discharge	F5-10-A-10	F5-10-B-10	F5-10-C-10
A56- * -R-01				
A70- * R01	Suction	F5-12-A-10	F5-12-B-10	F5-12-C-10
	Discharge	F5-08-A-10	F5-08-B-10	F5-08-C-10
A90- * R01	Suction	F5-16-A-10	F5-16-B-10	F5-16-C-10
A100- * R01	Discharge	F5-10-A-10	F5-10-B-10	F5-10-C-10
A145- * R01				

★ In case of using socket welding flanges, there is a case where the operating pressure should be set lower than the normal because of strength of the flanges. Therefore, please pay cautious attention to the operating pressure when the socket welding flanges are used.

● Details of the pipe flange kits are shown on pages A-258 and A-259.

Response Characteristics Change in Accordance with Circuits and Operating Conditions.

The Circuit and Conditions

Circuit

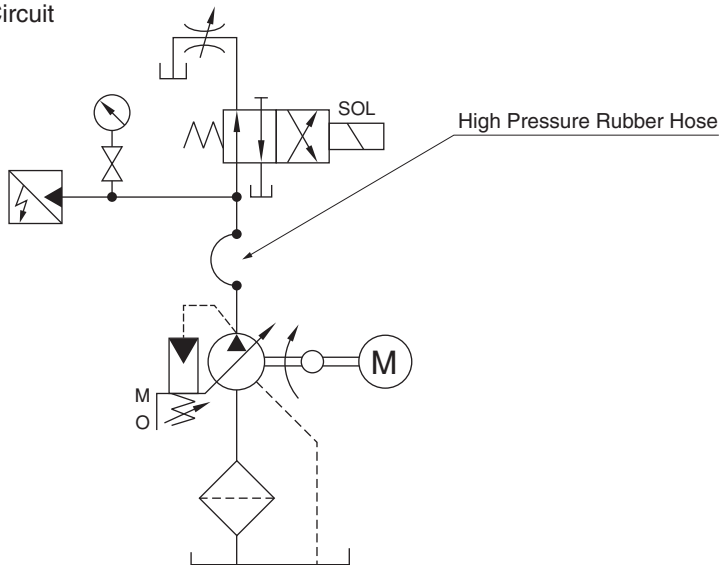

Model	Rubber Hose Size
A10	1/2"× 800 mm
A16 A22	3/4"× 700 mm
A37 A56	3/4"× 2000 mm
A70	3/4"× 3500 mm
A90 A100 A145	3/4"× 3000 mm + 1-1/4 × 2000 mm

Conditions

Shaft Speed : 1500 r/min
 Hydraulic Fluid : ISO VG 32 Oil
 Oil Temperature: See right table

Model	Oil Temperature
A10 - A56	50°C (20 mm ² /s)
A70 - A145	40°C (32 mm ² /s)

Result of Measurement

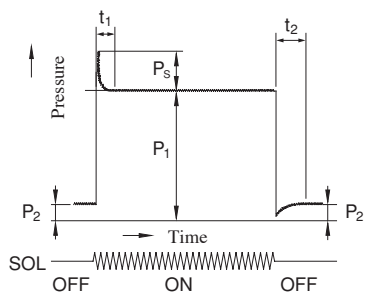

Model	Full Cut-off Pressure P ₁ MPa	Pressure at Full Flow P ₂ MPa	Response Time ms		Overshoot Pressure P _s MPa
			t ₁	t ₂	
A10	21	2	100	75	2.6
A16	16	2	38★	59★	3.6
A22	16	2	30★	72★	5.9
A37	16	2	40★	78★	7.8
A56	16	2	38★	88★	7.6
A70	25	2	80	100	7.8
A90	25	3	90	110	7.9
A100	21	3	90	110	8.1
A145	25	3	100	150	8.8

★ 1. Response time except A16, A22, A37 and A56 is measured Yoke travel.
 ★ 2. As for A45, please contact us.

Typical Performance Characteristics of Type **A10** at Viscosity 20 mm²/s [ISO VG32 Oils, 50°C]

Performance Characteristic Curve

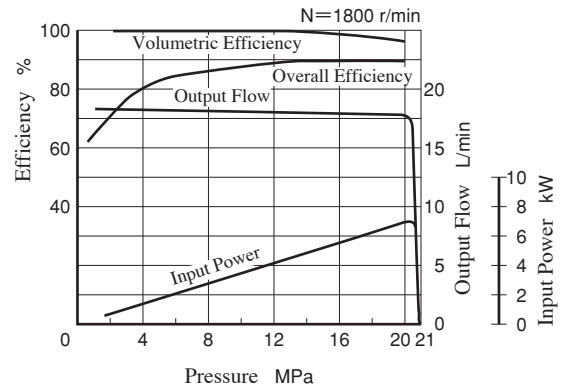
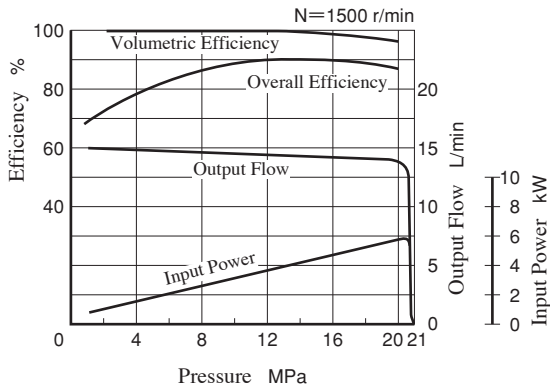

Input Power

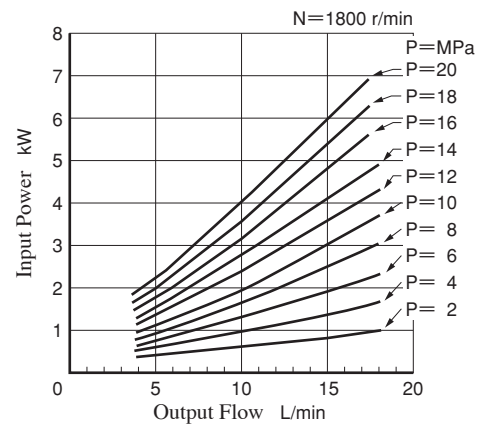
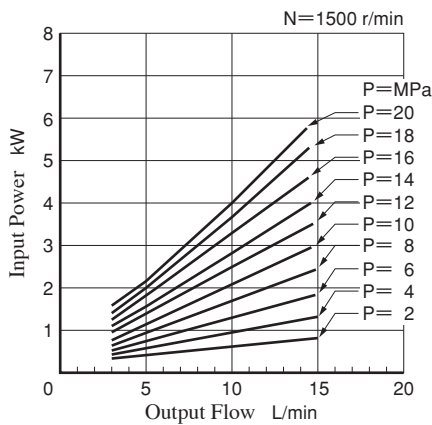

Full Cut-off Power

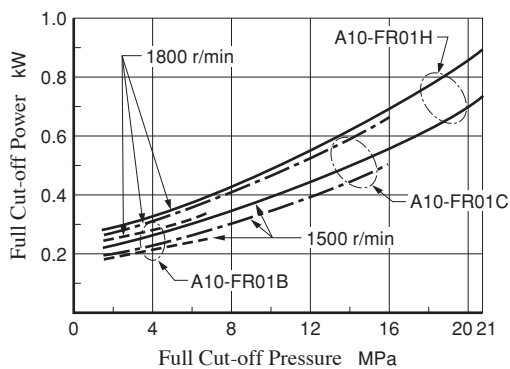

Drain

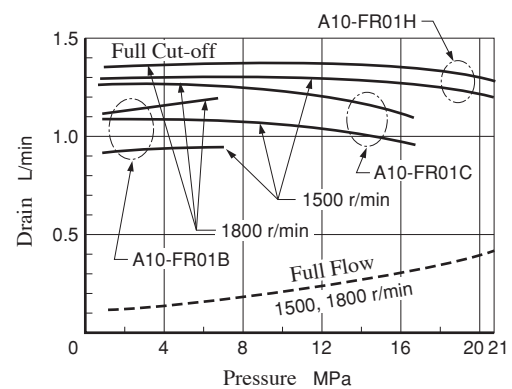

Noise Level [One meter horizontally away from pump head cover]

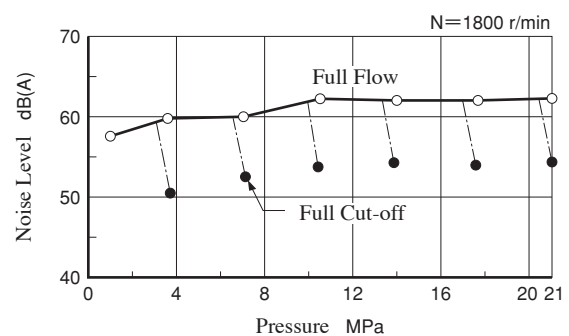
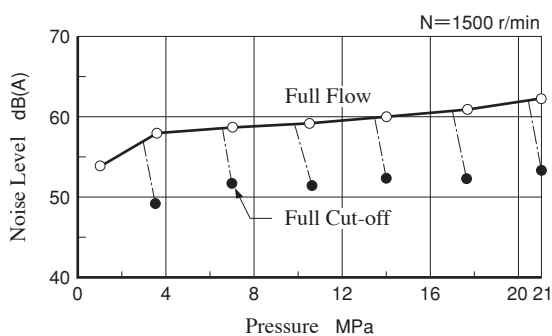

Typical Performance Characteristics of Type **A16** at Viscosity 20 mm²/s [ISO VG32 Oils, 50°C]

Performance Characteristic Curve

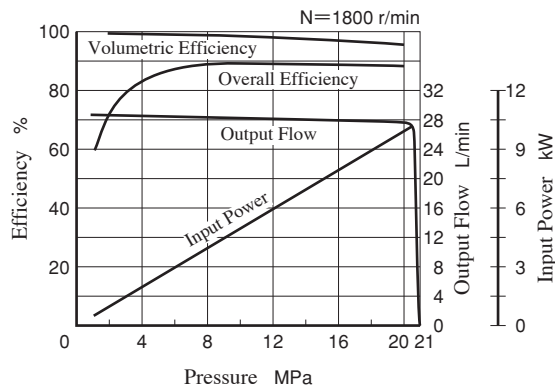
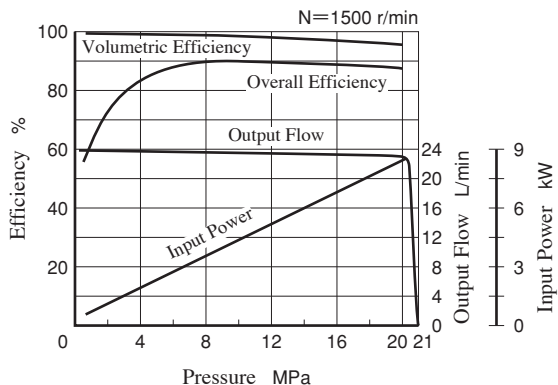

Input Power

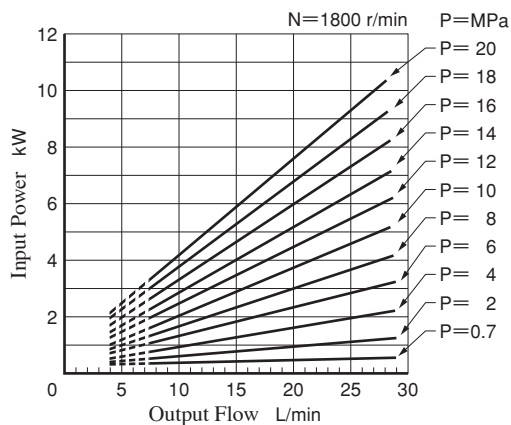
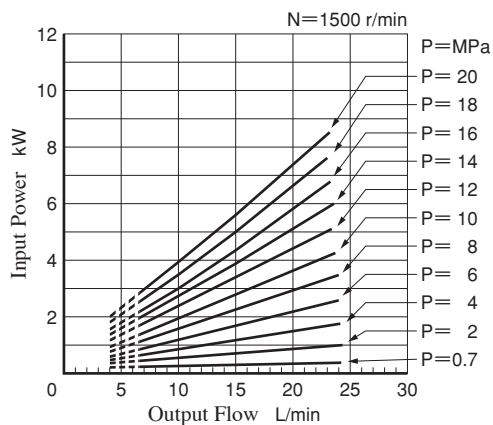

Full Cut-off Power

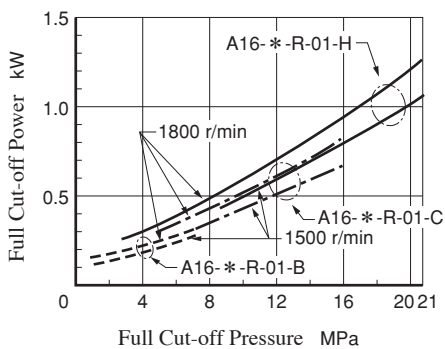

Drain

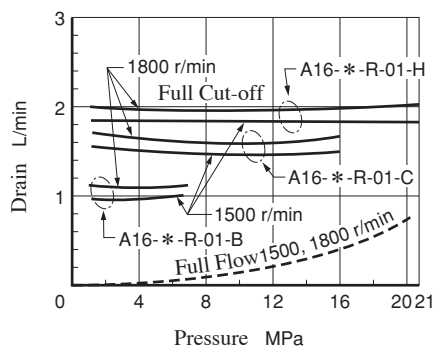

Noise Level [One meter horizontally away from pump head cover]

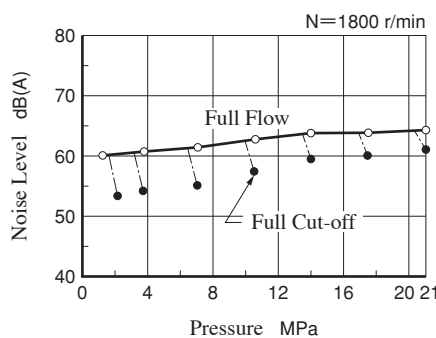
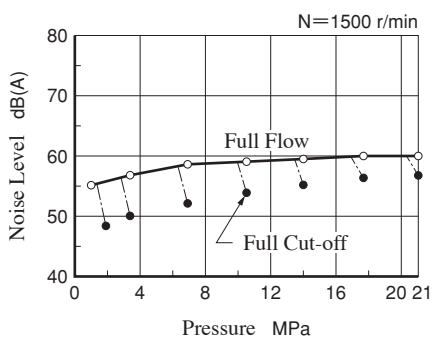

Typical Performance Characteristics of Type **A22** at Viscosity 20 mm²/s [ISO VG32 Oils, 50°C]

Performance Characteristic Curve

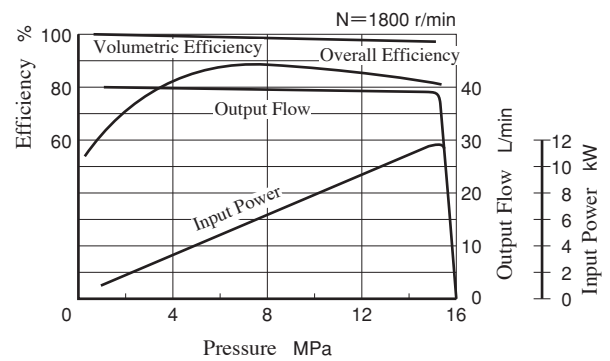
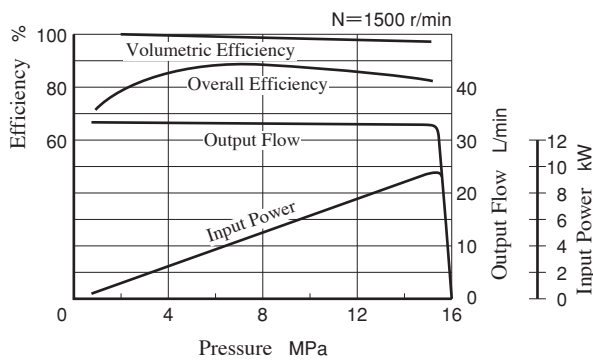

Input Power

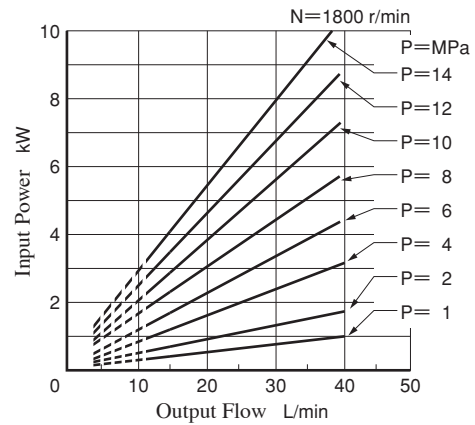
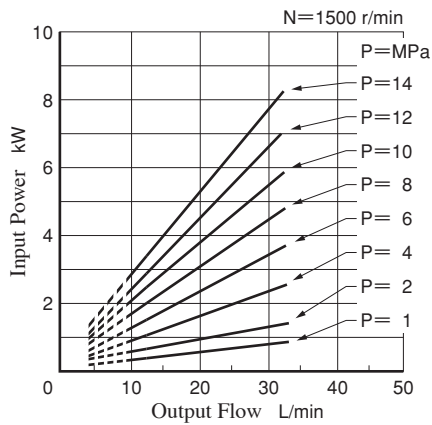

Full Cut-off Power

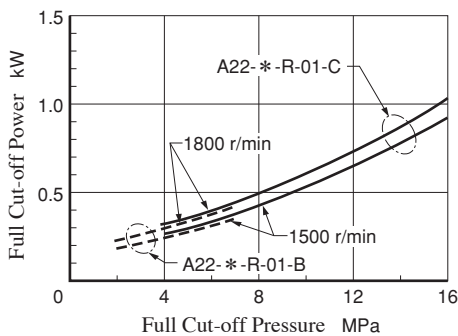

Drain

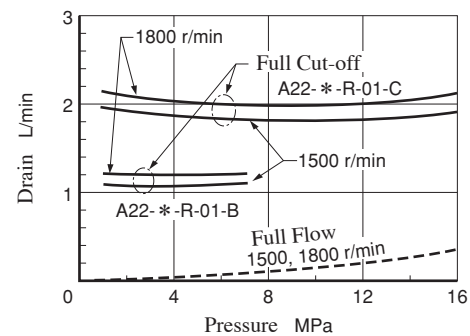

Noise Level [One meter horizontally away from pump head cover]

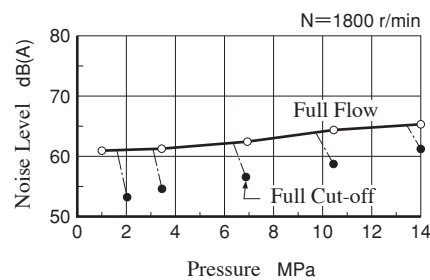
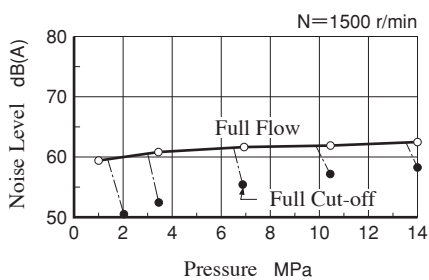

Typical Performance Characteristics of Type **A37** at Viscosity 20 mm²/s [ISO VG32 Oils, 50°C]

Performance Characteristic Curve

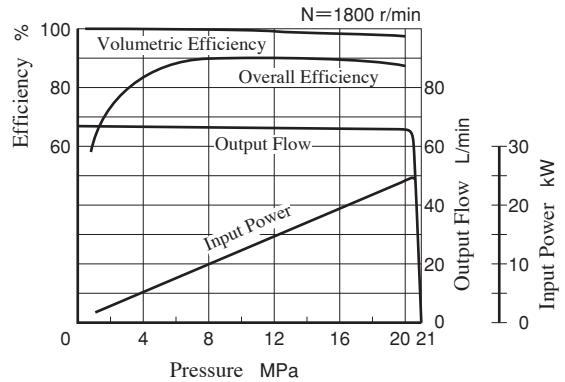
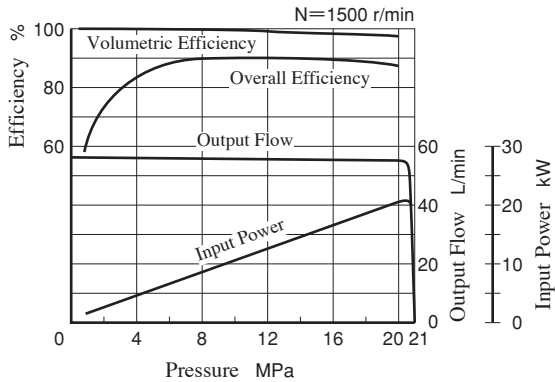

Input Power

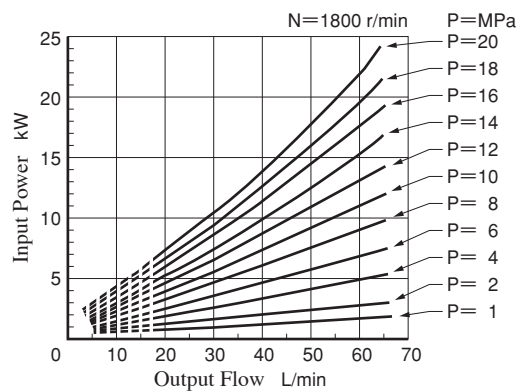
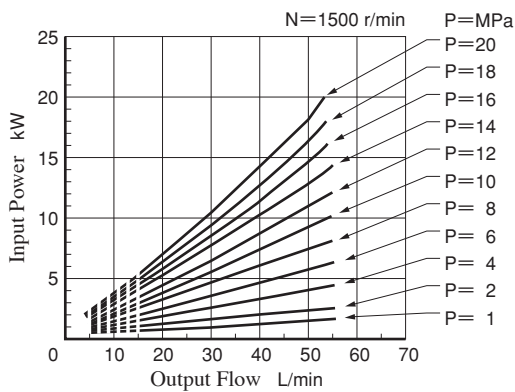

Full Cut-off Power

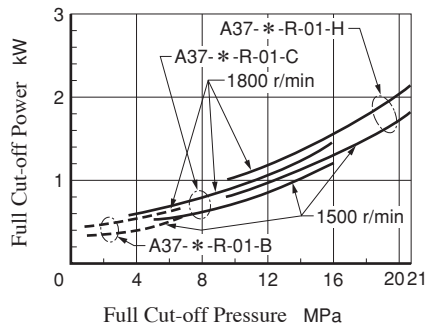

Drain

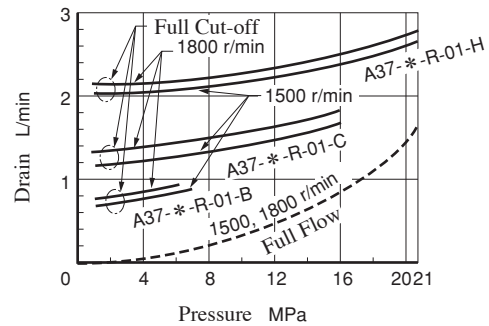

Noise Level [One meter horizontally away from pump head cover]

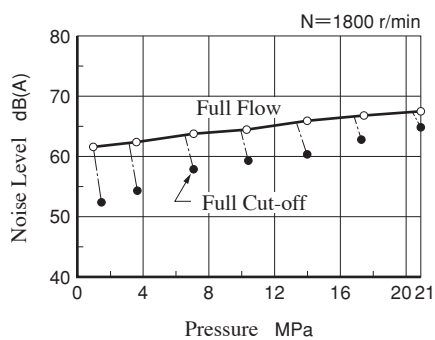
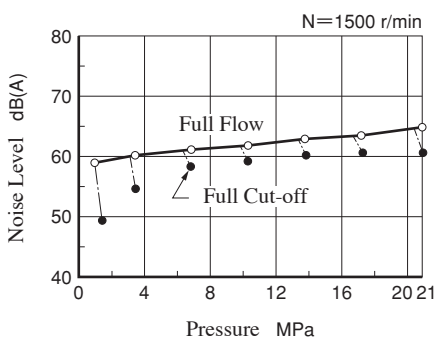

Typical Performance Characteristics of Type **A45** at Viscosity 32 mm²/s [ISO VG32 Oils, 40°C]

Performance Characteristic Curve

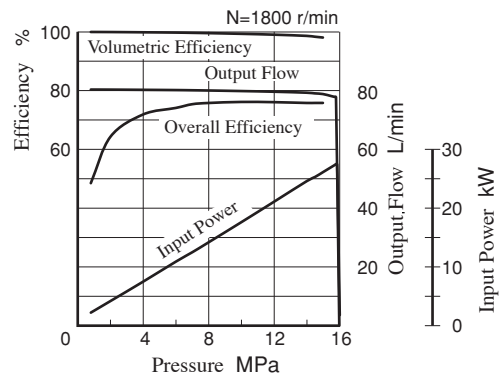
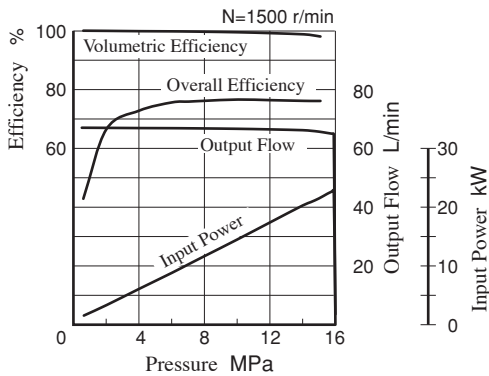

Input Power

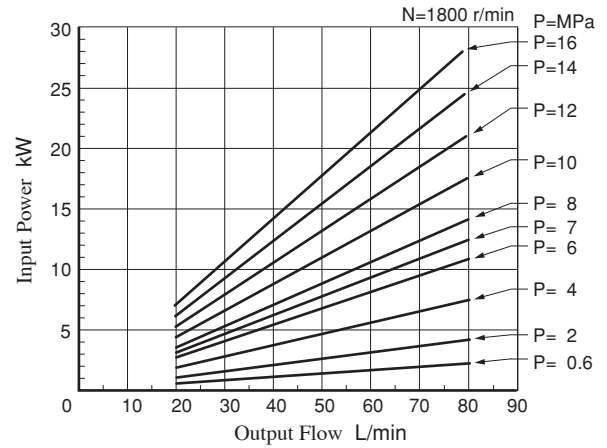
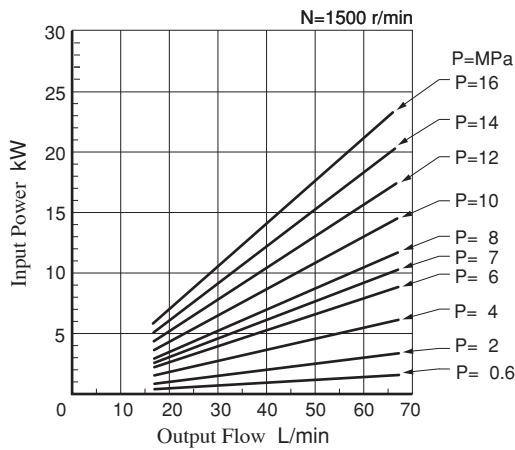

Full Cut-off Power

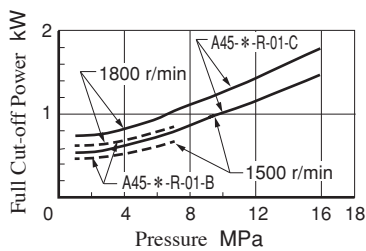

Drain

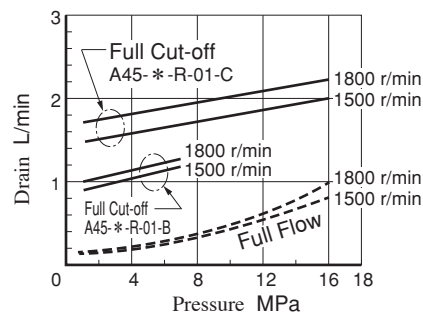

Noise Level [One meter horizontally away from pump head cover]

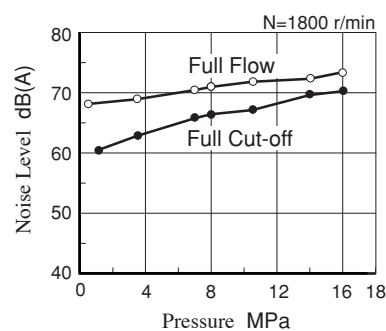
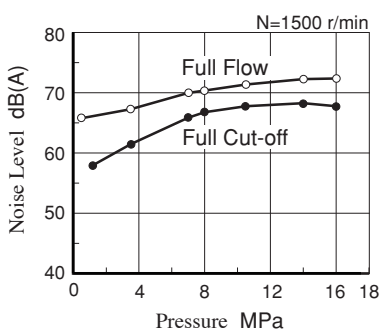

Typical Performance Characteristics of Type **A56** at Viscosity 20 mm²/s [ISO VG32 Oils, 50°C]

Performance Characteristic Curve

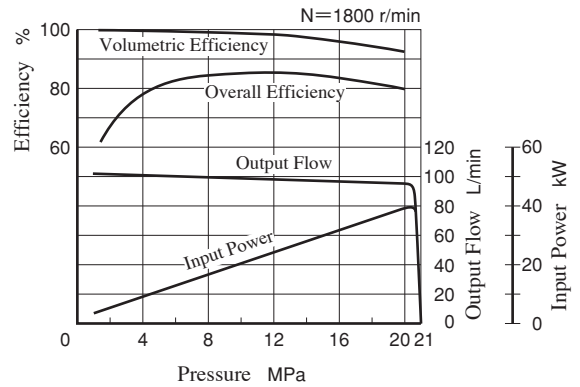
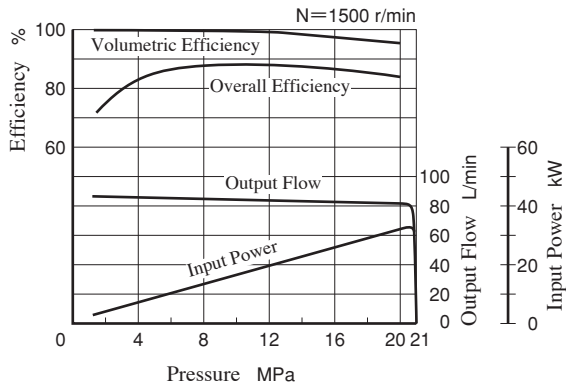

Input Power

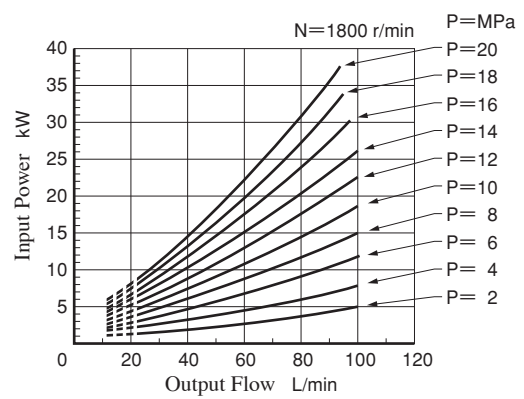
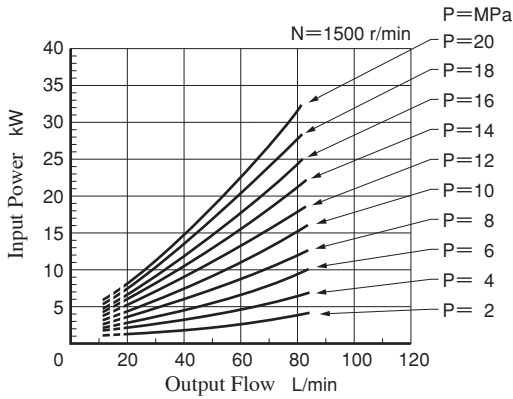

Full Cut-off Power

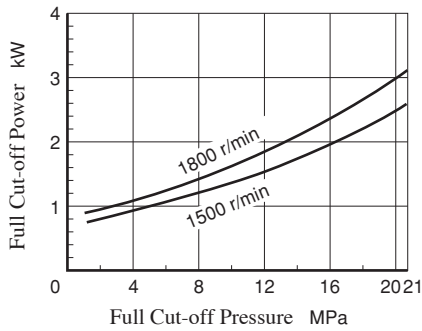

Drain

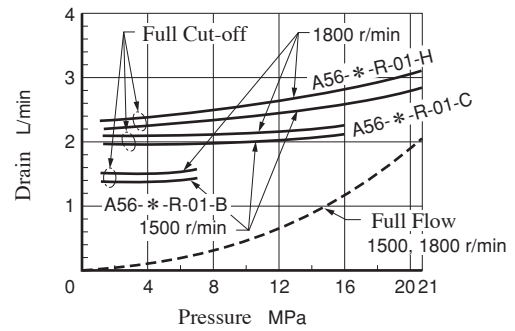

Noise Level [One meter horizontally away from pump head cover]

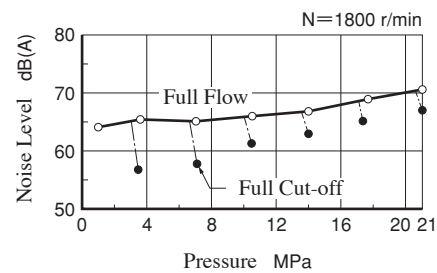
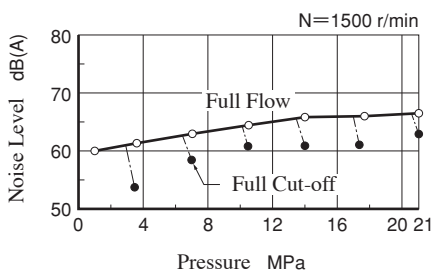

Typical Performance Characteristics of Type **A70** at Viscosity 20 mm²/s [ISO VG32 Oils, 50°C]

Performance Characteristic Curve

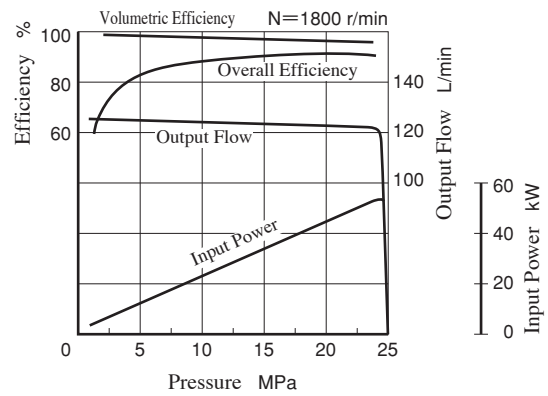
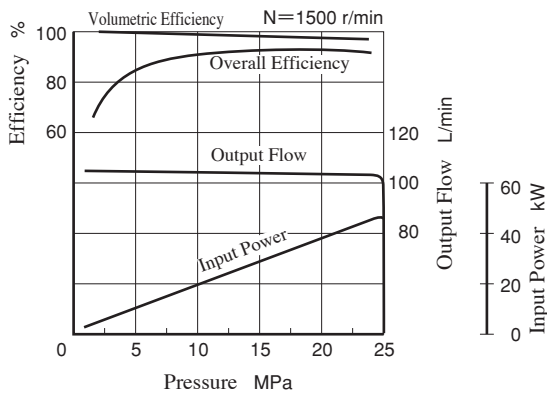

Input Power

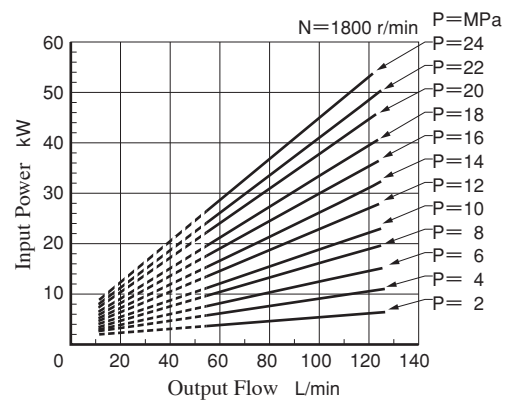
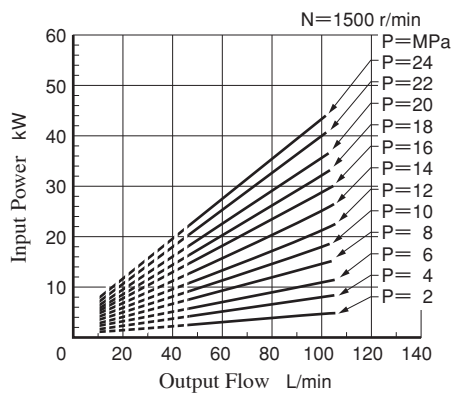

Full Cut-off Power

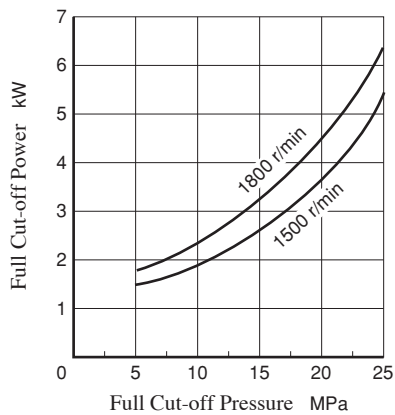

Drain

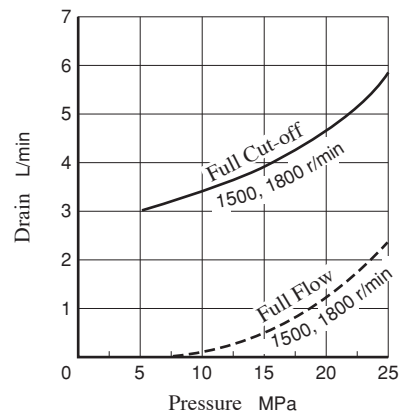

Noise Level [One meter horizontally away from pump head cover]

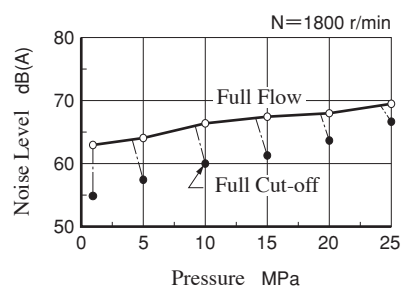
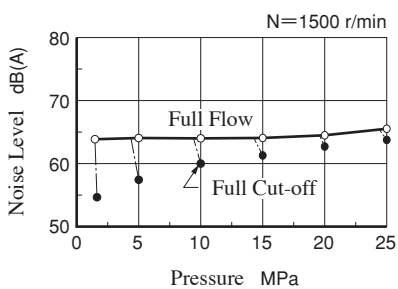

Typical Performance Characteristics of Type **A90** at Viscosity 20 mm²/s [ISO VG32 Oils, 50°C]

Performance Characteristic Curve

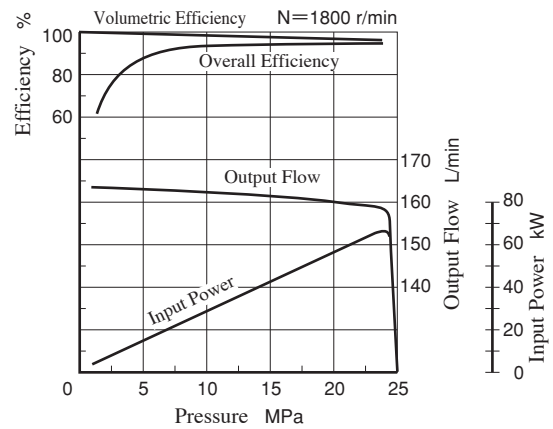
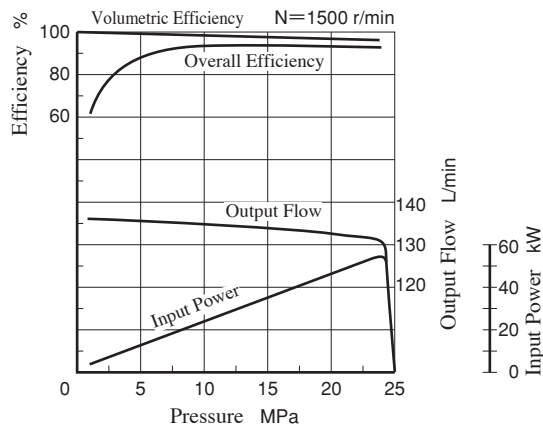

Input Power

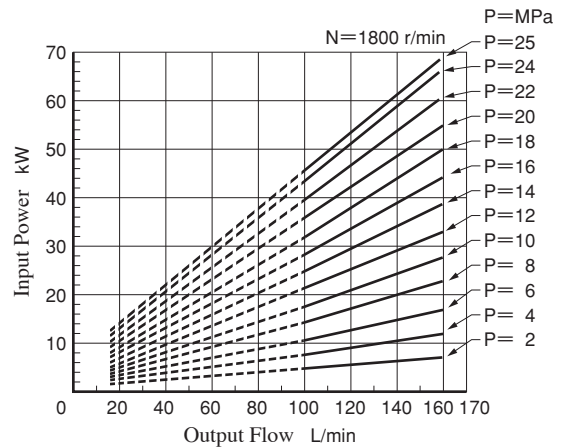
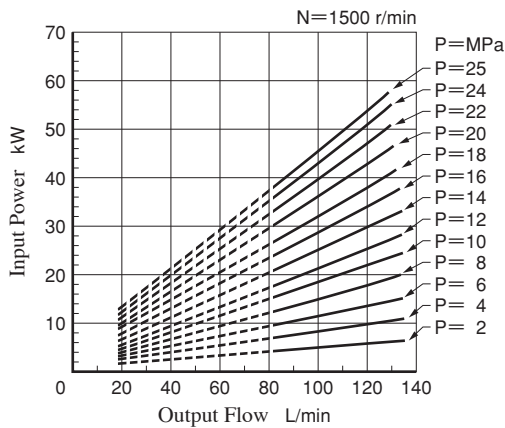

Full Cut-off Power

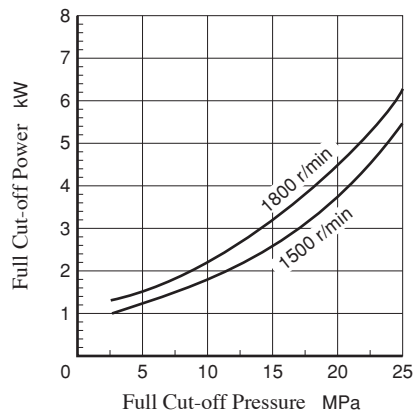

Drain

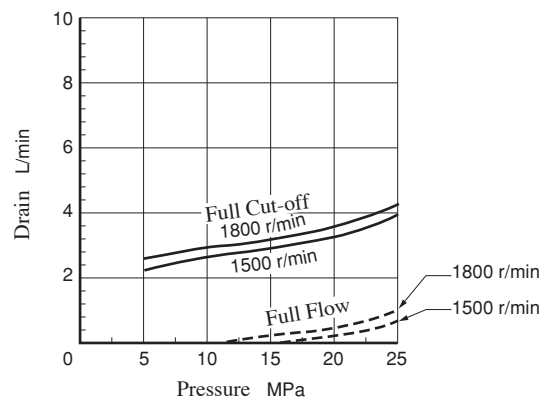

Noise Level [One meter horizontally away from pump head cover]

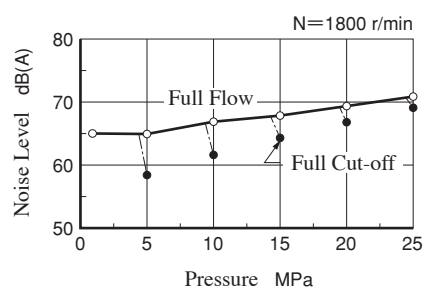
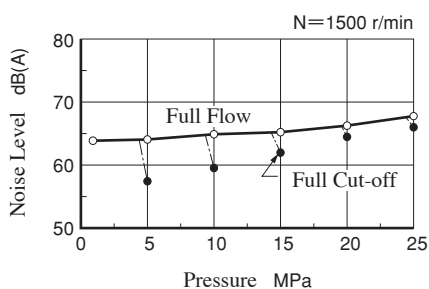

Typical Performance Characteristics of Type A100 at Viscosity 20 mm²/s [ISO VG32 Oils, 50°C]

Performance Characteristic Curve

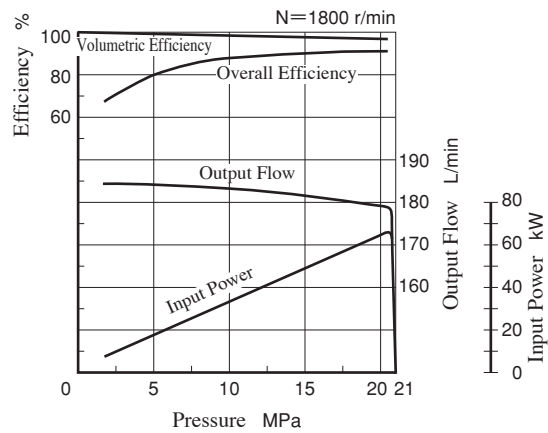
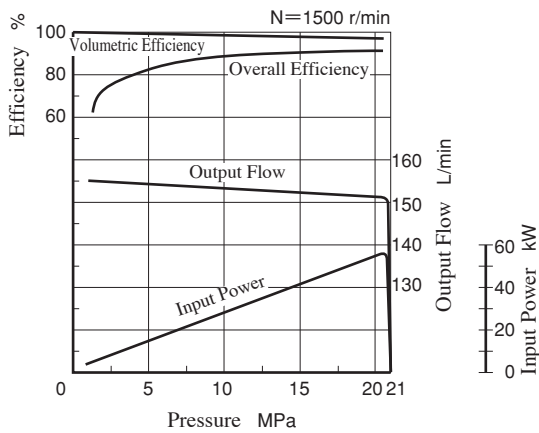

Input Power

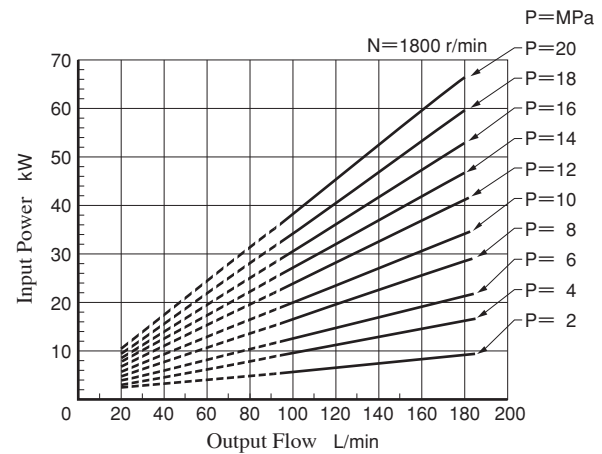
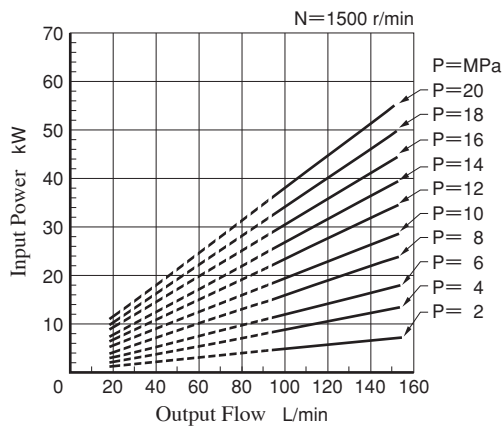

Full Cut-off Power

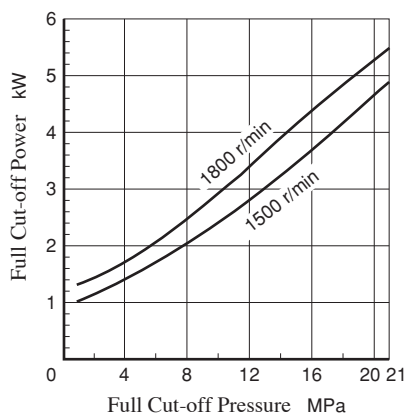

Drain

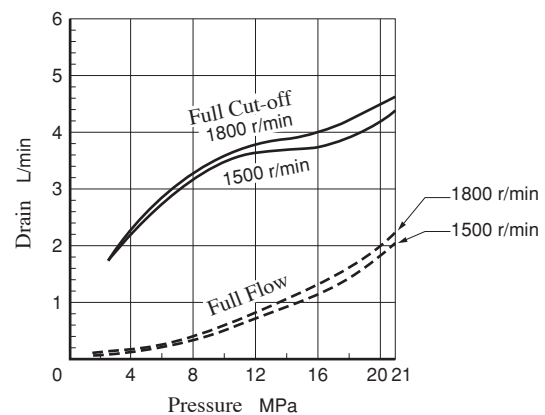

Noise Level [One meter horizontally away from pump head cover]

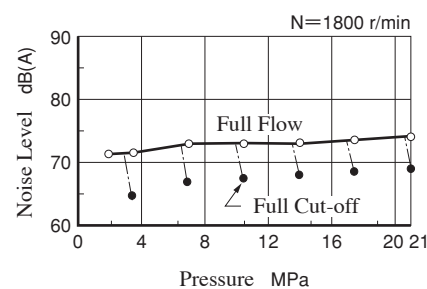
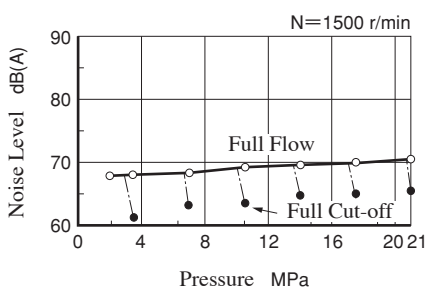

Typical Performance Characteristics of Type **A145** at Viscosity 20 mm²/s [ISO VG32 Oils, 50°C]

Performance Characteristic Curve

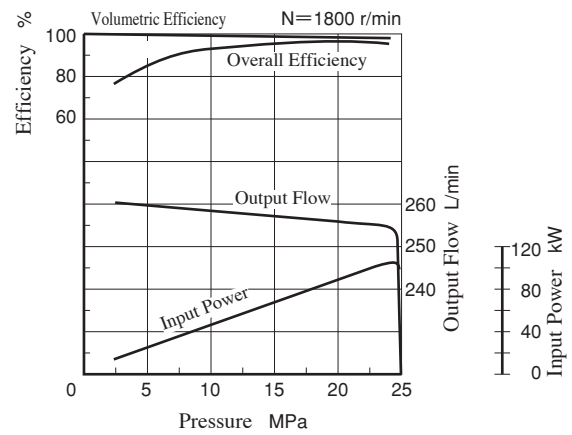
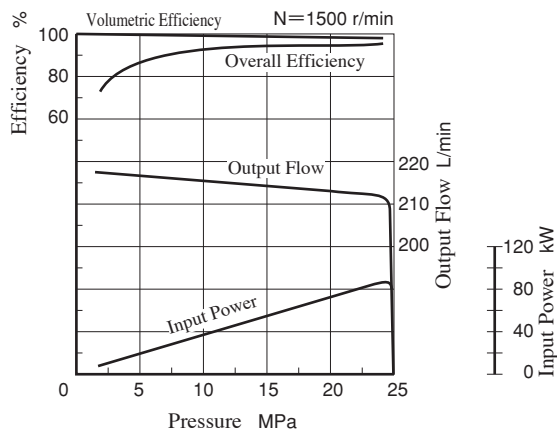

Input Power

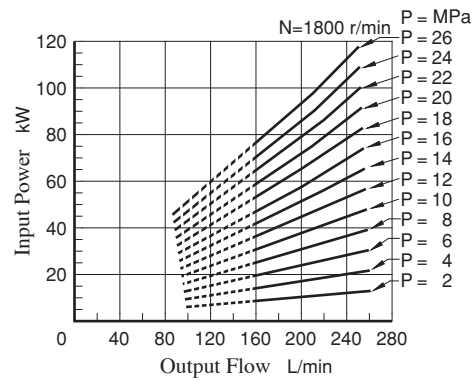
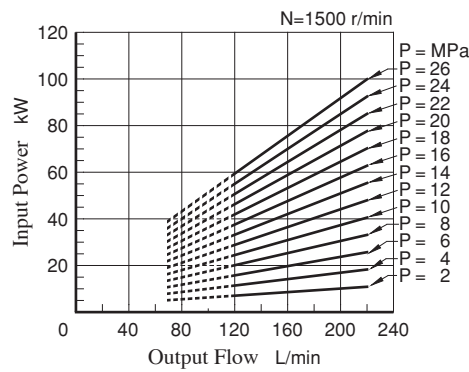

Full Cut-off Power

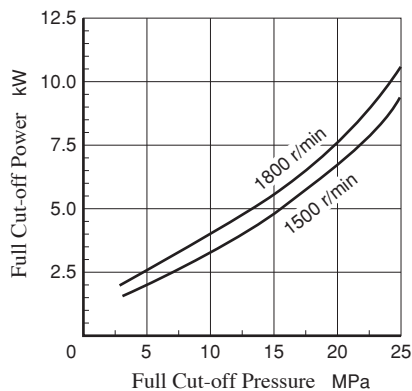

Drain

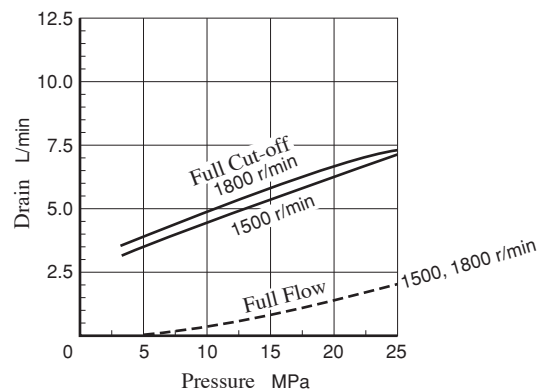

Noise Level [One meter horizontally away from pump head cover]

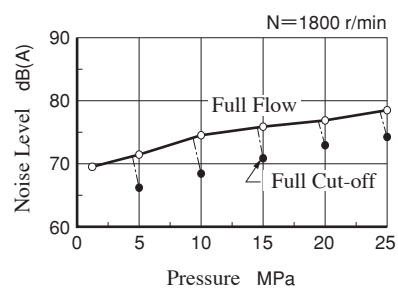
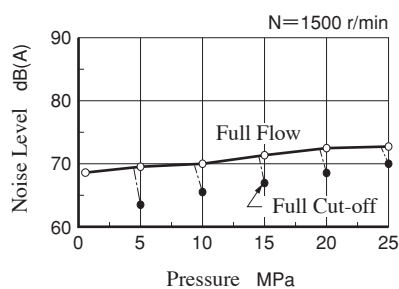

Flange Mtg. : A10-FR01 *

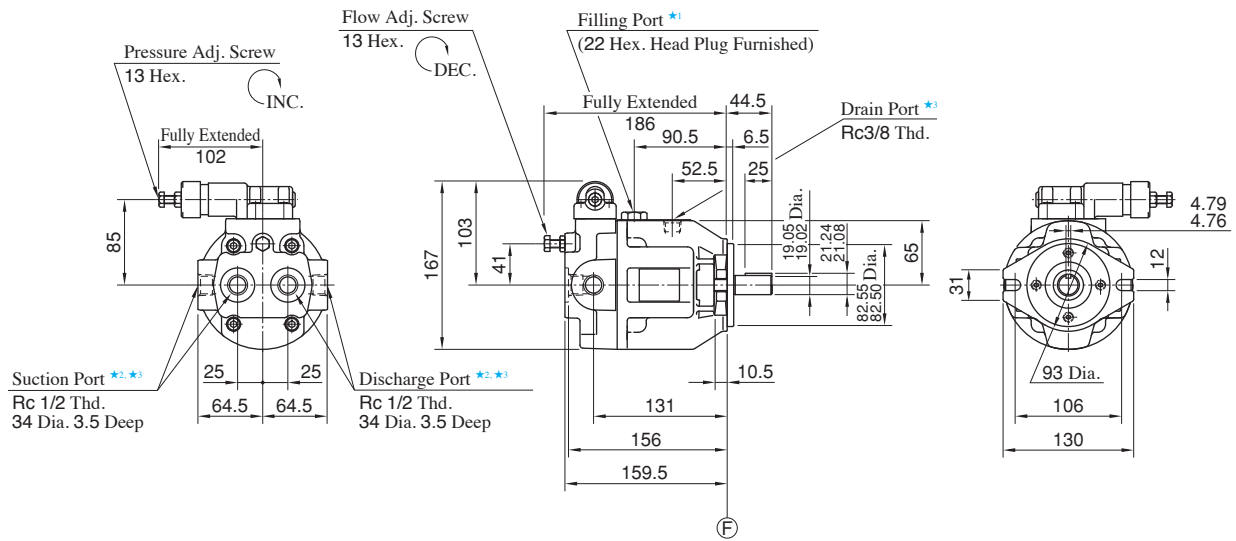

- ★1. Install the pump so that the "Filling Port" is at the top.
- ★2. Use either port of two suction and discharge ports at your option. Keep the remaining ports plugged.
- ★3. As the tightening torques of suction, discharge and drain port fittings, conform to the below.

Name of Port	Tightening Torque Nm
Suction	65 - 75
Discharge	
Drain	40 - 50

Axial Port Type

**Flange Mtg. : A16-F-R-01- *-K
A22-F-R-01- *-K**

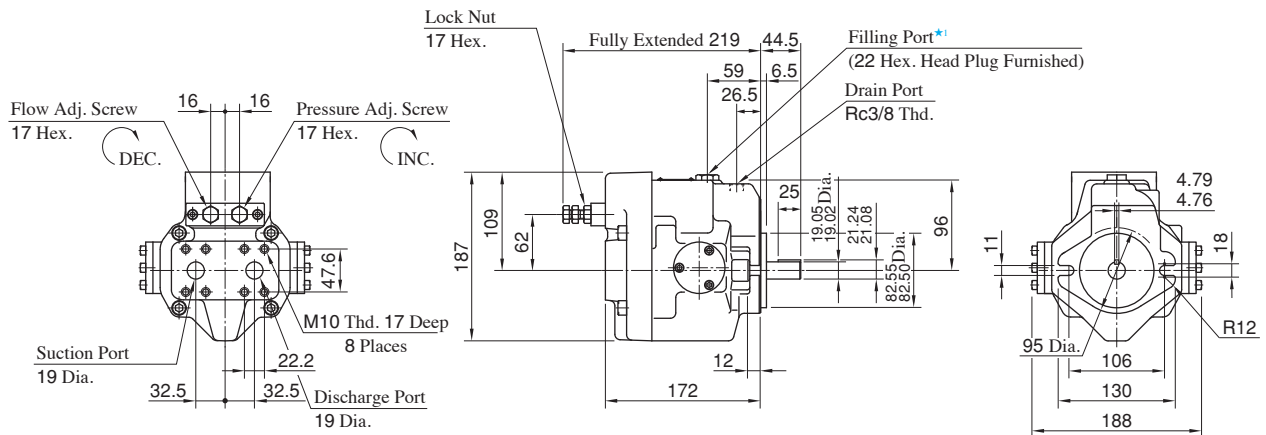

★ 1. Install the pump so that the “Filling Port” is at the top.

**Foot Mtg. : A16-L-R-01- *-K
A22-L-R-01- *-K**

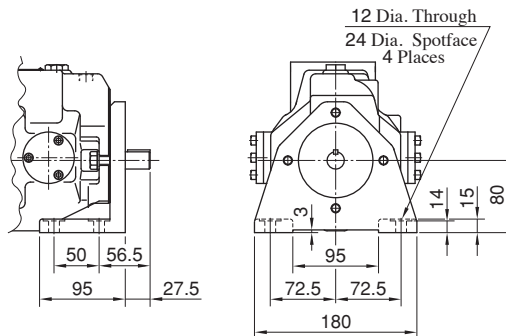

● For other dimensions, refer to “Flange Mtg.”.

Side Port Type

**Flange Mtg. : A16-F-R-01- *-S-K
A22-F-R-01- *-S-K**

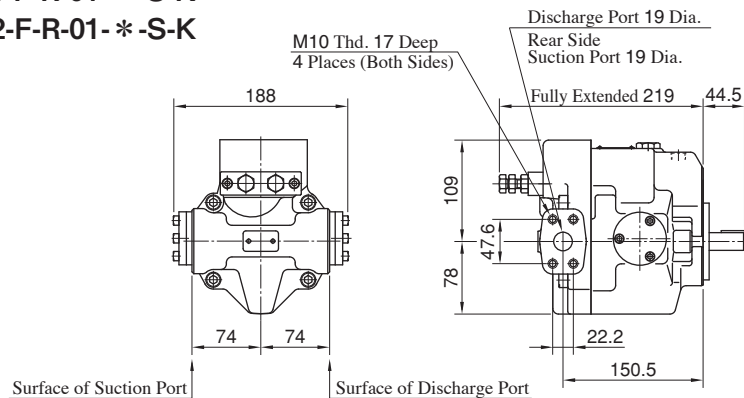

● For other dimensions, refer to “Axial Port Type”.

● Foot Mtg. Type : Mounting bracket is common to that of “Axial Port Type”.

Axial Port Type

**Flange Mtg. : A37-F-R-01- *-K
A45-F-R-01- *-K**

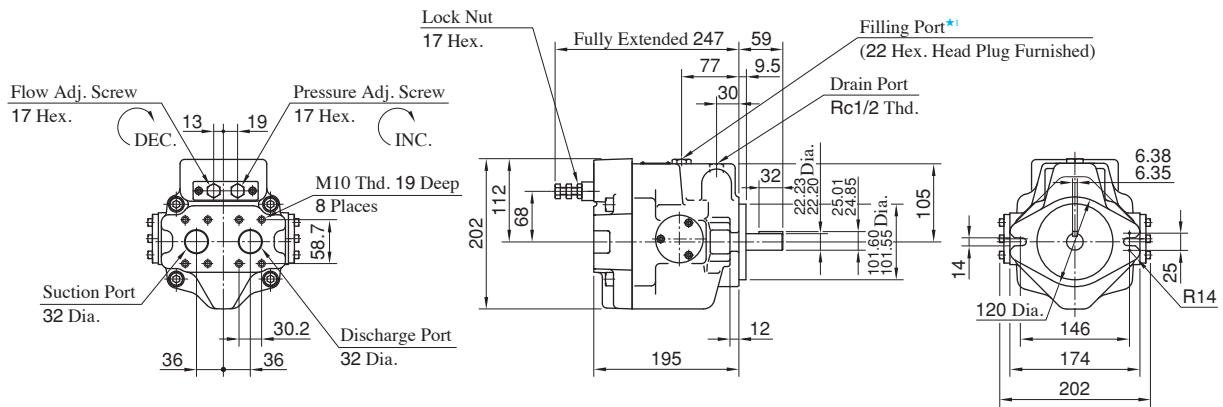

★ 1. Install the pump so that the “Filling Port” is at the top.

**Foot Mtg. : A37-L-R-01- *-K
A45-L-R-01- *-K**

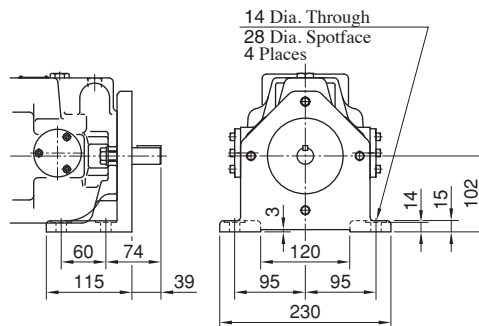

● For other dimensions, refer to “Flange Mtg.”.

Side Port Type

**Flange Mtg. : A37-F-R-01- *-S-K
A45-F-R-01- *-S-K**

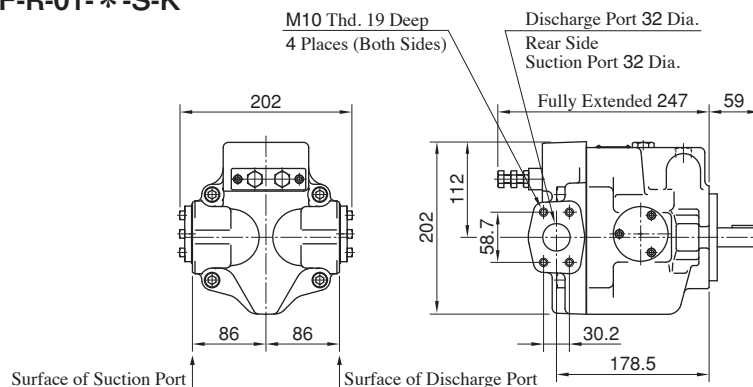

● For other dimensions, refer to “Axial Port Type”.

● Foot Mtg. Type : Mounting bracket is common to that of “Axial Port Type”.

Axial Port Type

Flange Mtg. : A56-F-R-01- *-K

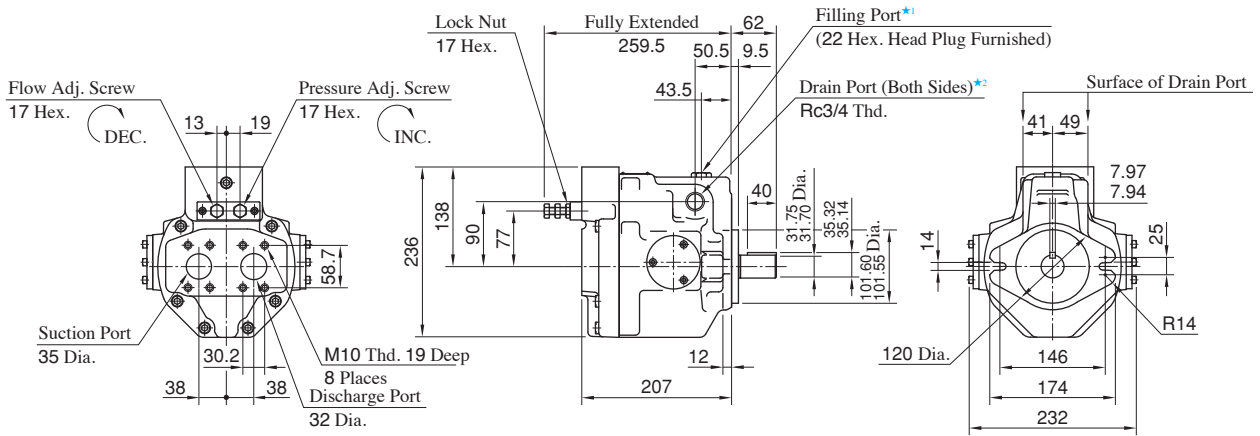

- ★ 1. Install the pump so that the “Filling Port” is at the top.
- ★ 2. Use either port of the two drain ports at your option. Keep the remaining port plugged.

Foot Mtg. : A56-L-R-01- *-K

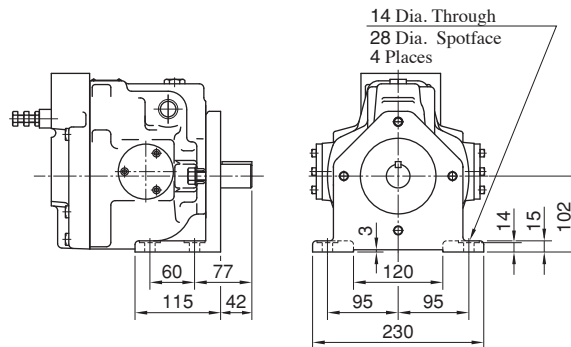

● For other dimensions, refer to “Flange Mtg.”.

Side Port Type

Flange Mtg. : A56-F-R-01- *-S-K

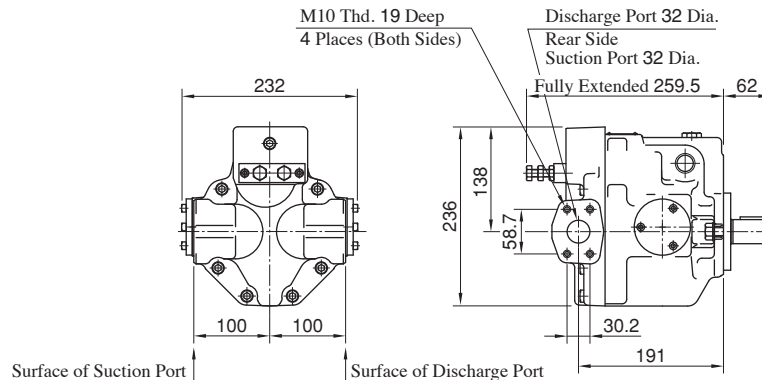

● For other dimensions, refer to “Axial Port Type”.

Side Port Type

Flange Mtg. : A70-FR01 * S

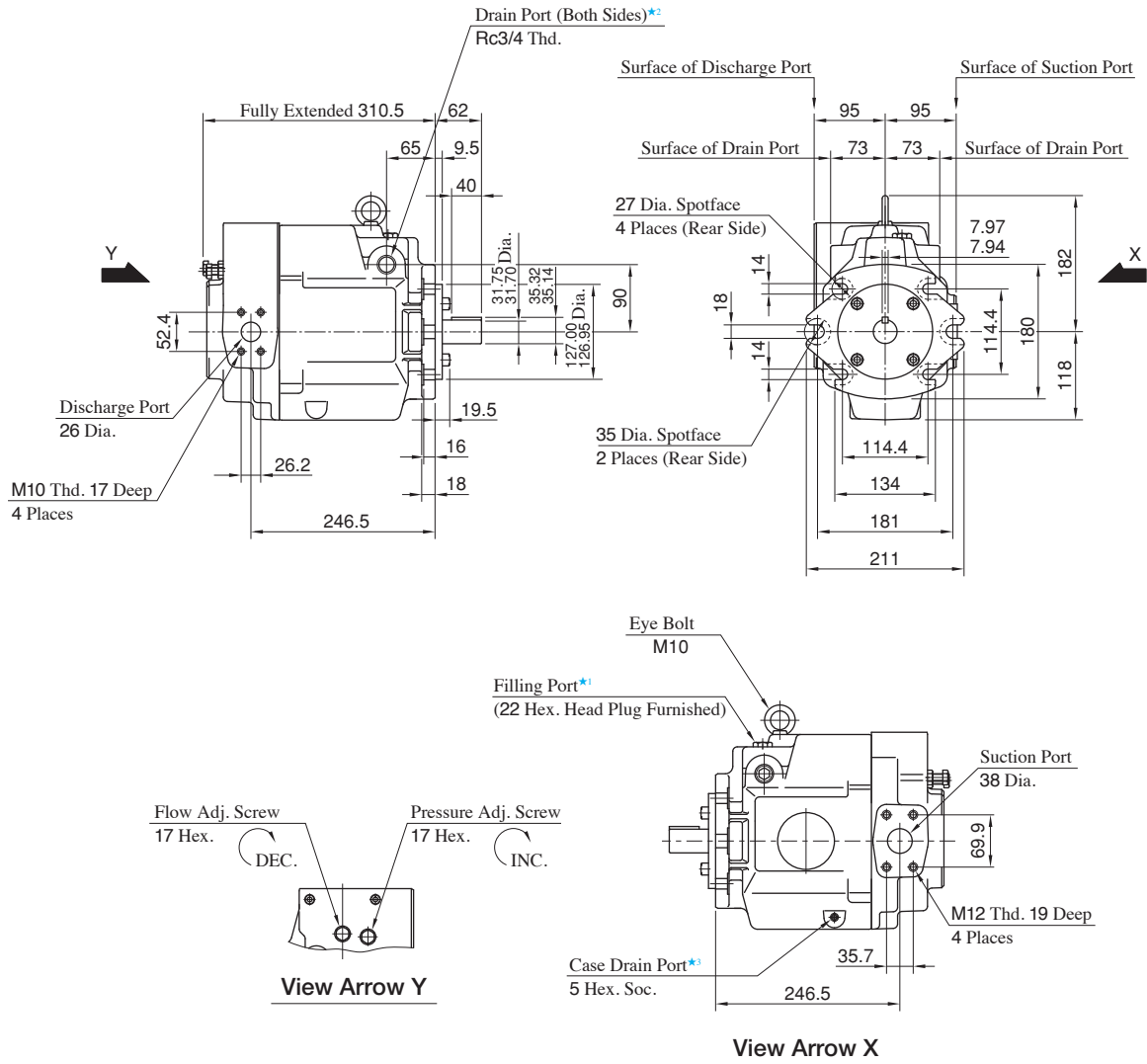

- ★1. Install the pump so that the “Filling Port” is at the top.
- ★2. Use either port of the two drain ports at your option. Keep the remaining port plugged.
- ★3. Case drain port is available for use when draining hydraulic fluid from pump casing.

Foot Mtg. : A70-LR01 * S

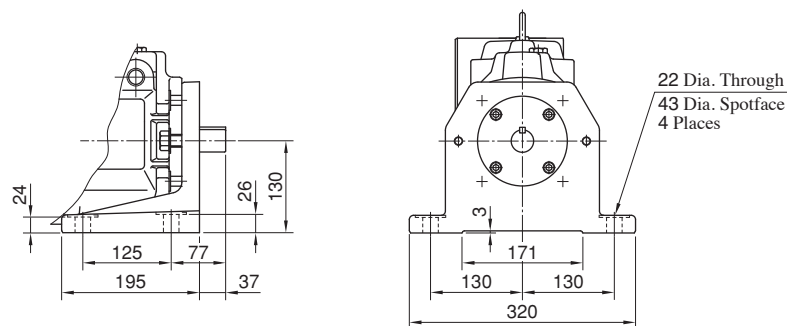

● For other dimensions, refer to “Flange Mtg.”.

Side Port Type

**Flange Mtg. : A90-FR01 * S
A100-FR01 * S**

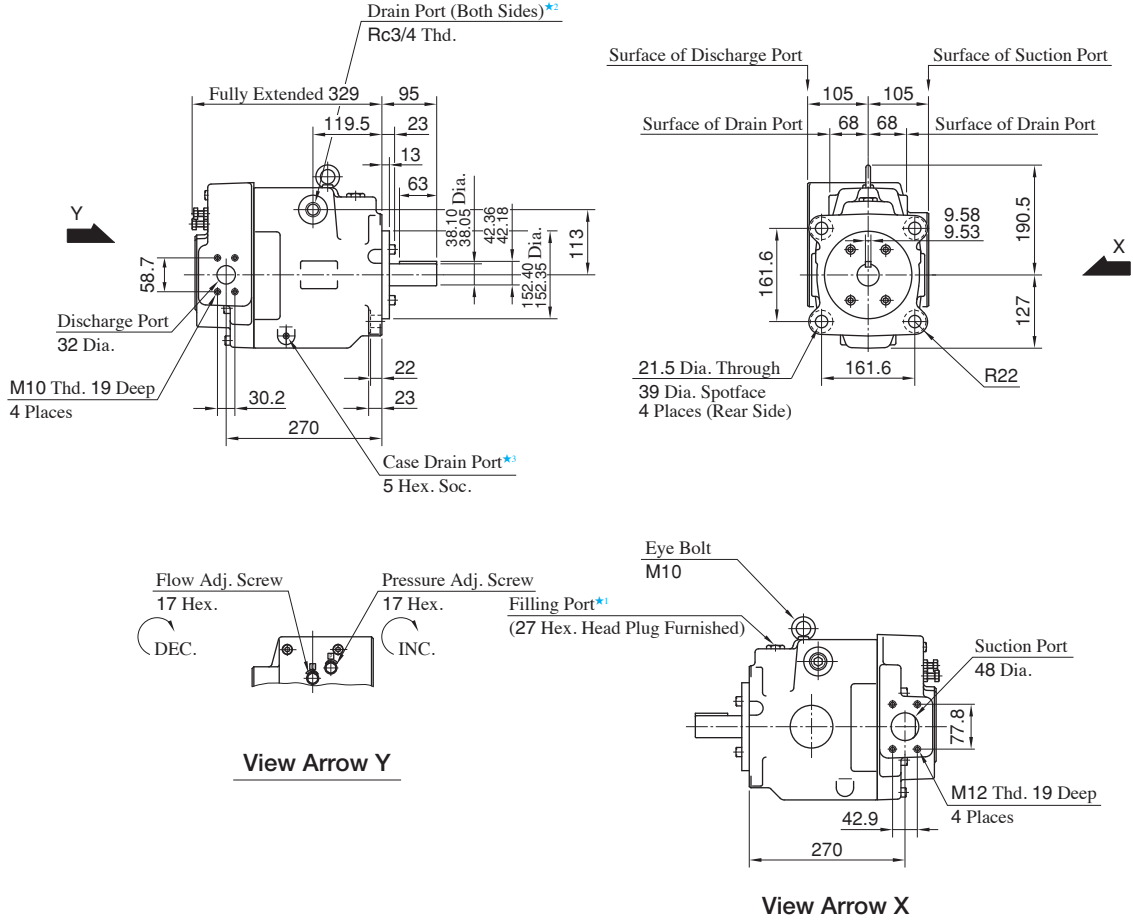

- ★1. Install the pump so that the “Filling Port” is at the top.
- ★2. Use either port of the two drain ports at your option. Keep the remaining port plugged.
- ★3. Case drain port is available for use when draining hydraulic fluid from pump casing.

**Foot Mtg. : A90-LR01 * S
A100-LR01 * S**

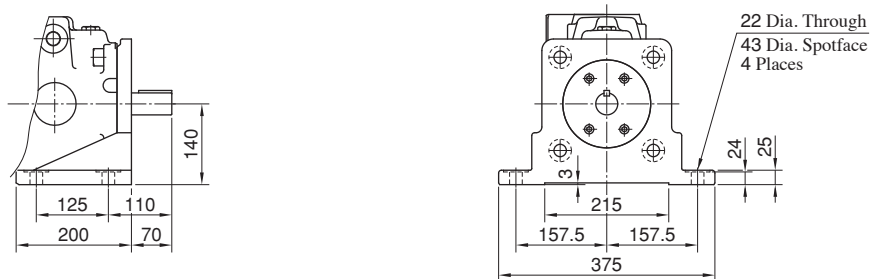

● For other dimensions, refer to “Flange Mtg.”.

Side Port Type

Flange Mtg. : A145-FR01 * S

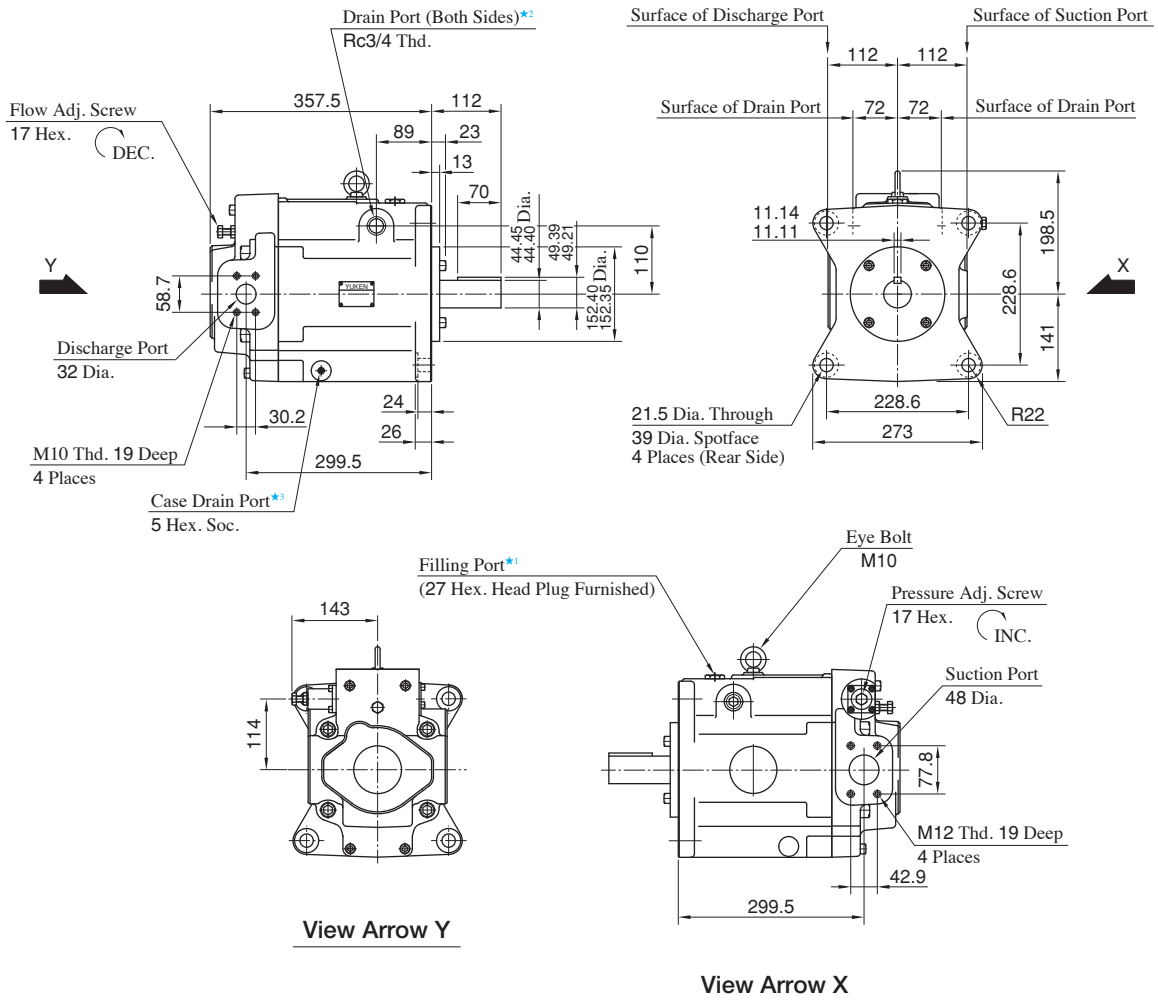

- ★1. Install the pump so that the “Filling Port” is at the top.
- ★2. Use either port of the two drain ports at your option. Keep the remaining port plugged.
- ★3. Case drain port is available for use when draining hydraulic fluid from pump casing.

Foot Mtg. : A145-LR01 * S

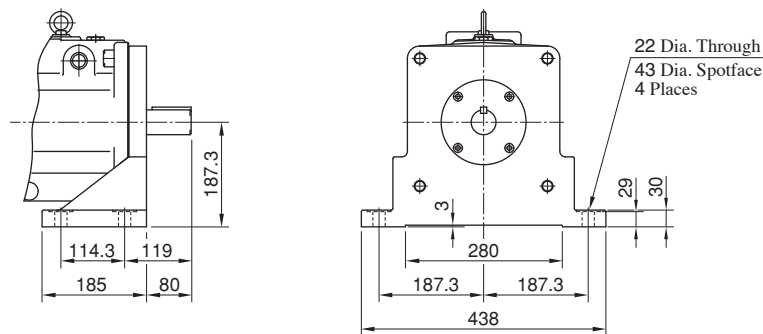

● For other dimensions, refer to “Flange Mtg.”.

Spare Parts List

A10-F-R-01

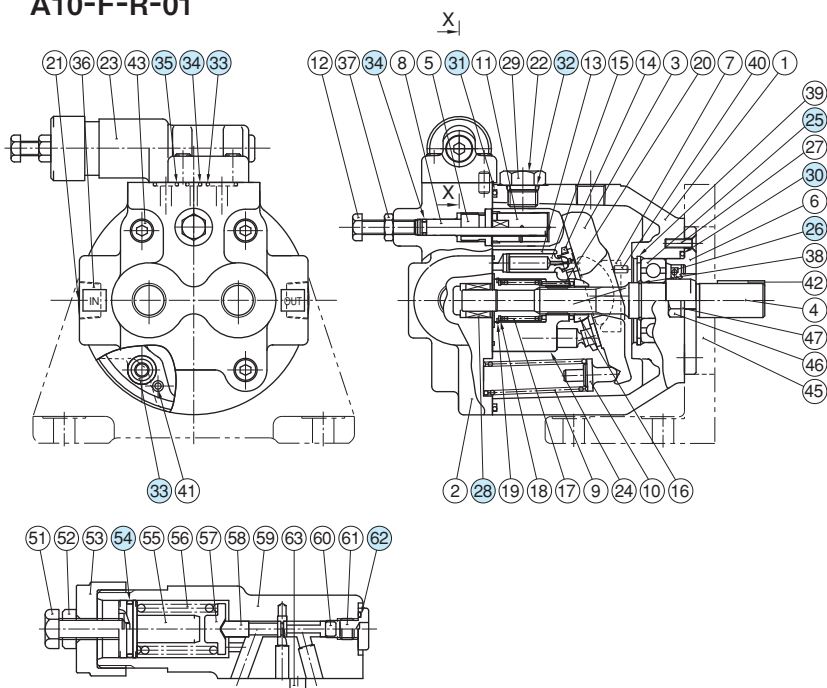

Section X-X

Item	Name of Parts	Part Numbers	Qty.
25	Bearing	6204	1
26	Oil Seal	TCN24408Y	1
28	Bearing	HMK1215	1
30	O-Ring	OR-NBR-70-1 G50-N	1
31	O-Ring	OR-NBR-90 G120-N	1
32	O-Ring	OR-NBR-90 P14-N	1
33	O-Ring	OR-NBR-90 P12-N	5
34	O-Ring	OR-NBR-90 P6-N	2
35	O-Ring	OR-NBR-90 P9-N	1
54	O-Ring	AS568-018 (NBR-70-1)	1
62	O-Ring	OR-NBR-90 P10-N	1

A16/A22/A37/A45/A56- * -R-01

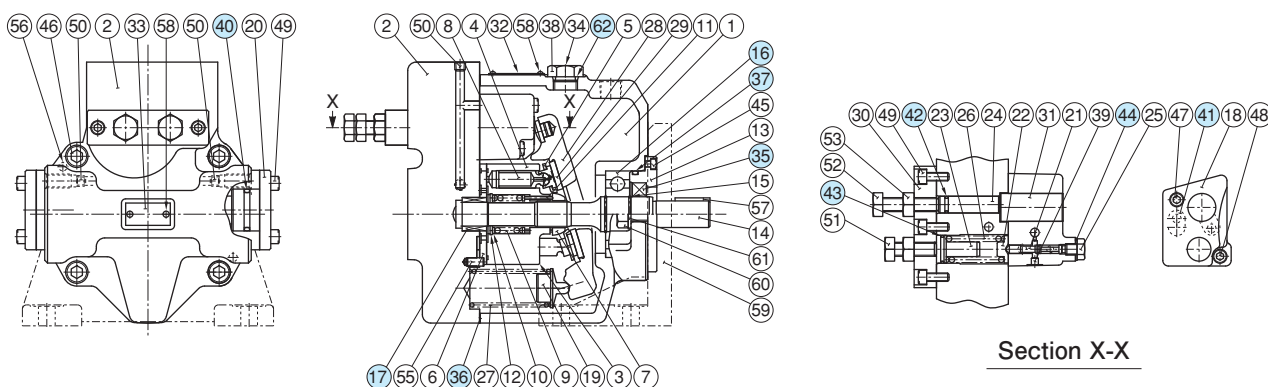

Section X-X

Item	Name of Parts	Part Numbers				Qty.
		A16- *-R-01	A22- *-R-01	A37- *-R-01 A45- *-R-01	A56- *-R-01	
16	Bearing	6305		6307	NUP 207E	1
17	Bearing	HMK 1715	Z30-1303-PK410300-8	HMK 2025V2	HMK 2530V2	1
35	Oil Seal	TCN 254511		TCN 355511	TCN 355511	1
36	Gasket	130-PK211969-1		1316-PK211970-9	1307-PK21197-7	1
37	O-Ring	OR-NBR-70-1 G55-N		OR-NBR-70-1 G75-N		1
40	O-Ring	OR-NBR-70-1 G25-N		OR-NBR-70-1 G30-N	OR-NBR-70-1 P36-N	2
41	O-Ring	OR-NBR-90 P12-N		OR-NBR-90 P10A-N		1
42	O-Ring	OR-NBR-90 P9-N				1
43	O-Ring	AS568-017 (NBR-70-1)				1
44	Seal Washer	W8				1
62	O-Ring	OR-NBR-90 P14-N				1

Spare Parts List

A70/A90/A100- *R01 * S

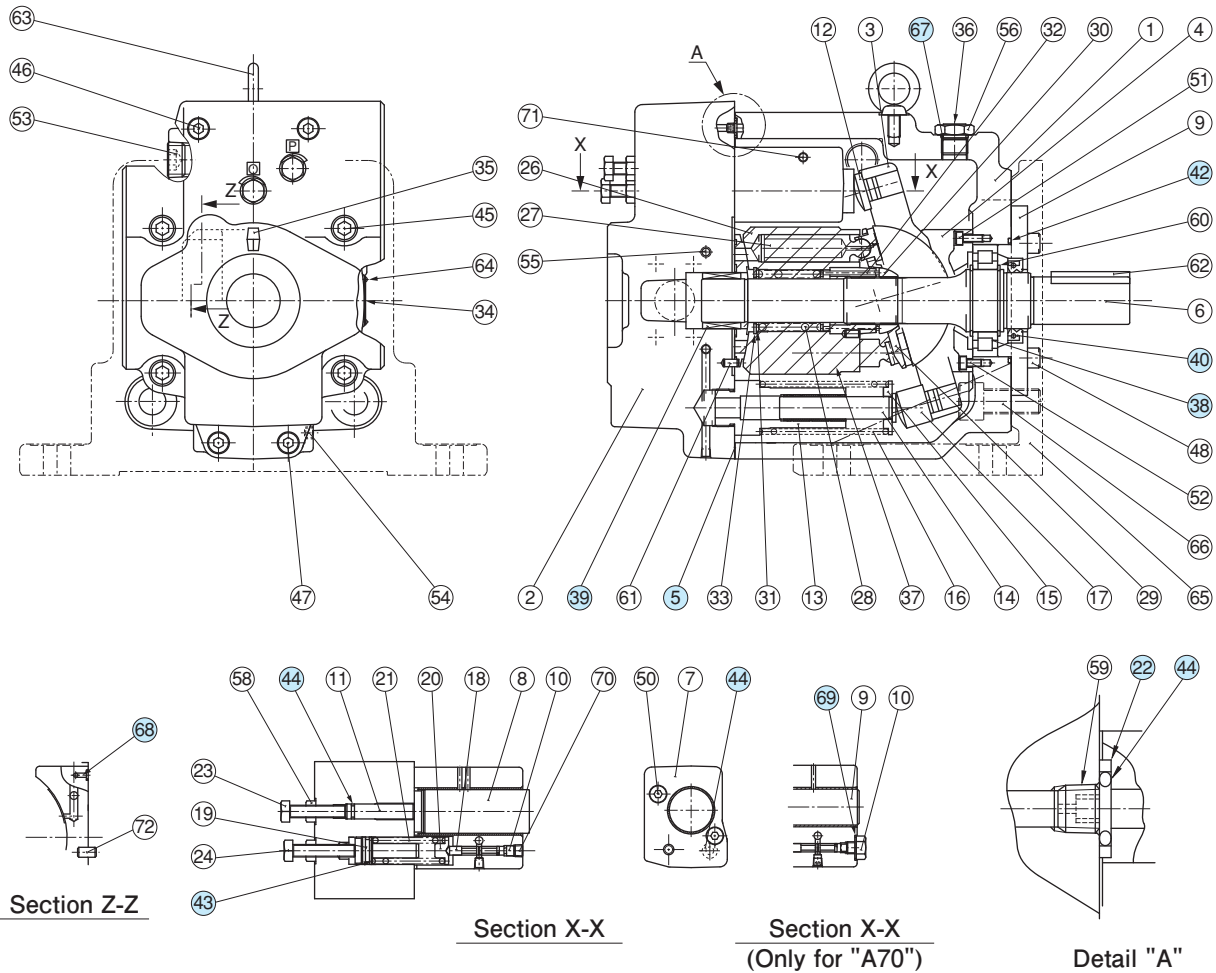

Item	Name of Parts	Part Numbers		Qty.
		A70- *R01 * S	A90- *R01 * S A100- *R01 * S	
5	Gasket	1314E-PK211972-5	1310E-PK211973-3	1
22	Back Up Ring	1310E-PK412440-0	1310E-PK412440-0	1
38	Bearing	NUP 208EX50	NUP 210E	1
39	Needle Bearing	HMK 3030V2	HMK 3530BV2	1
40	Oil Seal	TCN 355511 (FKM)	TCN 456812 (FKM)	1
42	O-Ring	OR-FKM-90 G85-N	OR-FKM-90 G95-N	1
43	O-Ring	OR-NBR-70-1 P18-N	OR-NBR-70-1 P18-N	1
44	O-Ring	OR-NBR-90 P9-N	OR-NBR-90 P9-N	3
67	O-Ring	OR-NBR-90 P14-N	OR-NBR-90 P18-N	1
68	O-Ring	OR-NBR-90 P5-N	OR-NBR-90 P5-N	1
69	Seal Washer	W10	—	1

Spare Parts List

A145-*R01*S

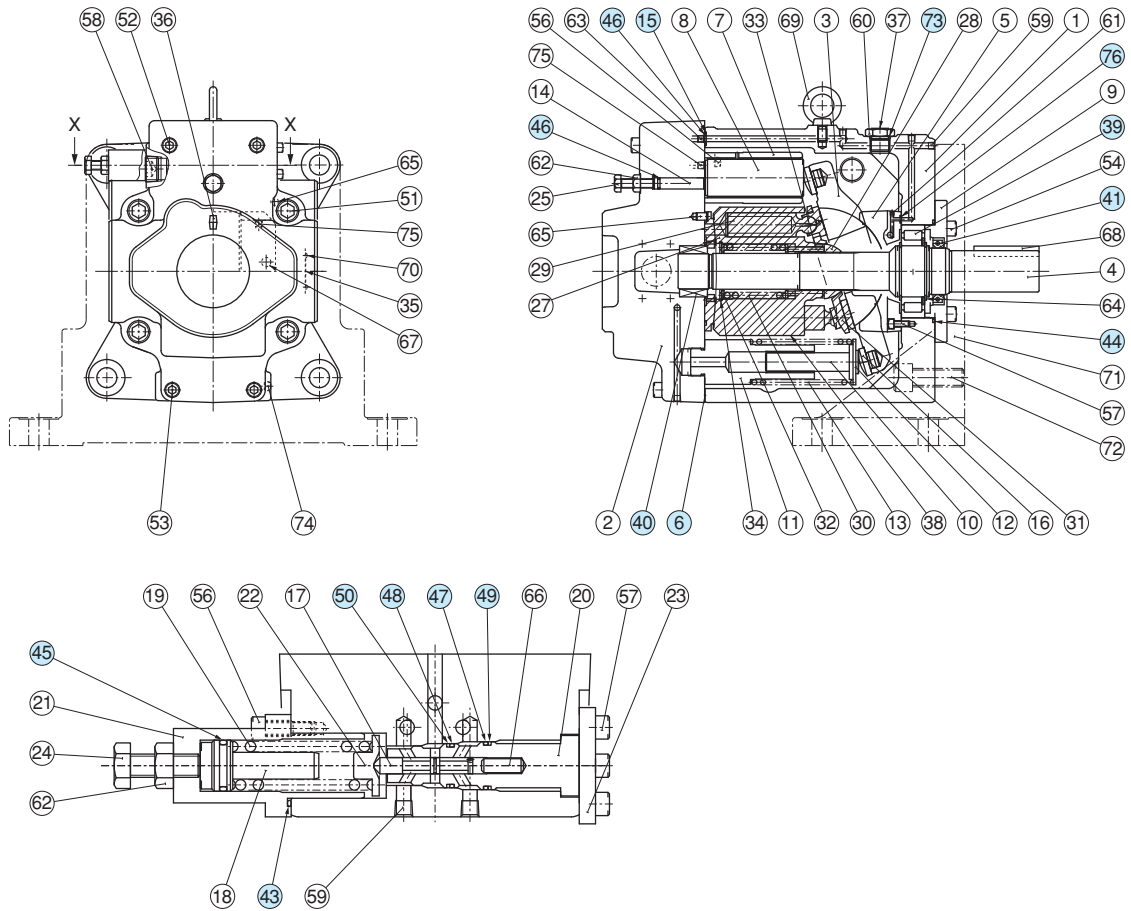

Section X-X

Item	Name of Parts	Part Numbers	Qty.
6	Gasket	1312-PK211974-1	1
15	Back Up Ring	1310E-PK412440-0	1
39	Bearing	NUP 2211ET2	1
40	Needle Bearing	8Q-NK38×55×30	1
41	Oil Seal	TCN 507212 (FKM)	1
43	O-Ring	S-31.5 (NBR-70)	1
44	O-Ring	OR FKM-90 G105-N	1
45	O-Ring	OR NBR-70-1 P18-N	1
46	O-Ring	OR NBR-90 P9-N	2
47	O-Ring	AS568-017 (NBR-70-1)	1
48	O-Ring	AS568-016 (NBR-70-1)	1
49	Back Up Ring	For AS568-017 (NBR-70-1)	1
50	Back Up Ring	For AS568-016 (NBR-70-1)	1
73	O-Ring	OR NBR-90 P18-N	1
76	O-Ring	OR NBR-90 P5-N	1

Series Variable Displacement Piston Pumps, Solenoid Two Pressure Control Type

Graphic Symbol

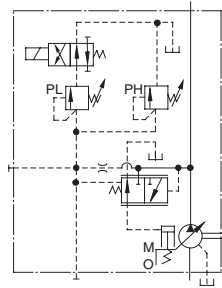

Performance Characteristics

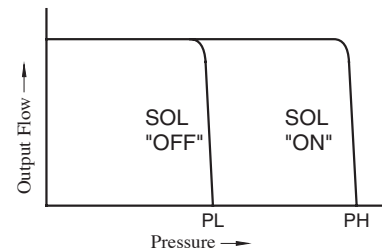

Specifications

Model Numbers	Geometric Displacement cm ³ /rev	Minimum Adj. Flow cm ³ /rev	Operating Pressure MPa		Minimum Adj. Pres. MPa	Shaft Speed Range r/min		Approx. Mass kg	
			Rated★2	Intermittent★1		Max.	Min.	Flange Mtg.	Foot Mtg.
A16- *-R-02- *-K *-32	15.8	4	16	21	1.2	1800	600	24.5	26.7
A22- *-R-02- *-K *-32	22.2	6	16	16	1.2	1800	600	24.5	26.7
A37- *-R-02- *-K *-32	36.9	10	16	21	1.2	1800	600	36	40.3
A56- *-R-02- *-K *-32	56.2	12	16	21	1.2	1800	600	43	47.3
A70- *R02S *-70	70.0	36	25	25	2	1800	600	63.5	75.5
A90- *R02S *-70	91.0	56	25	25	2	1800	600	80.5	101
A145- *R02S *-60	145	83	25	25	2	1800	600	97.5	122.5

★1. Whenever setting pressure, make sure the full cut-off pressure never exceeds the maximum intermittent pressure.

★2. When operating the pump exceeding the rated pressure, operating conditions are restricted. Refer to page A-28 for the details.

Solenoid Ratings

Electric Source	Coil Type	Frequency (Hz)	Voltage (V)		Current & Power at Rated Voltage		
			Source Rating	Serviceable Range	Inrush (A)★2	Holding (A)	Power (W)
AC	A100	50	100	80 - 110	2.42	0.51	—
			100	90 - 120	2.14	0.37	
					2.35	0.44	
	A120	50	120	96 - 132	2.02	0.42	
			108 - 144	1.78	0.31		
	A200	50	200	160 - 220	1.21	0.25	
			200	180 - 240	1.07	0.19	
					1.18	0.22	
	A240	50	240	192 - 264	1.01	0.21	
				216 - 288	0.89	0.15	
DC (K Series)	D12	—	12	10.8 - 13.2	—	2.45	29
	D24		24	21.6 - 26.4		1.23	
	D48		48	43.2 - 52.8		0.61	
AC→DC Rectified(R)★1	R100	50/60	100	90 - 110	—	0.33	29
	R200		200	180 - 220		0.16	

★1. R type models with built-in current rectifier is recommended for shockless operation with AC power.

★2. Inrush current in the above table show rms values at maximum stroke.

Model Number Designation

A16	-F	-R	-02	-S	-K	-A100	-32
Series Number	Mounting	Direction of Rotation	Control Type	Port Position	Shaft Extension	Coil Type of Solenoid Valve	Design Number
A16 (15.8 cm ³ /rev)	F: Flange Mtg. L: Foot Mtg.	(Viewed from Shaft End) R: Clockwise ^{★1} (Normal)	02: Solenoid Two Pressure Control Type	None: Axial Port S: Side Port	K: Keyed Shaft	AC A100, A120 A200, A240 DC D12, D24 D48 R (AC→DC Rectified) R100, R200	32
A22 (22.2 cm ³ /rev)							32
A37 (36.9 cm ³ /rev)							32
A56 (56.2 cm ³ /rev)							32

A70	-F	R	02	S	A100	-70
Series Number	Mounting	Direction of Rotation	Control Type	Port Position	Coil Type of Solenoid Valve	Design Number
A70 (70.0 cm ³ /rev)	F: Flange Mtg. L: Foot Mtg.	(Viewed from Shaft End) R: Clockwise ^{★1} (Normal)	02: Solenoid Two Pressure Control Type	S: Side Port	AC A100, A120 A200, A240 DC D12, D24 D48 R (AC→DC Rectified) R100, R200	70
A90 (91.0 cm ³ /rev)						70
A145 (145 cm ³ /rev)						60

★1. Available to supply pump with anti-clockwise rotation. Consult Yuken for details.

Performance Characteristics

For performance characteristics, refer to models of pressure compensator type on page A-32 to A-34, A-36 to A-38 and A-40.

Pipe Flange Kits

For pipe flange, refer to form of pressure compensator type on page A-29.

Axial Port Type

Flange Mtg. : A16-F-R-02-K
A22-F-R-02-K

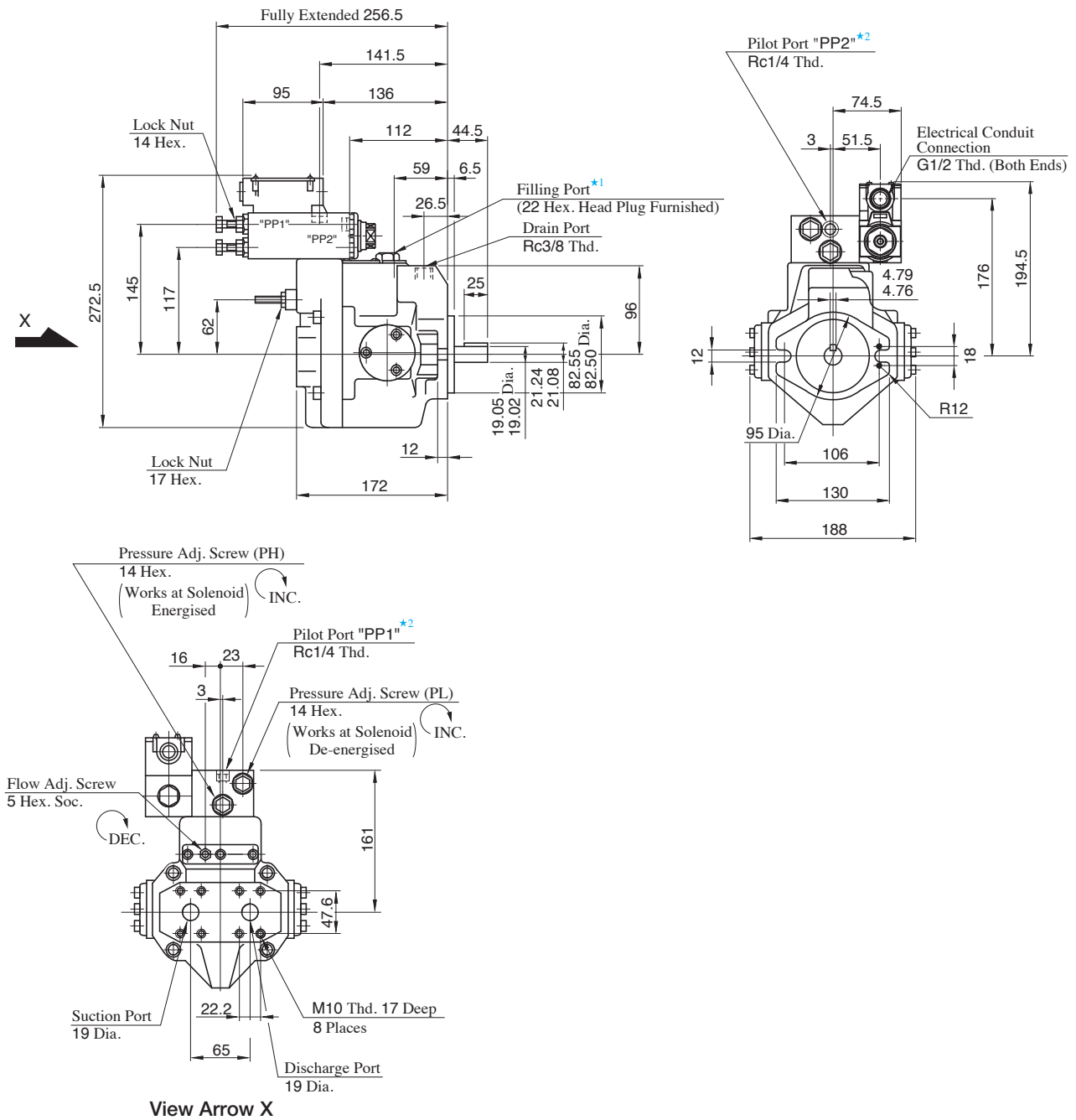

- ★1. Install the pump so that the "Filling Port" is at the top.
- ★2. The pilot port provided is for connecting a control valve, if multistage pressure control is required.

Side Port Type

Port mounting dimensions are the same as those of pressure compensator model. Refer to page A-42 for port mounting dimensions.

Foot Mounting Type

Mounting bracket is common to that of pressure compensator model. Refer to page A-42 for the dimensions of mounting bracket.

Side Port Type

Flange Mtg. : A37-F-R-02-S-K

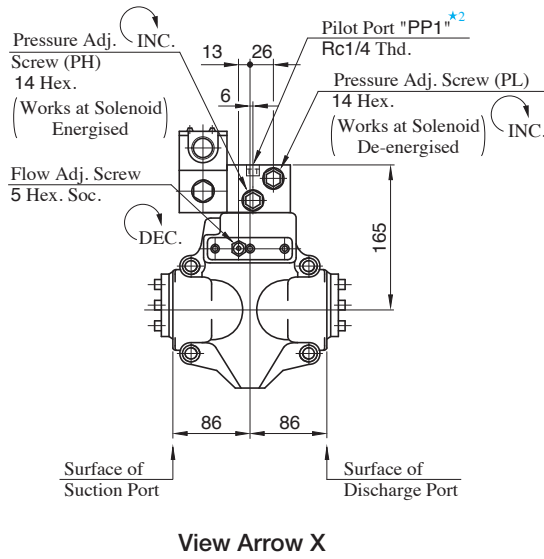
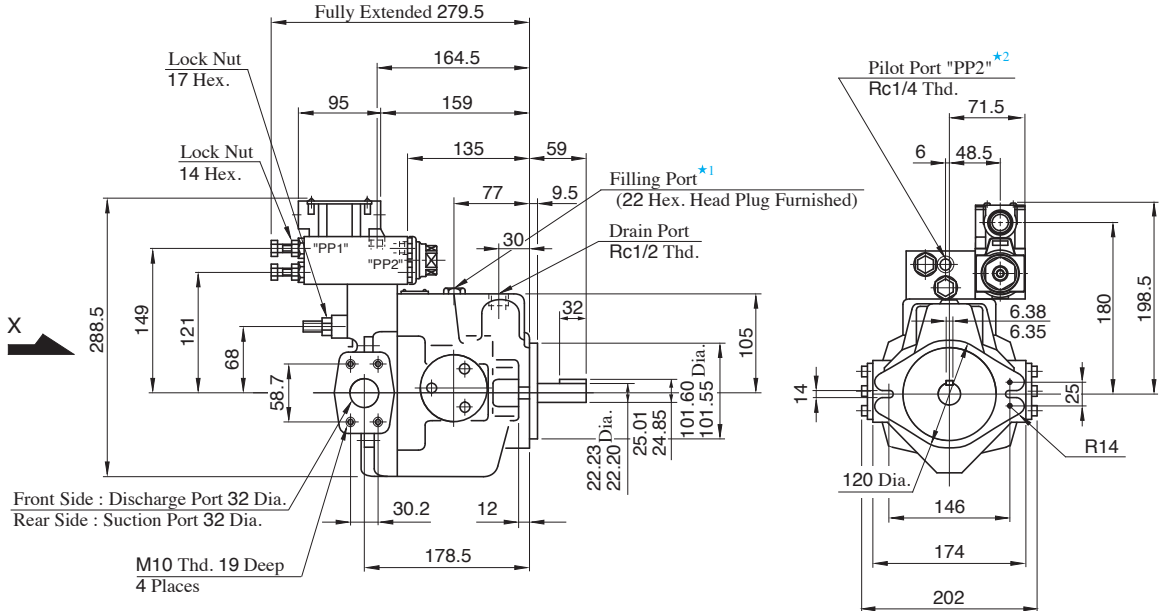

- ★1. Install the pump so that the "Filling Port" is at the top.
- ★2. The pilot port provided is for connecting a control valve, if multistage pressure control is required.

● Axial Port Type

Port mounting dimensions are the same as those of pressure compensator model.
Refer to page A-43 for port mounting dimensions.

● Foot Mounting Type

Mounting bracket is common to that of pressure compensator model.
Refer to page A-43 for the dimensions of mounting bracket.

Side Port Type

Flange Mtg. : A56-F-R-02-S-K

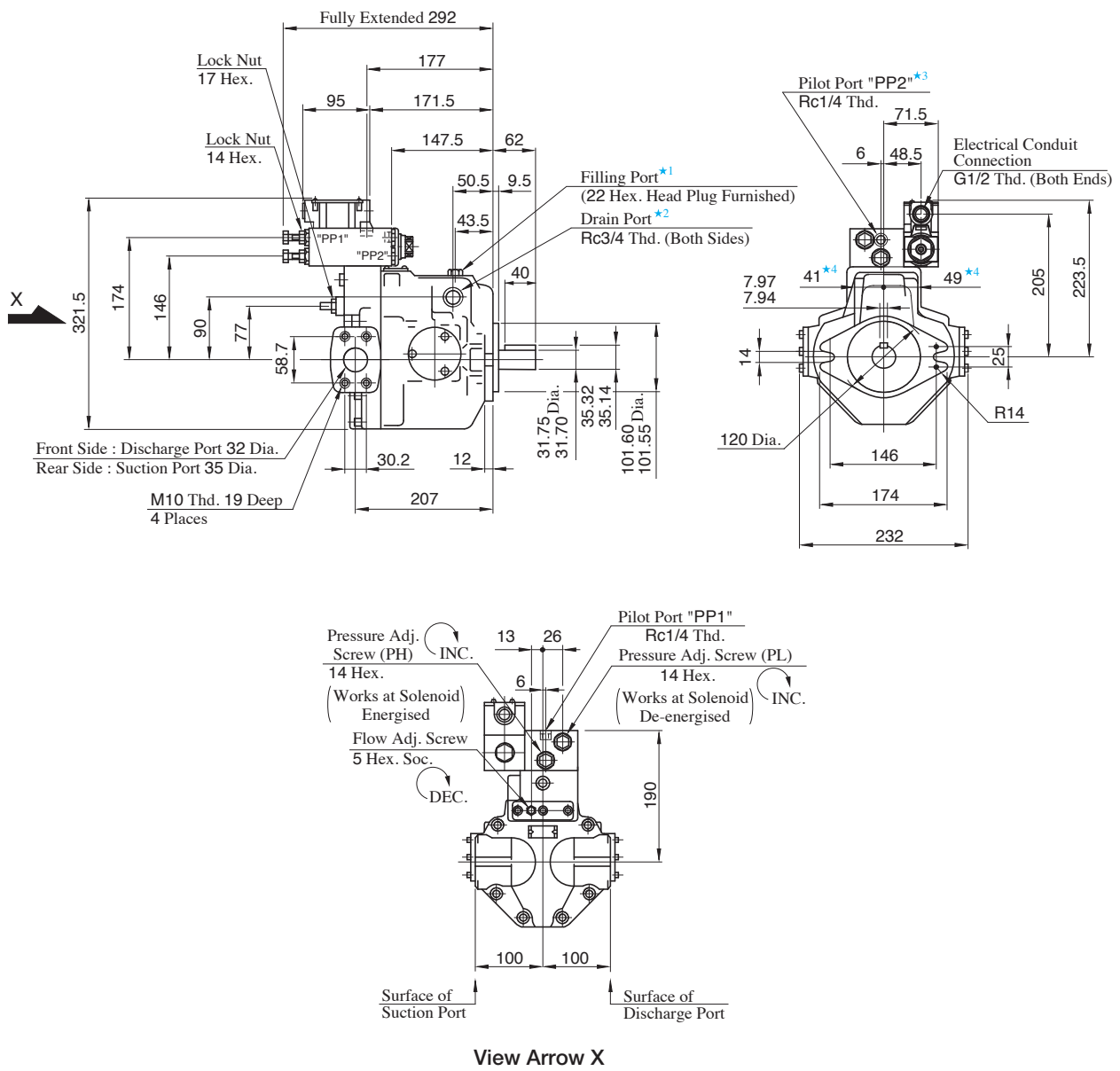

- ★1. Install the pump so that the "Filling Port" is at the top.
- ★2. Use either port of two drain ports at your option. Keep the remaining port plugged.
- ★3. The pilot port provided is for connecting a control valve, if multistage pressure control is required.
- ★4. Dimensions show surface of drain port.

● Axial Port Type

Port mounting dimensions are the same as those of pressure compensator model. Refer to page A-44 for port mounting dimensions.

● Foot Mounting Type

Mounting bracket is common to that of pressure compensator model. Refer to page A-44 for the dimensions of mounting bracket.

Flange Mtg. : A70-FR02 *

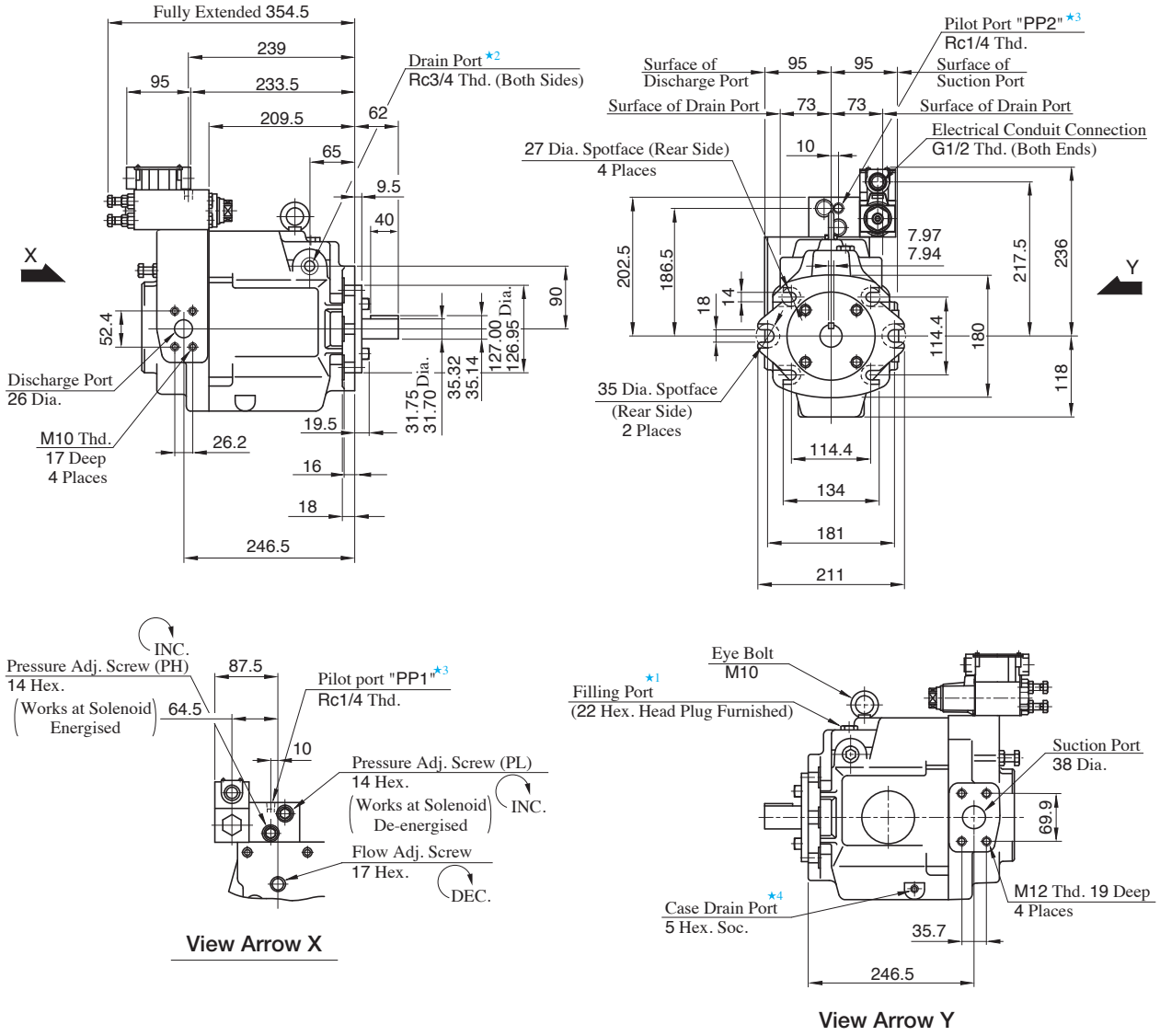

- ★1. Install the pump so that the "Filling Port" is at the top.
- ★2. Use either port of two drain ports at your option. Keep the remaining port plugged.
- ★3. The pilot port provided is for connecting a control valve, if multistage pressure control is required.
- ★4. Case drain port is available for use when draining hydraulic fluid from pump casing.

● Foot Mounting Type

Mounting bracket is common to that of pressure compensator model.
Refer to page A-45 for the dimensions of mounting bracket.

Flange Mtg. : A90-FR02 *

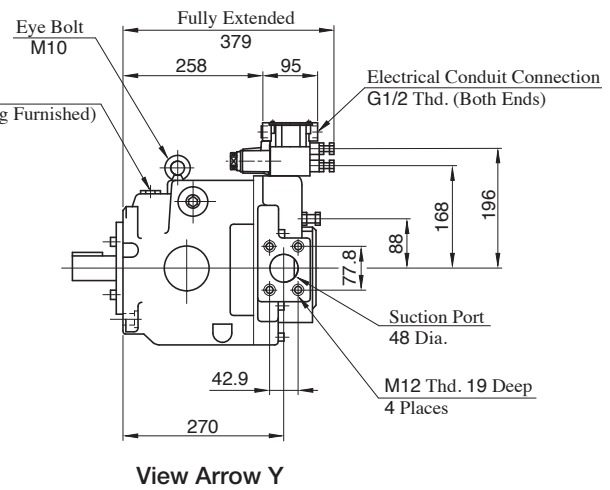
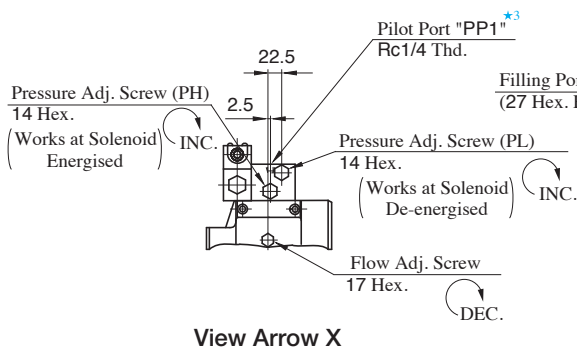
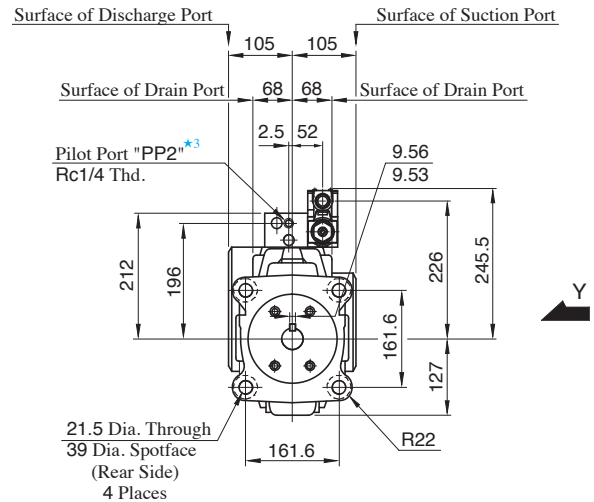
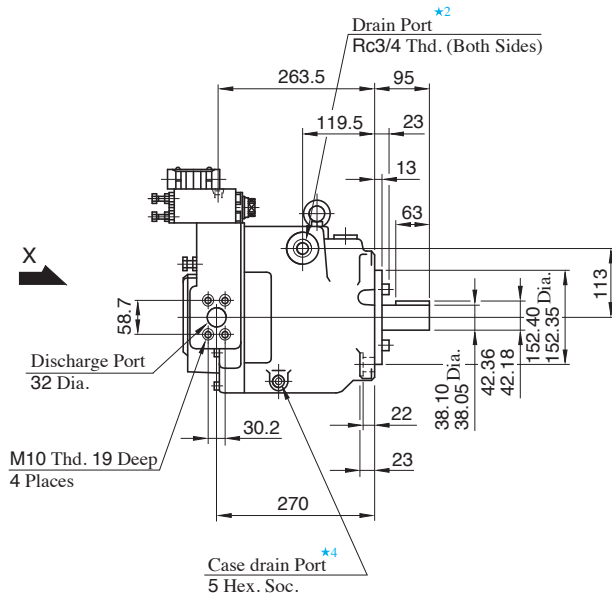

- ★1. Install the pump so that the "Filling Port" is at the top.
- ★2. Use either port of two drain ports at your option. Keep the remaining port plugged.
- ★3. The pilot port provided is for connecting a control valve, if multistage pressure control is required.
- ★4. Case drain port is available for use when draining hydraulic fluid from pump casing.

● Foot Mounting Type

Mounting bracket is common to that of pressure compensator model.
Refer to page A-46 for the dimensions of mounting bracket.

Flange Mtg. : A145-FR02 *

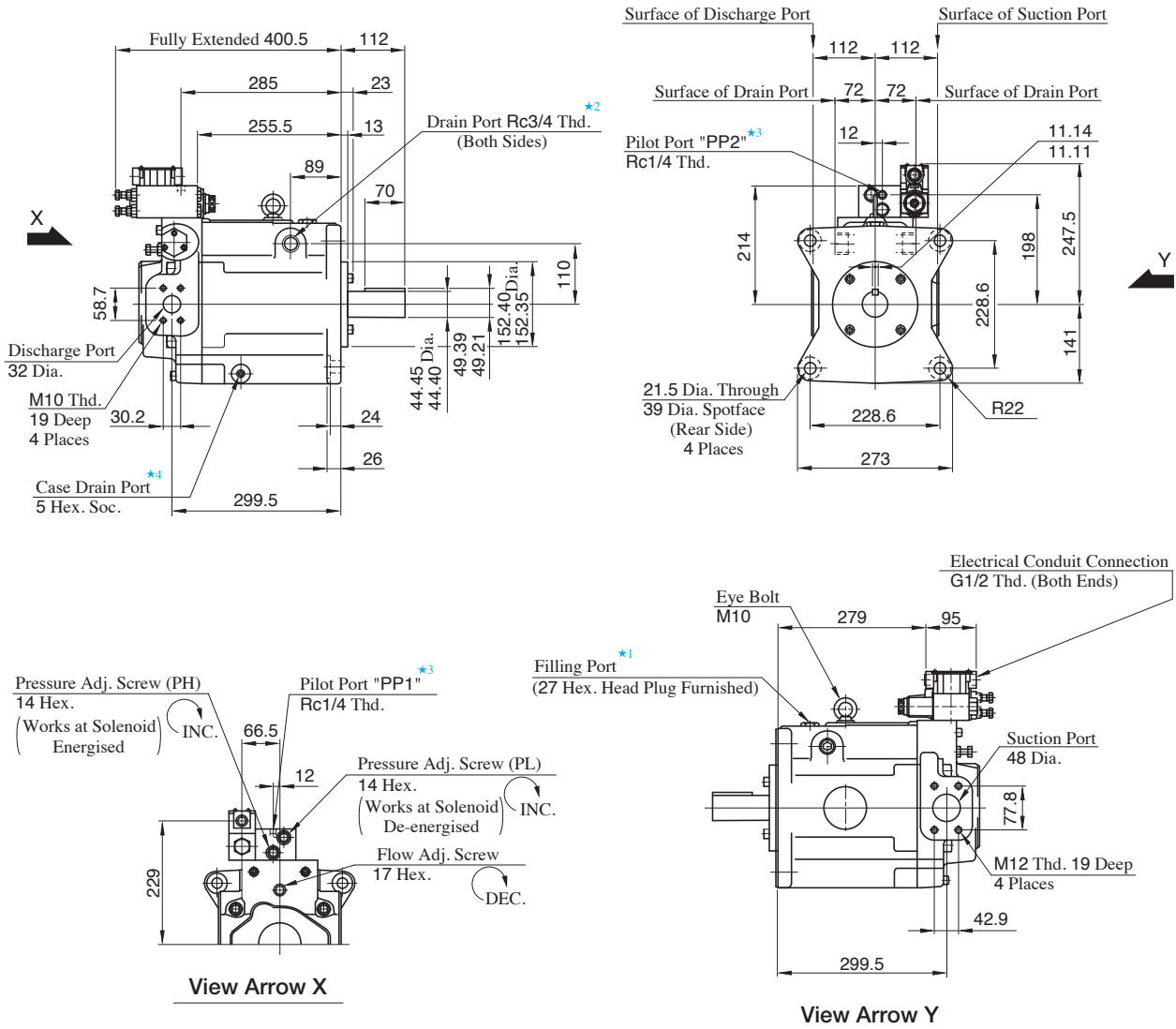

- ★1. Install the pump so that the "Filling Port" is at the top.
- ★2. Use either port of two drain ports at your option. Keep the remaining port plugged.
- ★3. The pilot port provided is for connecting a control valve, if multistage pressure control is required.
- ★4. Case drain port is available for use when draining hydraulic fluid from pump casing.

● Foot Mounting Type

Mounting bracket is common to that of pressure compensator model.
Refer to page A-47 for the dimensions of mounting bracket.

Series Variable Displacement Piston Pumps, Pressure Compensator with Unloading Type

Graphic Symbol

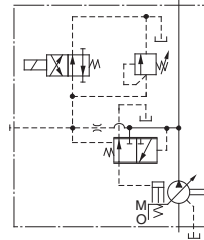

Performance Characteristics

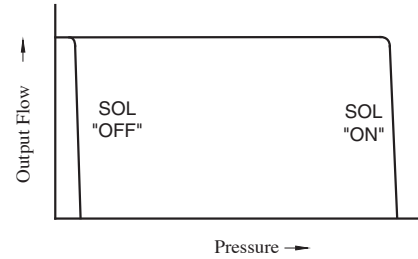

Specifications

Model Numbers	Geometric Displacement cm ³ /rev	Minimum Adj. Flow cm ³ /rev	Operating Pressure MPa		Unloading Pressure MPa	Shaft Speed Range r/min	
			Rated	Intermittent		Max.	Min.
A16- *-R-03- *-K- *-32	15.8	4	16	21	1.2	1800	600
A22- *-R-03- *-K- *-32	22.2	6	16	16	1.2	1800	600
A37- *-R-03- *-K- *-32	36.9	10	16	21	1.2	1800	600
A56- *-R-03- *-K- *-32	56.2	12	16	21	1.2	1800	600
A70- *R03S* -70	70.0	36	25	25	1.2	1800	600
A90- *R03S* -70	91.0	56	25	25	1.2	1800	600
A145- *R03S* -60	145	83	25	25	1.2	1800	600

Model Number Designation

A16	-F	-R	-03	-S	-K	-A100	-32
Series Number	Mounting	Direction of Rotation	Control Type	Port Position	Shaft Extension	Coil Type of Solenoid Valve	Design Number
A16 (15.8 cm ³ /rev)	F: Flange Mtg. L: Foot Mtg.	(Viewed from Shaft End) R: Clockwise ^{*1} (Normal)	03: Pressure Compensator with Unloading Type	None: Axial Port S: Side Port	K: Keyed Shaft	AC A100, A120 A200, A240 DC D12, D24 D48 R (AC→DC Rectified) R100, R200	32
A22 (22.2 cm ³ /rev)							32
A37 (36.9 cm ³ /rev)							32
A56 (56.2 cm ³ /rev)							32

A70	-F	R	03	S	A100	-70
Series Number	Mounting	Direction of Rotation	Control Type	Port Position	Coil Type of Solenoid Valve	Design Number
A70 (70.0 cm ³ /rev)	F: Flange Mtg. L: Foot Mtg.	(Viewed from Shaft End) R: Clockwise ^{*1} (Normal)	03: Pressure Compensator with Unloading Type	S: Side Port	AC A100, A120 A200, A240 DC D12, D24 D48 R (AC→DC Rectified) R100, R200	70
A90 (91.0 cm ³ /rev)						70
A145 (145 cm ³ /rev)						60

*1. Available to supply pump with anti-clockwise rotation. Consult Yuken for details.

Consult Yuken when detailed material such as dimensions figures is required.

Series Variable Displacement Piston Pumps, Proportional Electro-Hydraulic Load Sensing Type

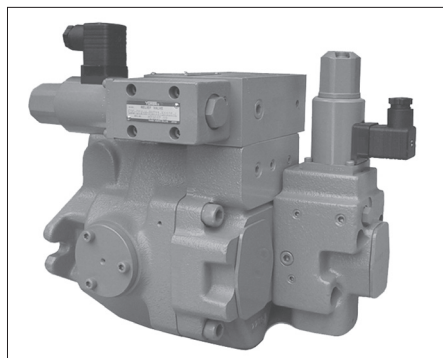

Performance Characteristics

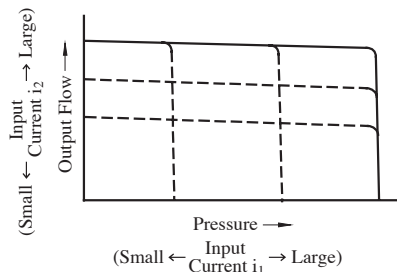

Graphic Symbols

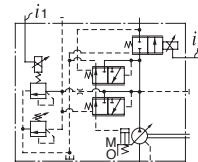

A16/A22/A37/A56

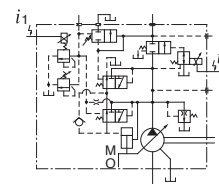

A70/A90/A100/A145

Model Number Designation

A56	-F	-R	-04	-C	-K	-32
Series Number	Mounting	Direction of Rotation	Control Type	Pressure Adj. Range MPa	Shaft Extension	Design Number
A16 (15.8 cm ³ /rev)	F: Flange Mtg. L: Foot Mtg.	(Viewed from) Shaft End R: Clockwise ^{★1}	04: Proportional Electro-Hydraulic Load Sensing Type	B: 1.5 - 6.9 (220 - 1000) C: 1.5 - 15.7 (220 - 2280) H: 1.5 - 20.6 (220 - 2990)	K: Keyed Shaft	32
A22 (22.2 cm ³ /rev)				B: 1.5 - 6.9 (220 - 1000) C: 1.5 - 15.7 (220 - 2280)		32
A37 (36.9 cm ³ /rev)				B: 2 - 6.9 (290 - 1000) C: 2 - 15.7 (290 - 2280) H: 2 - 20.6 (290 - 2990)		32
A56 (56.2 cm ³ /rev)				B: 2 - 6.9 (290 - 1000) C: 2 - 15.7 (290 - 2280) H: 2 - 20.6 (290 - 2990)		32

A70	-F	R	04	C	S	-70
Series Number	Mounting	Direction of Rotation	Control Type	Pressure Adj. Range MPa	Port Position	Design Number
A70 (70.0 cm ³ /rev)	F: Flange Mtg. L: Foot Mtg.	(Viewed from) Shaft End R: Clockwise ^{★1}	04: Proportional Electro-Hydraulic Load Sensing Type	C: 1.5 - 16 (220 - 2320) H: 1.5 - 21 (220 - 3050)	S: Side Port	70
A90 (91.0 cm ³ /rev)						70
A100 (100 cm ³ /rev)						20
A145 (145 cm ³ /rev)						60

★1. Available to supply pump with anti-clockwise rotation. Consult Yuken for details.

Pipe Flange Kits

Pipe flange kits are available. When ordering, specify the kit number from the table below.

Pump Model Numbers	Name of Port	Pipe Flange Kit Numbers		
		Threaded Connection	Socket Welding ^{*1}	Butt Welding
A16- *-R-04	Suction	F5-06-A-10	F5-06-B-10	F5-06-C-10
A22- *-R-04	Discharge	— ^{*2}	— ^{*2}	— ^{*2}
A37- *-R-04	Suction	F5-10-A-10	F5-10-B-10	F5-10-C-10
A56- *-R-04	Discharge	F5-06-A-10	F5-06-B-10	F5-06-C-10
A 70- *R04	Suction	F5-12-A-10	F5-12-B-10	F5-12-C-10
	Discharge	F5-10-A-10	F5-10-B-10	F5-10-C-10
A 90- *R04	Suction	F5-16-A-10	F5-16-B-10	F5-16-C-10
A100- *R04		F5-10-A-10	F5-10-B-10	F5-10-C-10
A145- *R04				

★1. In case of using socket welding flanges, there is a case where the operating pressure should be set lower than the normal because of strength of the flanges. Therefore, please pay cautious attention to the operating pressure when the socket welding flanges are used.

★2. Discharge port for pump model "A16" and "A22" is available only the threaded connections.

● Details of the pipe flange kits are shown on pages A-258 and A-259.

Instructions

Bleeding Air

In order to get steadily controlled pressure and flow, bleed air by loosening the air vent screw and fill solenoid armature with operating oil.

Manual Adjustment Screws

Manual adjustment screws may be used for initial running adjustment or in case of electrical failures in order to adjust pressure and flow temporarily. In case of normal use, put the manual adjustment screws back in their preset positions.

Position of Cable Departure

Position of cable departure can be changed. For details, refer to drawing below.

Connection of Surge Cut-off Valve to "A" Series Pump (For A16 to A56 Type)

If using surge cut-off valve (SF1105-A-10), connect between pilot port "PP" of this pump and port "PP" of surge cut-off valve as pilot piping (refer to symbol below).

Inside diameter of pipe should be more than 8 mm.

Consult Yuken for details of surge cut-off valve.

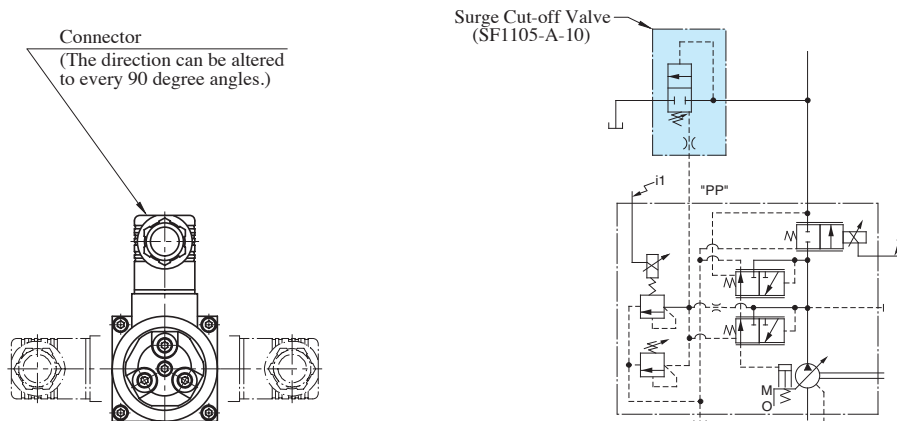

Specifications

Descriptions		Model Numbers		A16	A22	A37	A56	A70	A90	A100	A145
Geometric Displacement		cm ³ /rev		15.8	22.2	36.9	56.2	70.0	91.0	100	145
Operating Pressure MPa		Rated ^{*2}		16	16	16	16	21	21	21	21
		Intermittent ^{*1}		21	16	21	21	21	21	21	21
Shaft Speed Range r/min		Max.		1800	1800	1800	1800	1800	1800	1800	1800
		Min.		600	600	600	600	600	600	600	600
Flow Control	Flow Adj. Range	L/min		1 - 28.4	1 - 40	1 - 66	1 - 101	1 - 126	1 - 163	1 - 180	2 - 261
	Min. Pres. Required for Flow Adj.	MPa		1.5	1.5	1.5	2.0	1.0	1.0	1.0	1.0
	Differential Pres. (Discharge Pres. - Load Pres.)	MPa		0.37				0.22			
	Step Response ^{*5} (0 → Max. Flow)	ms		70	80	120	125	100	120	120	210
	Hysteresis			3 % or less ^{*1}							
	Rated Current	mA		900	700	740	790	820	920	945	920
	Coil Resistance (20°C)	Ω		10							
Pres. Control	Pres. Adj. Range	MPa		Refer to Model Number Designation							
	Step Response ms	t ₁ ^{*5}		80	80	50	55	150	150	150	160
		t ₂ ^{*5}		140	90	80	80	80	120	120	180
	Hysteresis			2 % or less ^{*1}							
	Rated Current	mA		(Pres. Adj. Range) B: 770, C: 880, H: 790				C: 860 H: 765	C: 873 H: 765	C: 873 H: 765	C: 875 H: 755
Coil Resistance (20°C)	Ω		10								
Applicable Amplifier Model ^{*3}				AME-D2-1010-11							
Approx. Mass kg	Flange Mtg.		32	32	38	45	70	88.5	88	109.5	
	Foot Mtg.		34.2	34.2	43.2	49.3	82	109	104	134.5	

- ★1. Whenever setting pressure, make sure the full cut-off pressure never exceeds the maximum intermittent pressure.
- ★2. When operating the pump exceeding the rated pressure, operating conditions are restricted. Refer to page A-28 for details.
- ★3. Specifications of power amplifiers, consult Yuken for details.
- ★4. The figure mentioned in the above table are those obtained using Yuken's amplifier.
- ★5. Step response depends on circuit and operating conditions. Data shown in the table above is an example based on the condition right.

Model	Pres. Step Response		Loading Volume
	t ₁	t ₂	
A16, A22	1.5 → 16 MPa	16 → 1.5 MPa	High Pressure Hose 3/8" × 2 m
A37, A56	2.0 → 16 MPa	16 → 2.0 MPa	High Pressure Hose 3/4" × 2 m
A70, A90 A100, A145	3.0 → 16 MPa	16 → 3.0 MPa	High Pressure Hose 1-1/4" × 2 m

Typical Performance Characteristics at Viscosity 20 mm²/s [ISO VG32 Oils, 50°C]

Full Cut-off Pres. vs. Input Signal

● A16/A22/A37/A56

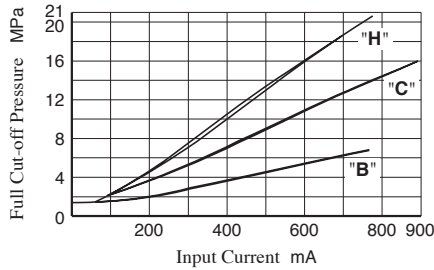

● A70/A90/A100/A145

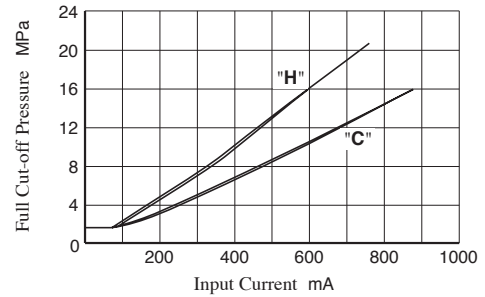

Note: Pressure adjustment range "H" is not available for A22.

Output Flow vs. Input Current

● A16

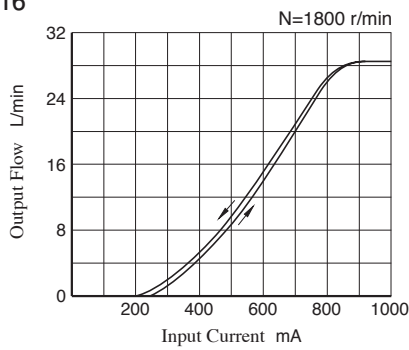

● A70

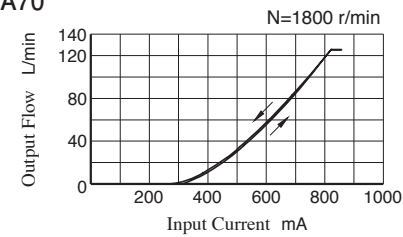

● A22

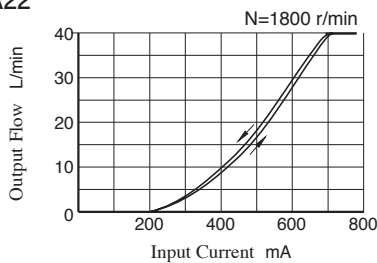

● A90

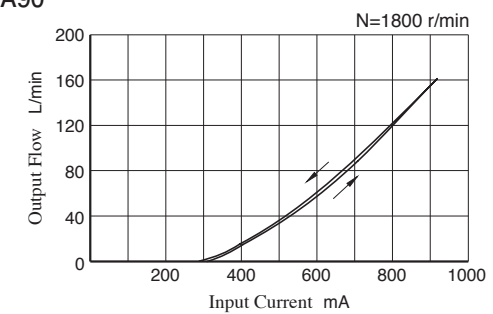

● A37

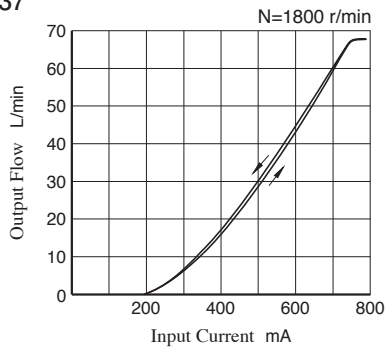

● A100

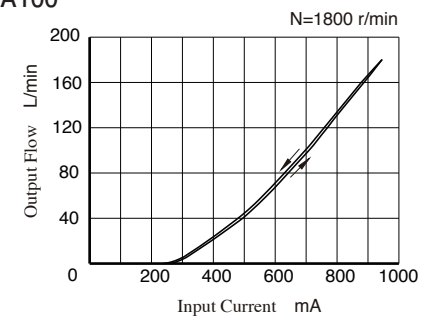

● A56

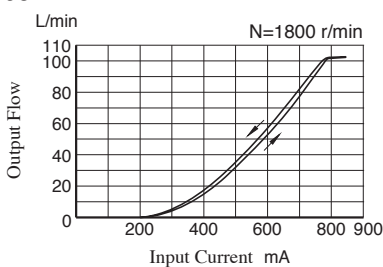

● A145

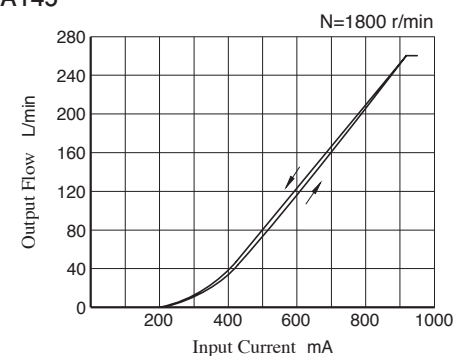

Flange Mtg. : A16-F-R-04 * -K
A22-F-R-04 * -K

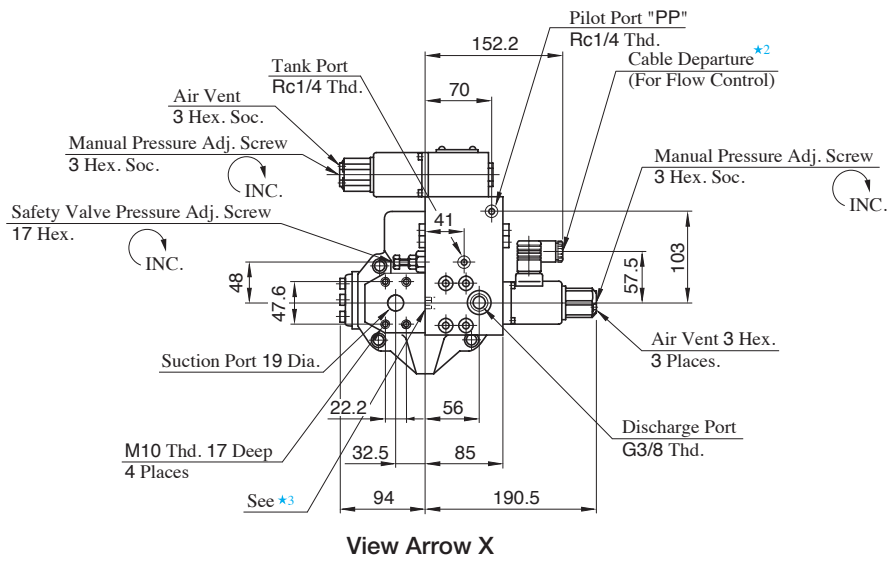
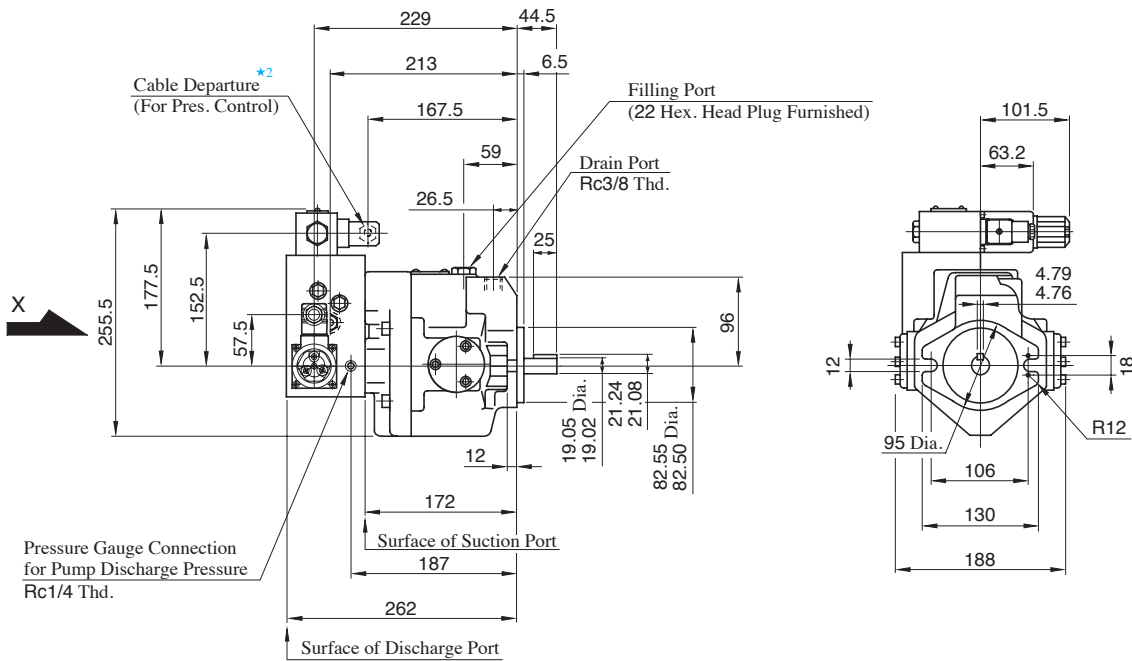

★ 1. Detail of Discharge Port

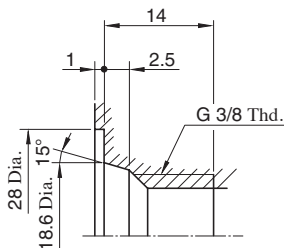

★ 2. Cable Applicable:

Outside Dia.....8-10 mm
Conductor Area.....Not Exceeding 1.5 mm²

★ 3. Do not touch the screw because it is adjusted at the time of shipment.

● Foot Mounting Type

Mounting bracket is common to that of pressure compensator model.
Refer to page A-42 for the dimensions of mounting bracket.

Flange Mtg. : A37-F-R-04 *-K

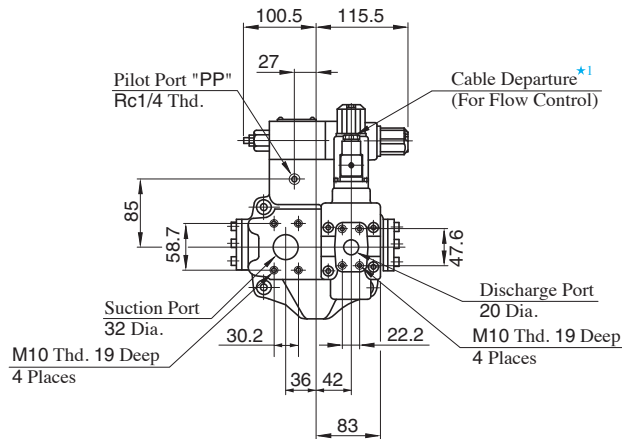
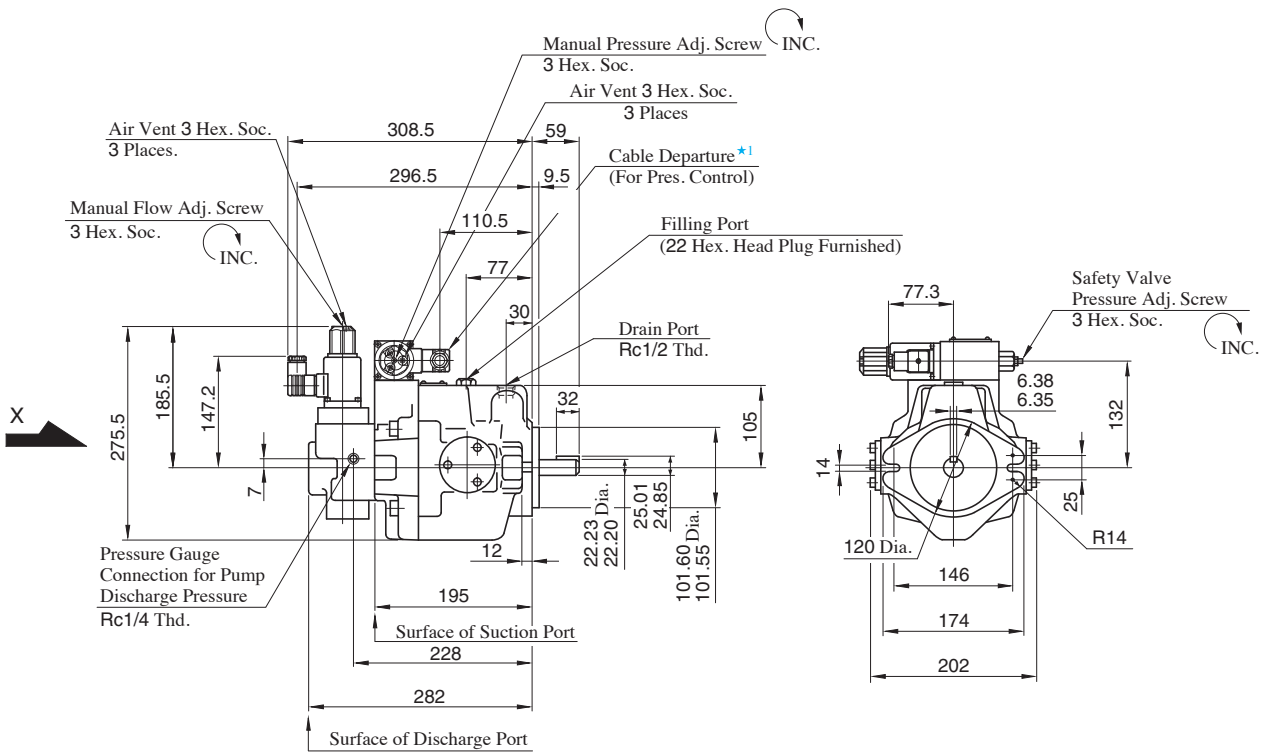

★1. Cable Applicable:
 Outside Dia.....8-10 mm
 Conductor Area.....Not Exceeding 1.5 mm²

View Arrow X

Foot Mtg. : A37-L-R-04 *-K

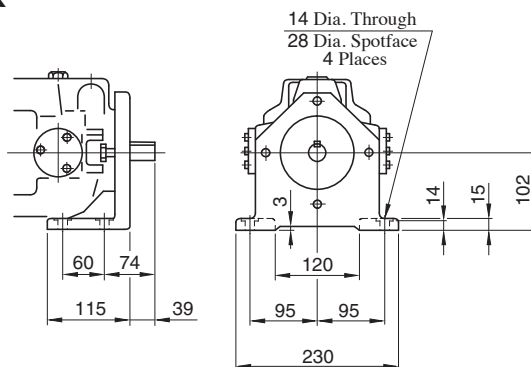

● For other dimensions, refer to "Flange Mtg.".

Flange Mtg. : A56-F-R-04 *-K

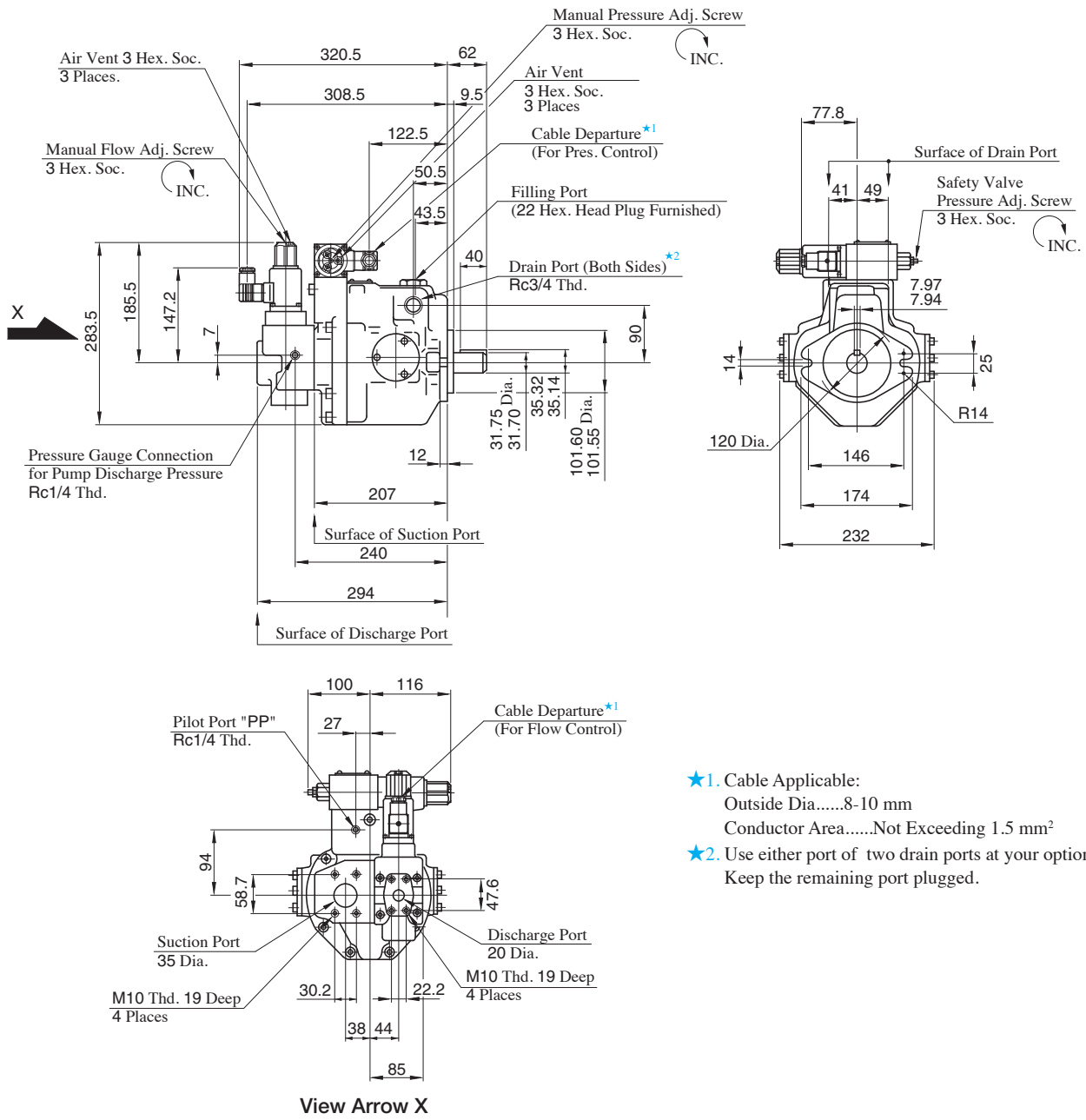

Foot Mtg. : A56-L-R-04 *-K

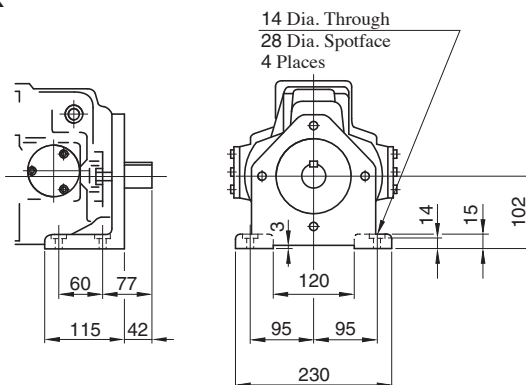

● For other dimensions, refer to "Flange Mtg."

Flange Mtg. : A70-FR04 * S

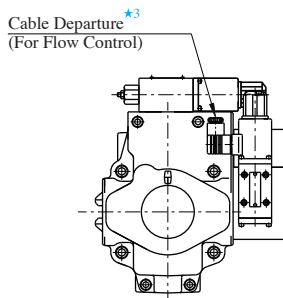
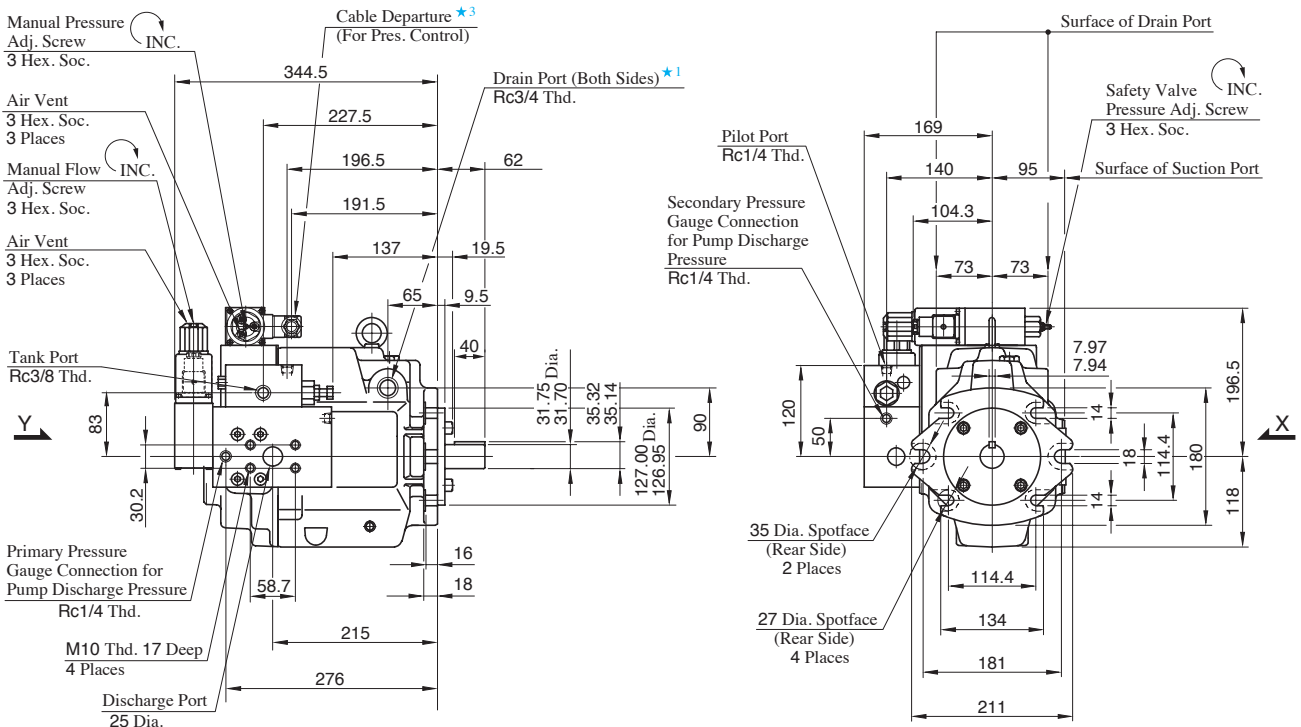

View Arrow Y

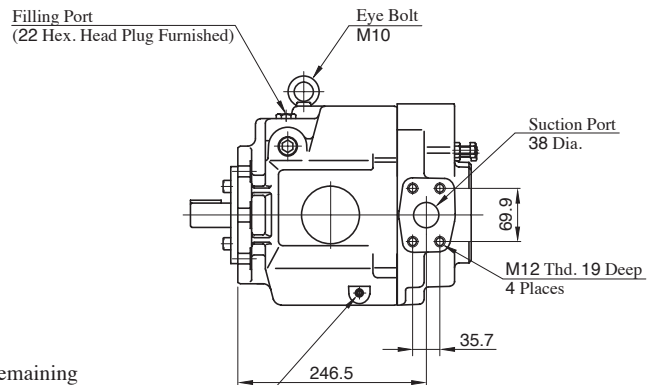

View Arrow X

- ★1. Use either port of two drain ports at your option. Keep the remaining port plugged.
- ★2. Case drain port is available for use when draining hydraulic fluid from pump casing.
- ★3. Cable Applicable:
Outside Dia.....8-10 mm
Conductor Area.....Not Exceeding 1.5 mm²

Foot Mtg. : A70-LR04 * S

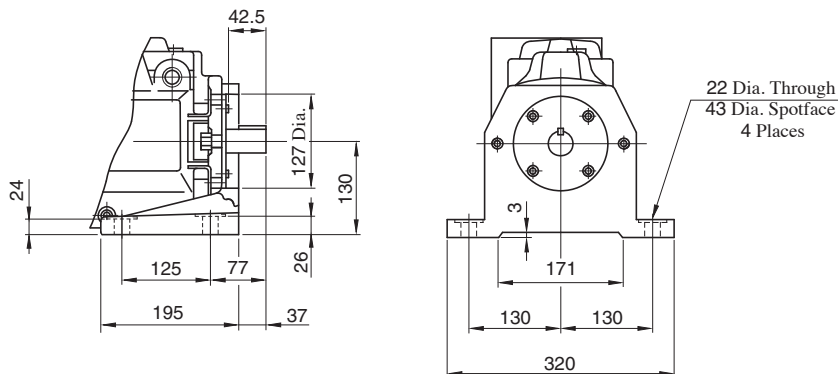

● For other dimensions, refer to "Flange Mtg.".

**Flange Mtg. : A90-FR04 * S
A100-FR04 * S**

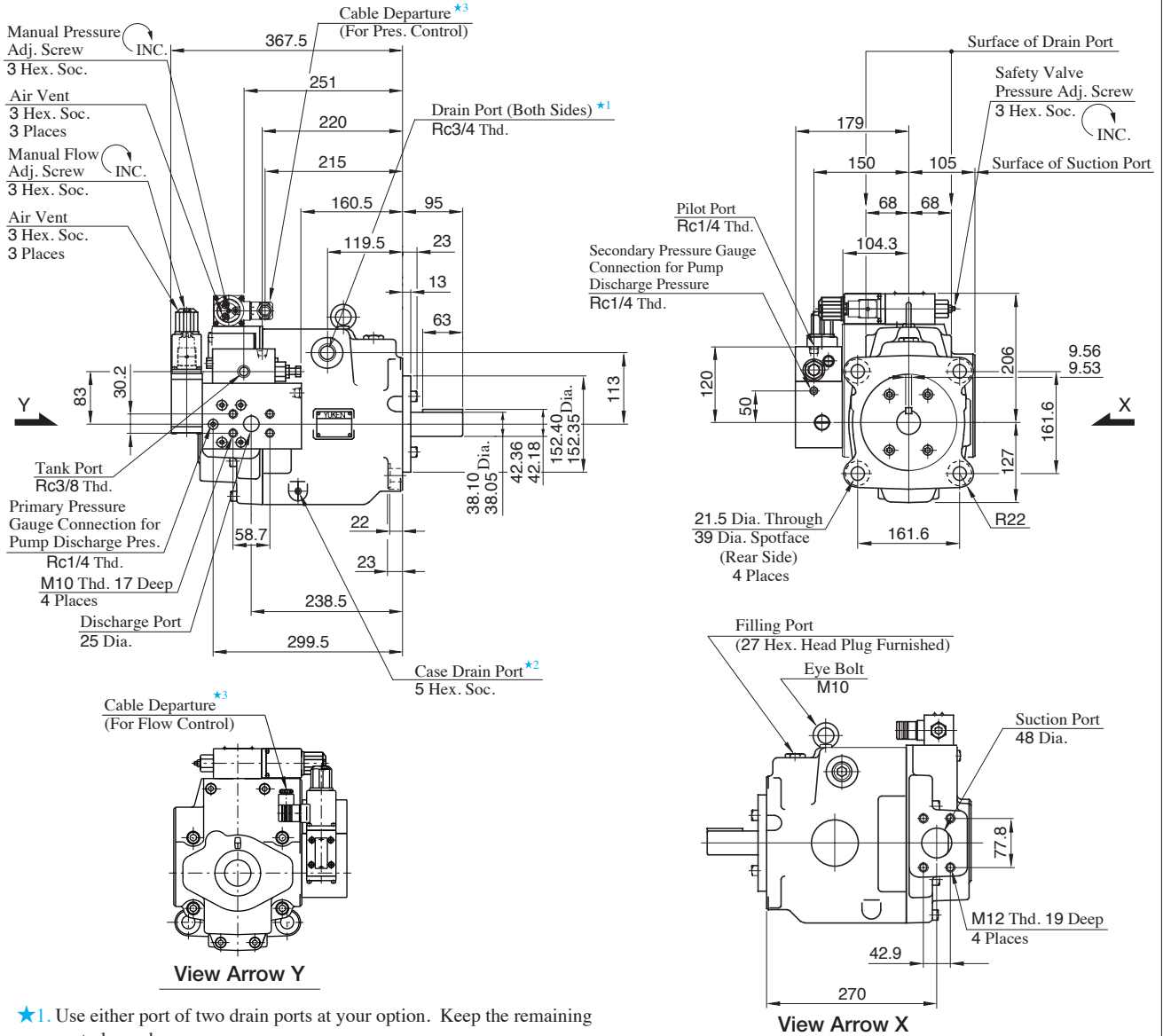

- ★1. Use either port of two drain ports at your option. Keep the remaining port plugged.
- ★2. Case drain port is available for use when draining hydraulic fluid from pump casing.
- ★3. Cable Applicable:
 Outside Dia.....8-10 mm
 Conductor Area.....Not Exceeding 1.5 mm²

Foot Mtg. : A90-LR04 * S

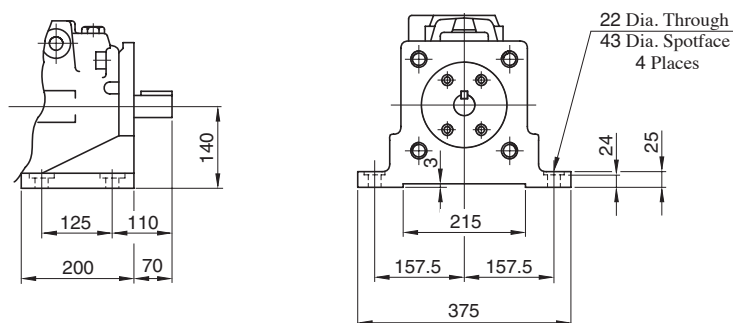

● For other dimensions, refer to "Flange Mtg.".

Flange Mtg. : A145-FR04 * S

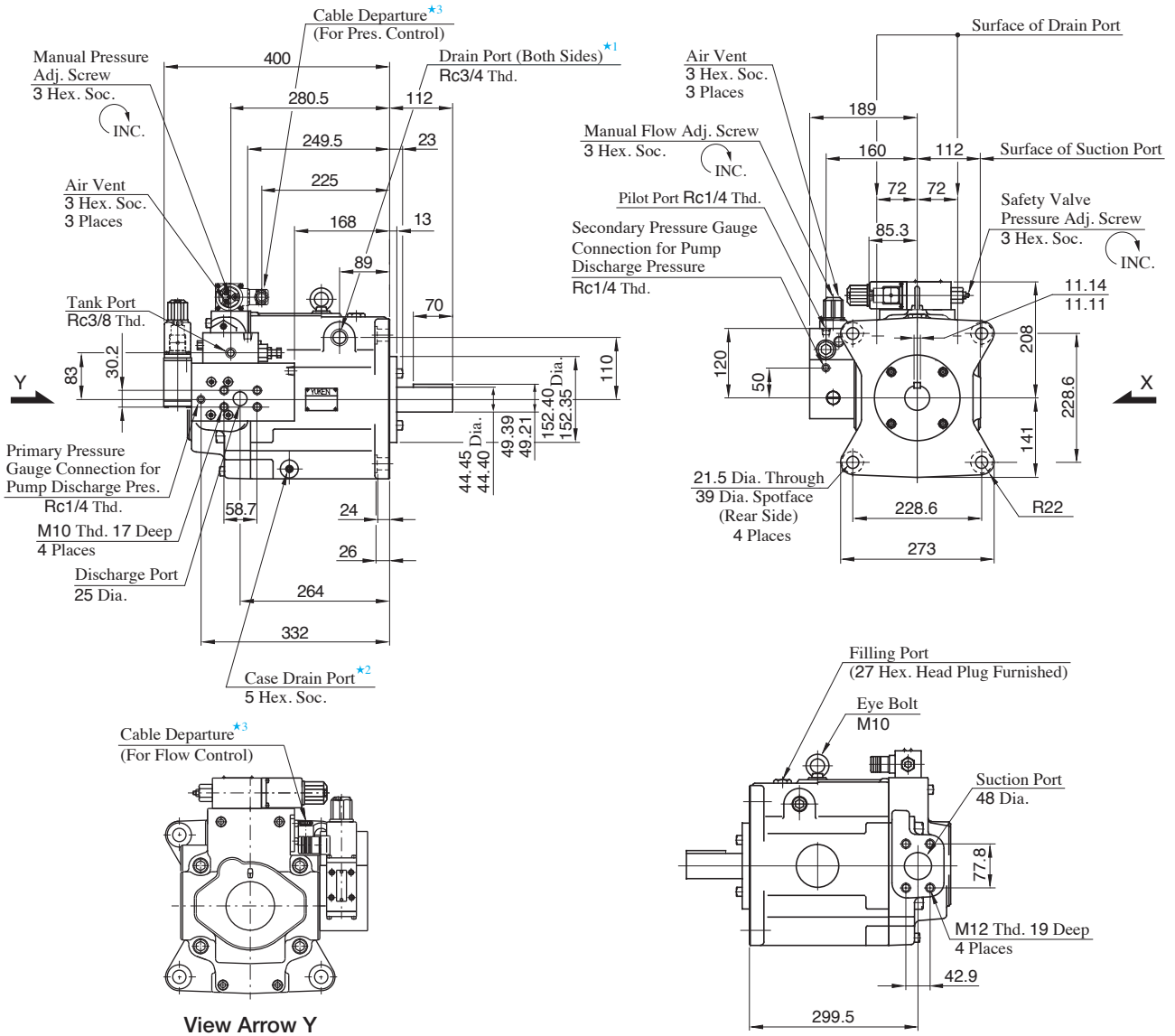

- ★1. Use either port of two drain ports at your option. Keep the remaining port plugged.
- ★2. Case drain port is available for use when draining hydraulic fluid from pump casing.
- ★3. Cable Applicable:
Outside Dia.....8-10 mm
Conductor Area.....Not Exceeding 1.5 mm²

Foot Mtg. : A145-LR04 * S

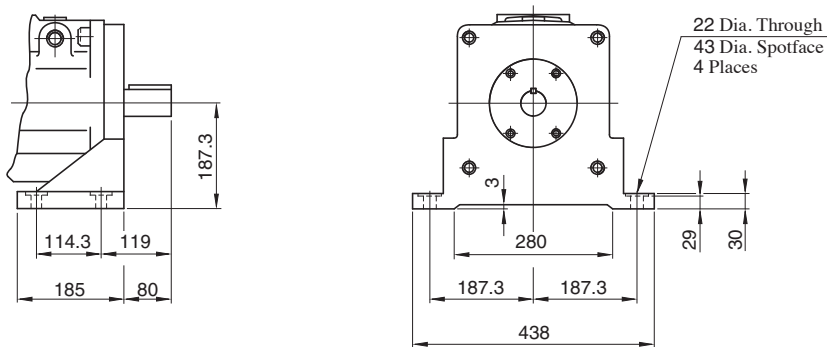

● For other dimensions, refer to "Flange Mtg.".

A Series Variable Displacement Piston Pumps, Electro-Hydraulic Proportional Pressure & Flow Control Type

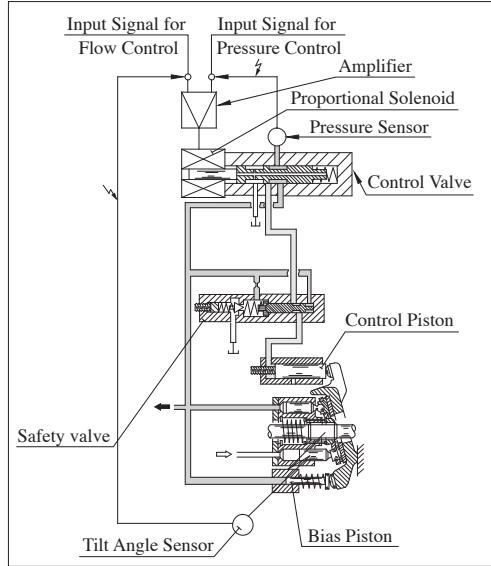
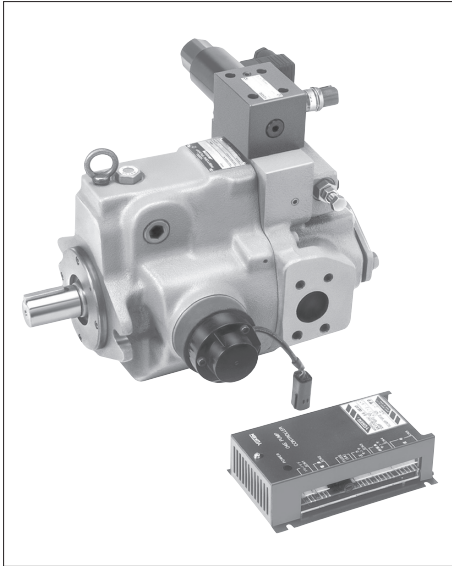

Performance Characteristics

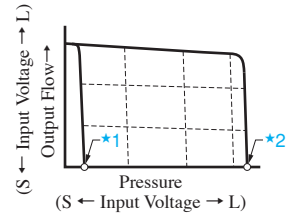

- ★1. Unloading pressure when input signal is 0 V.
- ★2. Safety valve setting pressure

Graphic Symbols

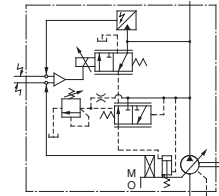

A16/A22/A37/A45/A56

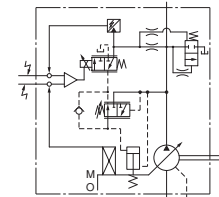

A70/A90/A100/A145

Model Number Designation

Series Number	Mounting	Direction of Rotation	Control Type	Control Pressure at Input Signal is 5 V	Type of Outboard Pump	Port Position	Compensation Number ^{★3}	Design Number
A45 (45.0 cm ³ /rev)	L: Foot Mtg. F: Flange Mtg.	Viewed from Shaft End R: Clockwise ^{★1} (Normal)	04E: Proportional Pressure & Flow Control Type	Use the same measure of the control pressure as shown on the right, 6.9 MPa specify within the range of maximum operating pressure	None ^{★2} A ^{★2} B ^{★2}	None : Axial Port S : Side Port	60	12
A16 (15.8 cm ³ /rev)						—	06	44
A22 (22.2 cm ³ /rev)						—	11	44
A37 (36.9 cm ³ /rev)						—	01	44
A56 (56.2 cm ³ /rev)						—	02	44
A70 (70.0 cm ³ /rev)						—	60	70
A90 (91.0 cm ³ /rev)						—	60	70
A100 (100 cm ³ /rev)						—	60	20
A145 (145 cm ³ /rev)						—	60	62

- ★1. Available to supply pump with anti-clockwise rotation. Consult Yuken for details.
- ★2. These pumps, except A16/A22/A45 types, can be connected to outboard pumps.
 - A37/A56 type (outboard pump connection symbol: **None**): spigot diameter: 82.55 mm (A16, A22, and PV2R1).
 - A70/A90/A100/A145 type (outboard pump connection symbol: **"A"**): spigot diameter: 82.55 mm (A16, A22, and PV2R1).
 - A70/A90/A100/A145 type (outboard pump connection symbol: **"B"**): spigot diameter: 101.6 mm (A37 and PV2R2).
- ★3. Amplifier compensation number may differ according to the main machine conditions. Consult Yuken for details.

Specifications

Descriptions		Model Numbers									
		A16	A22	A37	A45	A56	A70	A90	A100	A145	
Geometric Displacement		cm ³ /rev	15.8	22.2	36.9	45.0	56.2	70.0	91.0	100	145
Operating Pressure	MPa	Rated ^{*2}	16	16	16	16	16	25	25	21	25
		Intermittent ^{*1}	21	16	21	17.2	21	28	28	21	28
Shaft Speed Range		r/min	600 - 1800								
Flow Control	Max. Flow ^{*3}	L/min									
		50 Hz Pin	28.4	40.0	66.4	81.0	101	126	163	180	261
	60 Hz Pin	23.7	33.3	55.4	67.0	84.3	105	136	150	217	
	Min. Pres. Required for Flow Adj. MPa		2								
	Hysteresis		1 % or less								
Repeatability		1 % or less									
Input Signal		Max. Flow / 5 V DC									
Pressure Control	Min. Adjustment Pressure MPa		0.7								
	Hysteresis		1 % or less								
	Repeatability		1 % or less								
	Input Signal		Specified Control Pressure / 5 V DC								
Coil Resistance		Ω (@20°C)	10								
Input Impedance		Flow Control : 10 kΩ Pressure Control : 10 kΩ									
Supply Electric Power		24 V DC (21 - 28 V Included Ripple)									
Power Input (Max.)		W	30								
Output Signal	Flow		5 V DC / Max. Flow (50 Hz Pin)								
	Pressure		5 V DC / Specified Control Pressure								
Alarm Signal Output (Open Collector)		Voltage : Max. 30 V DC Current : Max. 40 mA									
Ambient Temperature		°C	0 - 50 (With Circulated Air)								
Approx. Mass	kg	Flange Mtg.	20.5	20.5	32	32	39	64	76.5	77.5	96.4
		Foot Mtg.	22.7	22.7	36.3	36.3	43.3	76	97	93	121.4

- ★1. Whenever setting pressure, make sure the full cut-off pressure never exceeds the maximum intermittent pressure.
- ★2. When operating the pump exceeding the rated pressure, operating conditions are restricted.
Refer to page A-28 for details.
- ★3. Maximum flow differs to shaft speed.
The value listed above indicates shaft speed of 1800 r/min.
For other shaft speed calculate by the ratio of shaft speed.

Pipe Flange Kits

Pipe flange kits are available. When ordering, specify the kit number from the table below.

Pump Model Numbers	Name of Port	Pipe Flange Kit Numbers		
		Threaded Connection	Socket Welding [★]	Butt Welding
A 16- *R04E	Suction	F5-06-A-10	F5-06-B-10	F5-06-C-10
A 22- *R04E	Discharge	F5-06-A-10	F5-06-B-10	F5-06-C-10
A 37- *R04E	Suction	F5-10-A-10	F5-10-B-10	F5-10-C-10
A 45- *R04E	Discharge	F5-10-A-10	F5-10-B-10	F5-10-C-10
A 56- *R04E				
A 70- *R04E	Suction	F5-12-A-10	F5-12-B-10	F5-12-C-10
	Discharge	F5-08-A-10	F5-08-B-10	F5-08-C-10
A 90- *R04E	Suction	F5-16-A-10	F5-16-B-10	F5-16-C-10
A100- *R04E	Discharge	F5-10-A-10	F5-10-B-10	F5-10-C-10
A145- *R04E				

- ★ In case of using socket welding flanges, there is a case where the operating pressure should be set lower than the normal because of strength of the flanges. Therefore, please pay cautious attention to the operating pressure when the socket welding flanges are used.
- Details of the pipe flange kits are shown on pages A-258 and A-259.

Output Flow vs. Input Signal

● A16

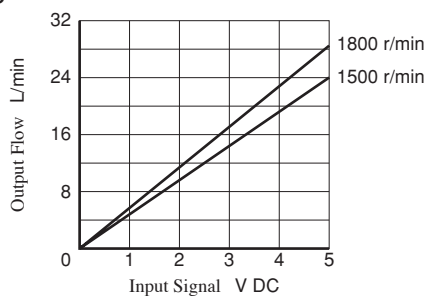

● A56

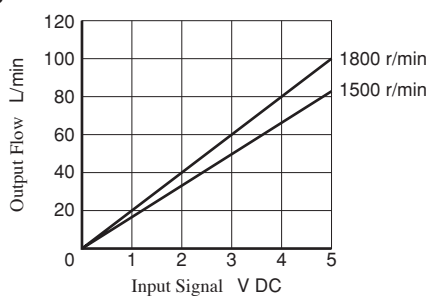

● A22

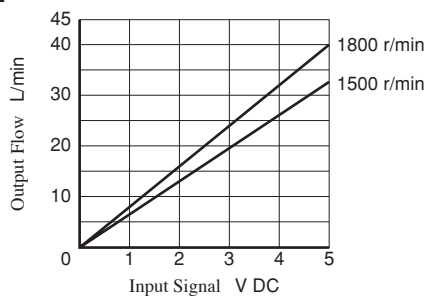

● A70

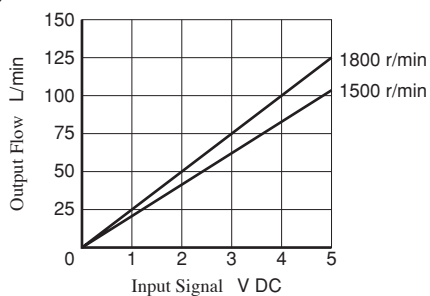

● A37

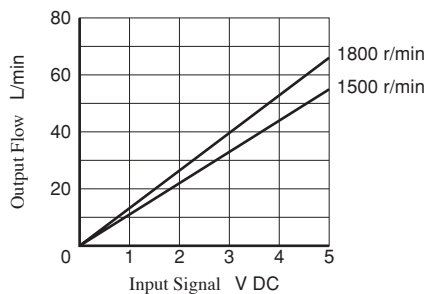

● A90

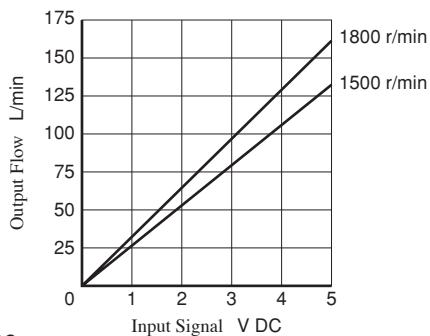

● A45

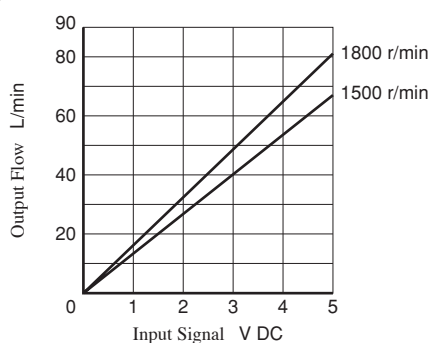

● A100

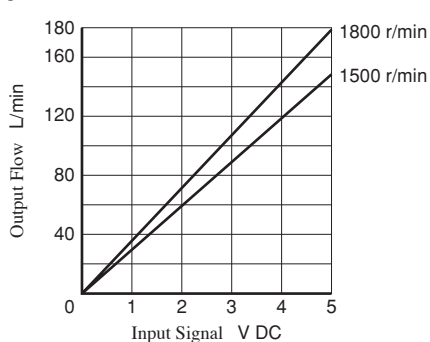

● A145

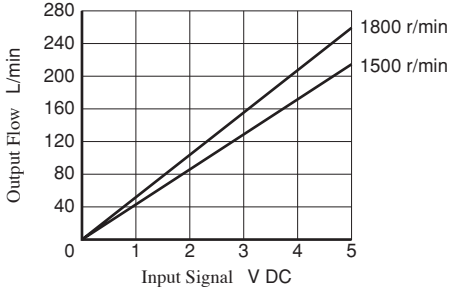

Full Cut-off Pres. vs. Input Signal

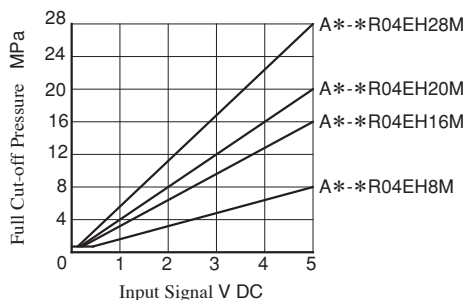

Refer to page A-32 to A-40 for performance characteristics of pressure compensator type excluding characteristics appeared on this catalogue.

Flange Mtg. : A16-FR04E * A22-FR04E *

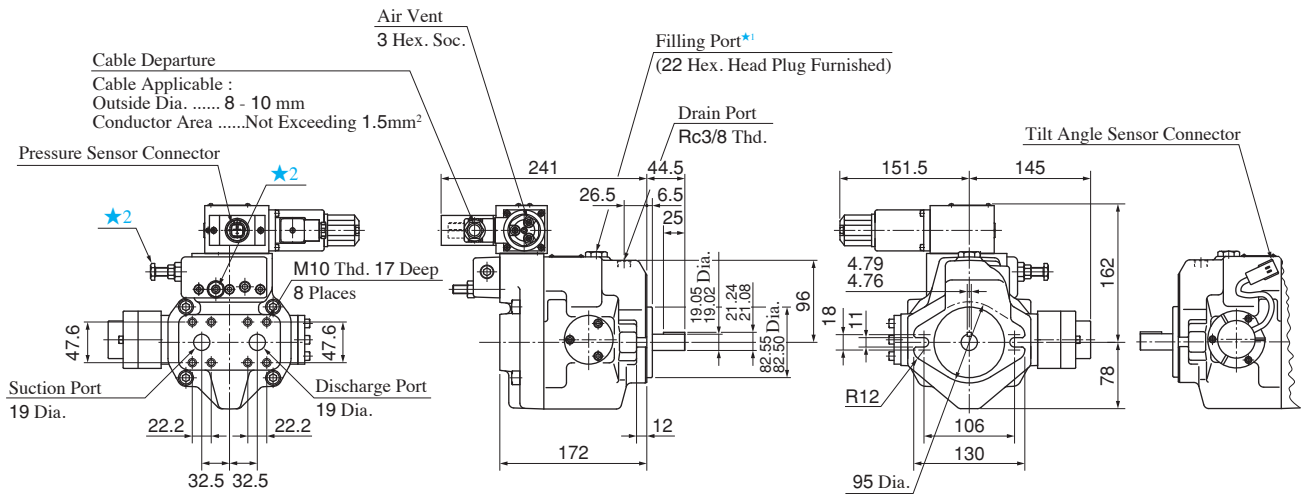

- ★1. Install the pump so that the "Filling Port" is at the top.
- ★2. Do not touch the screw because it is adjusted at the time of shipment.
- ★3. For cable connection with amplifiers, see page A-78.

● Foot Mounting Type

Mounting bracket is common to that of pressure compensator model.
Refer to page A-42 for the dimensions of mounting bracket.

Flange Mtg. : A37-FR04E *

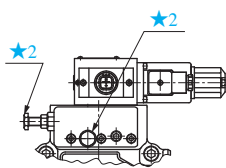
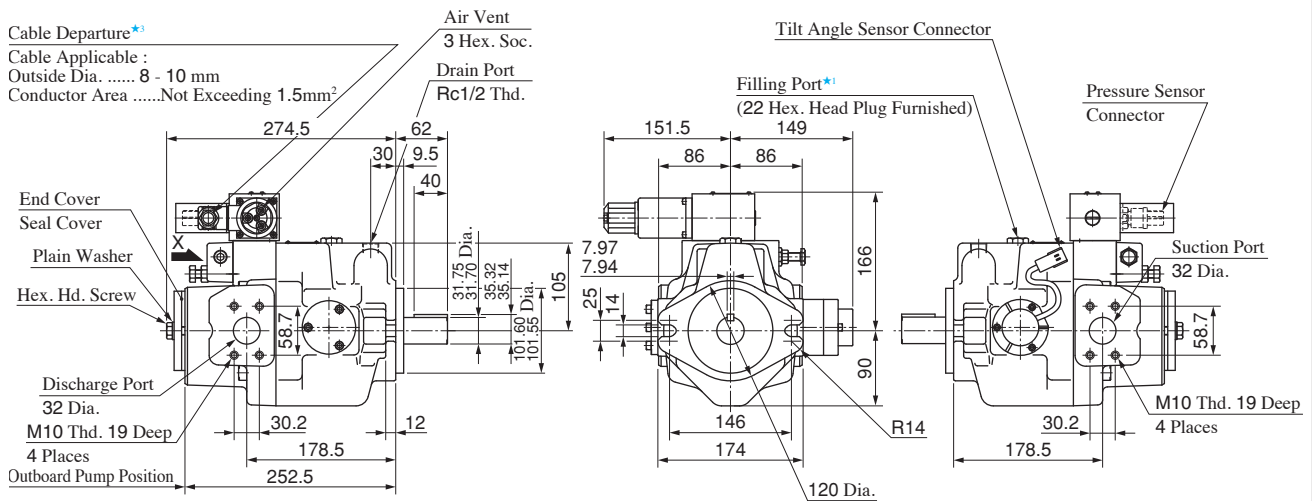

View Arrow X

- ★1. Install the pump so that the "Filling Port" is at the top.
- ★2. Do not touch the screw because it is adjusted at the time of shipment.
- ★3. For cable connection with amplifiers, see page A-78.

● Foot Mounting Type

Mounting bracket is common to that of pressure compensator model.
Refer to page A-43 for the dimensions of mounting bracket.

Axial Port Type

Flange Mtg. : A45-FR04E *

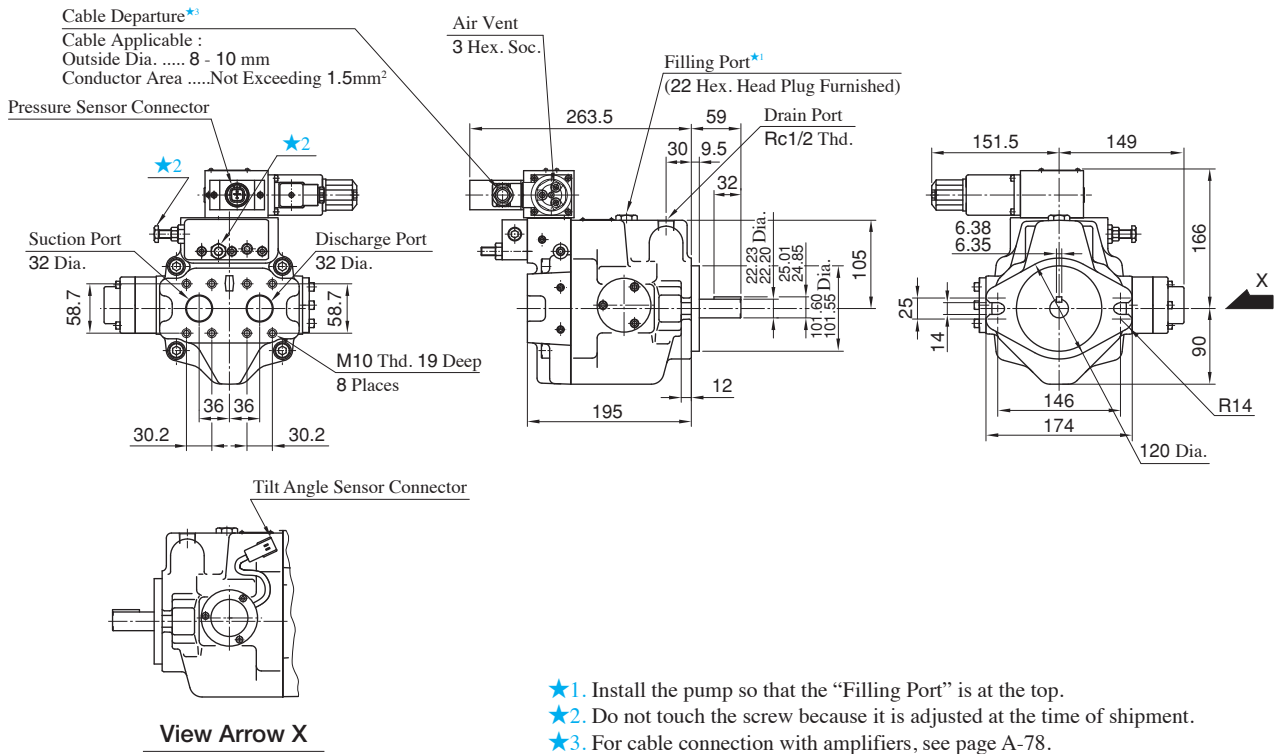

Side Port Type

Flange Mtg. : A45-FR04E * S

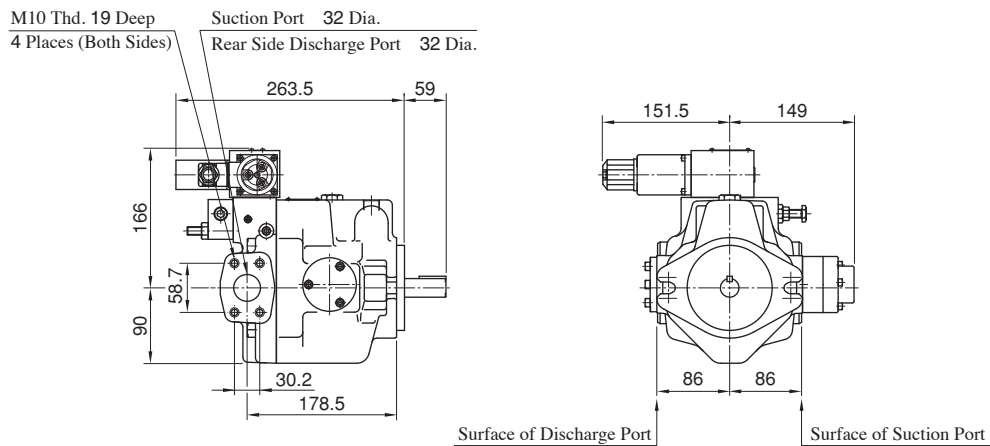

● For other dimensions, refer to “Axial Port Type”.

● **Foot Mounting Type**

Mounting bracket is common to that of pressure compensator model.
 Refer to page A-43 for the dimensions of mounting bracket.

Flange Mtg. : A56-FR04E *

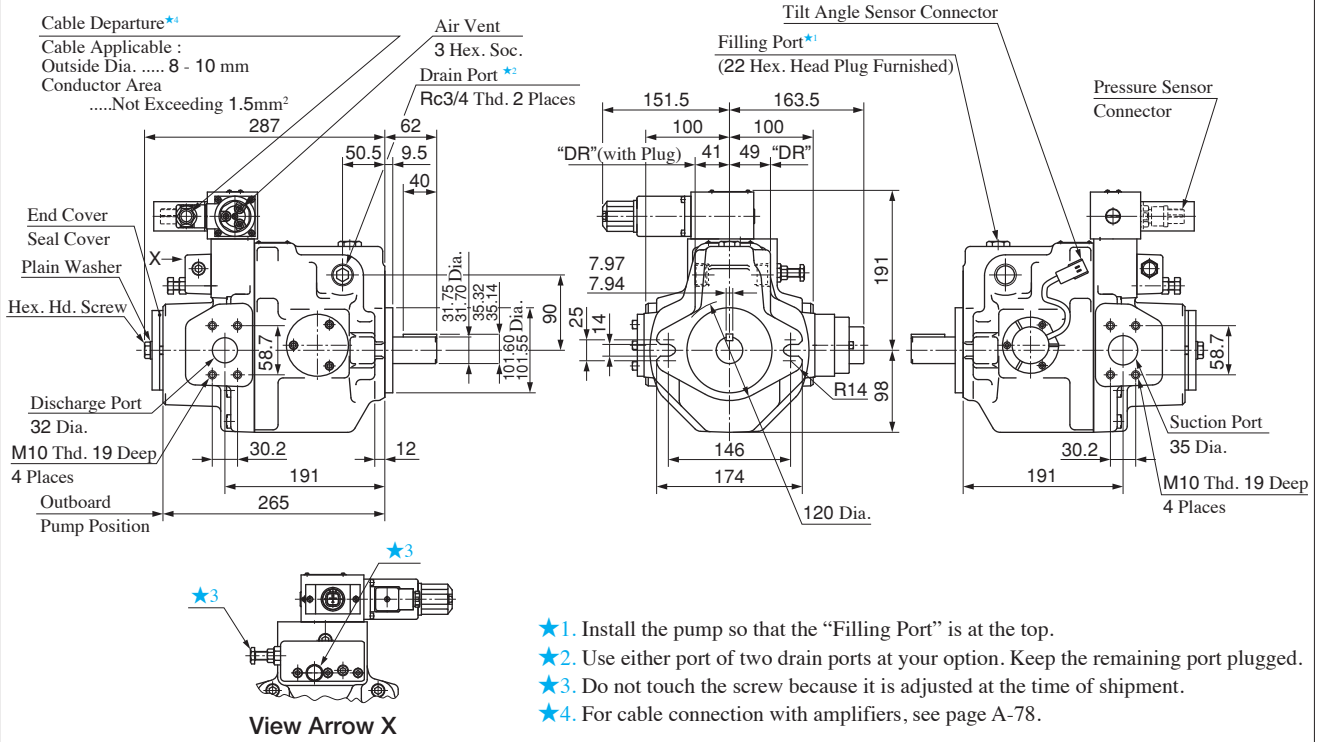

● Foot Mounting Type

Mounting bracket is common to that of pressure compensator model.
 Refer to page A-44 for the dimensions of mounting bracket.

Flange Mtg. : A70-FR04E *

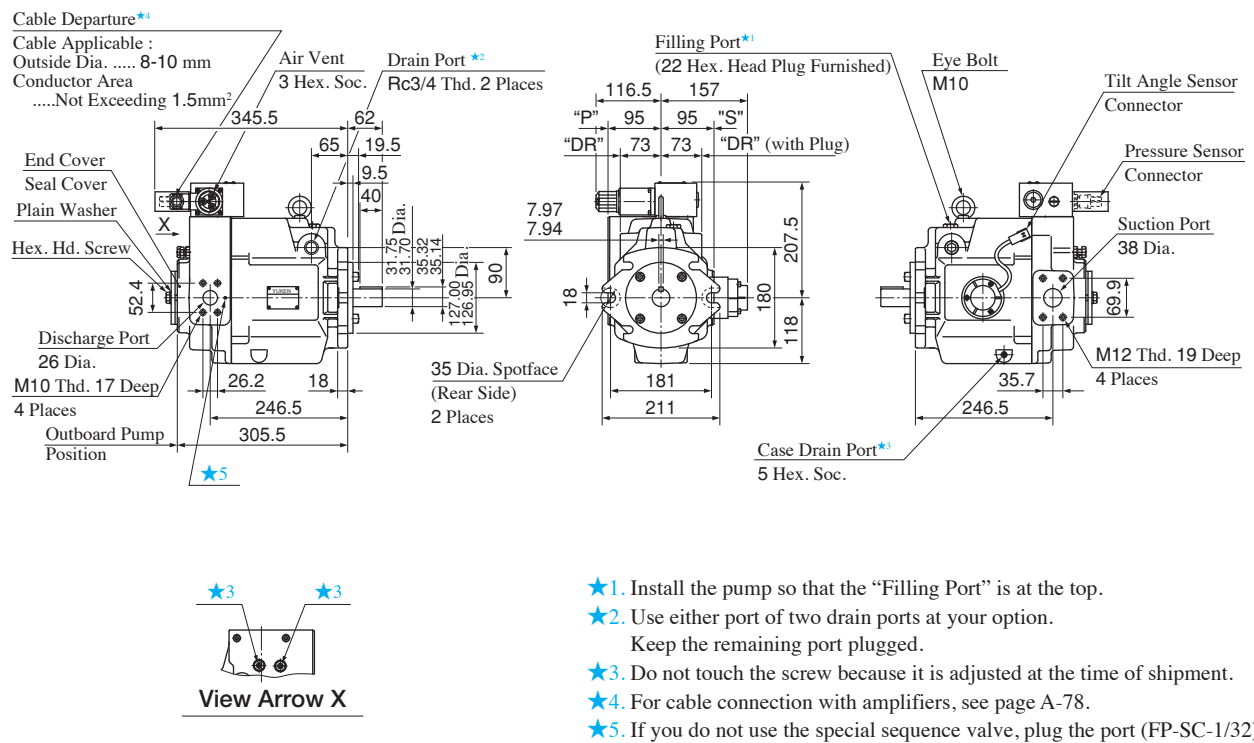

● Foot Mounting Type

Mounting bracket is common to that of pressure compensator model.
 Refer to page A-45 for the dimensions of mounting bracket.

**Flange Mtg. : A90-FR04E **
A100-FR04E ****

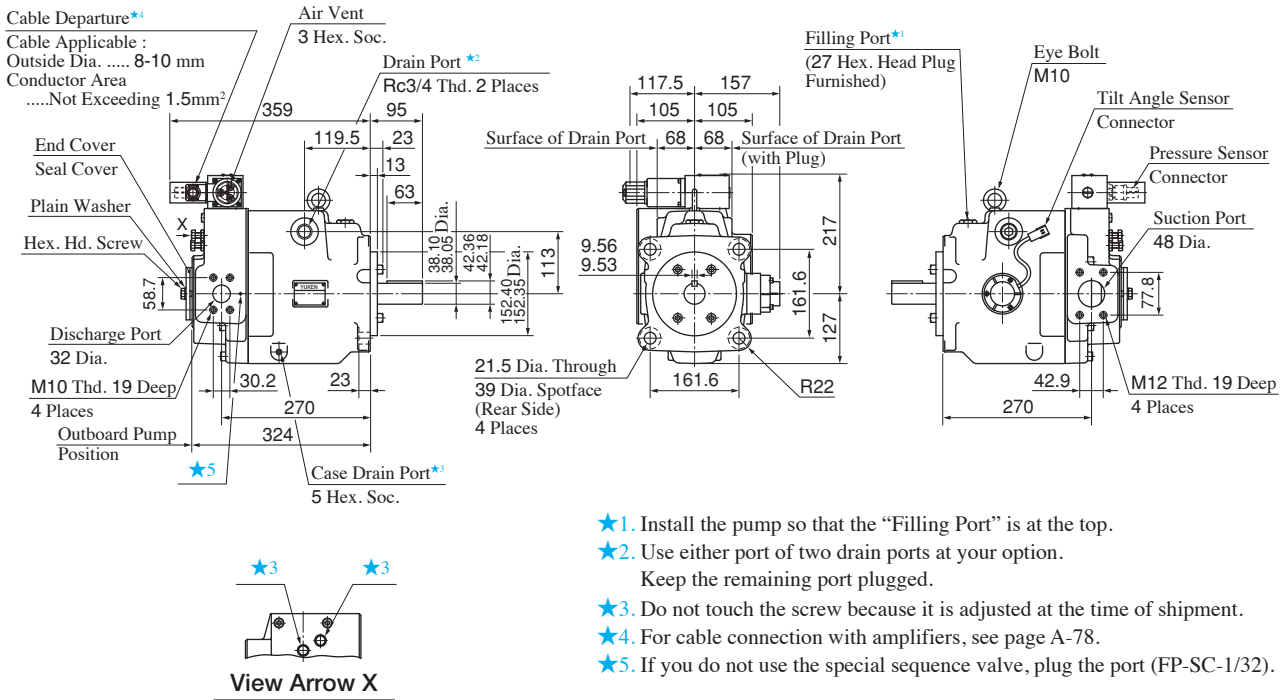

- ★1. Install the pump so that the “Filling Port” is at the top.
- ★2. Use either port of two drain ports at your option. Keep the remaining port plugged.
- ★3. Do not touch the screw because it is adjusted at the time of shipment.
- ★4. For cable connection with amplifiers, see page A-78.
- ★5. If you do not use the special sequence valve, plug the port (FP-SC-1/32).

● **Foot Mounting Type**

Mounting bracket is common to that of pressure compensator model.
Refer to page A-46 for the dimensions of mounting bracket.

Flange Mtg. : A145-FR04E **

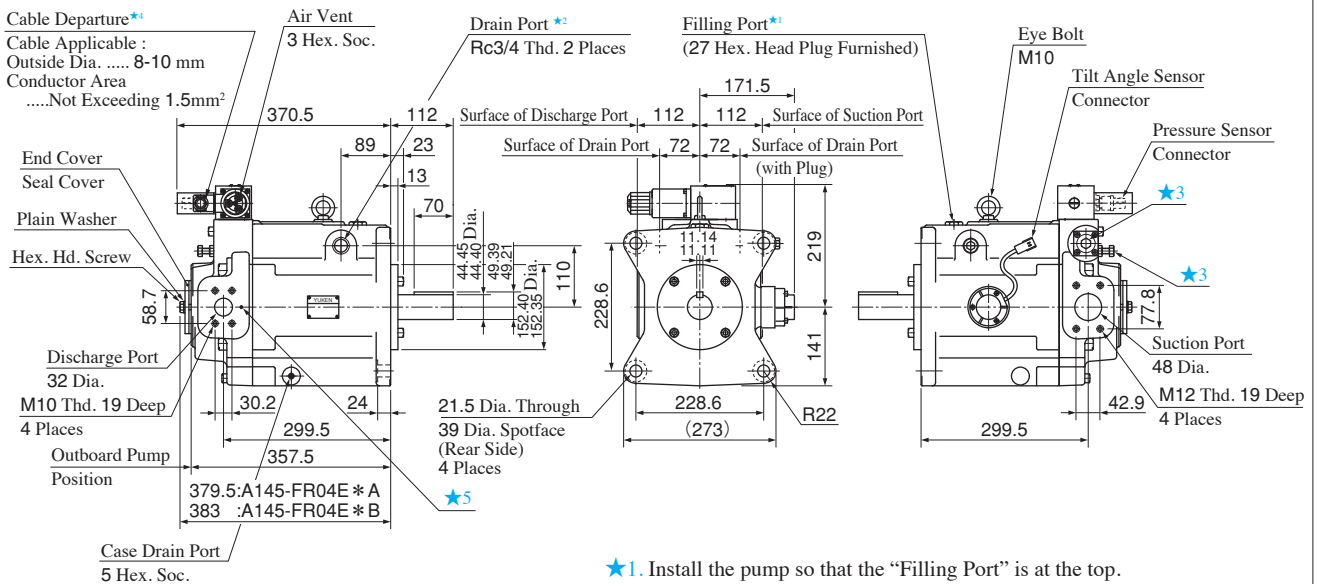

- ★1. Install the pump so that the “Filling Port” is at the top.
- ★2. Use either port of two drain ports at your option. Keep the remaining port plugged.
- ★3. Do not touch the screw because it is adjusted at the time of shipment.
- ★4. For cable connection with amplifiers, see page A-78.
- ★5. If you do not use the special sequence valve, plug the port (FP-SC-1/32).

● **Foot Mounting Type**

Mounting bracket is common to that of pressure compensator model.
Refer to page A-47 for the dimensions of mounting bracket.

Amplifiers for Electro-Hydraulic Proportional Pressure & Flow Control Type Pumps

SK1106-★-*-*-11**

Specifications

Model No.	SK1106-★-*-*-11**
Descriptions	
Applicable Coil Resistance	10 Ω (20°C)
Input Impedance	10 kΩ (PIN, QIN)
Power Supply	24 V DC (21 - 28 V Included Ripple)
Power Input (Max.)	30 W
Input Signal	Max. Flow / 5 V (QIN) Specified Pres. / 5 V (PIN)
Output Signal for Sensor Monitor	5 V / Max. Flow (SMQ) 5 V / Specified Pres. (SMP)
Ambient Temperature	0 - 50 °C
Approx. Mass	450 g

Detail of Connector

Connector	Name of Signal	
CN1 Solenoid	1	Output to pilot valve solenoid
	2	
CN2 Power Supply	1	0 [V] (0 V)
	2	+24 [V] (24 V)
	3	0 [V]
CN3 Pres. Sensor	1	+5 [V] Power Supply for Sensor
	2	0 [V]
	3	Input Signal - Sensor
	4	0 [V]
CN4 Tilt Angle Sensor	1	+8 [V] Power Supply for Sensor
	2	0 [V]
	3	Input Signal - Sensor
	4	0 [V]
	5	—
CN5 Input/Output Signal	1	Input Signal - Flow (Qin)
	2	Input Signal - Common (COM)
	3	Input Signal - Pres. (Pin)
	4	Output Signal - Sensor Monitor P (SMP)
	5	Output Signal - Sensor Monitor Q (SMQ)
	6	0 [V]

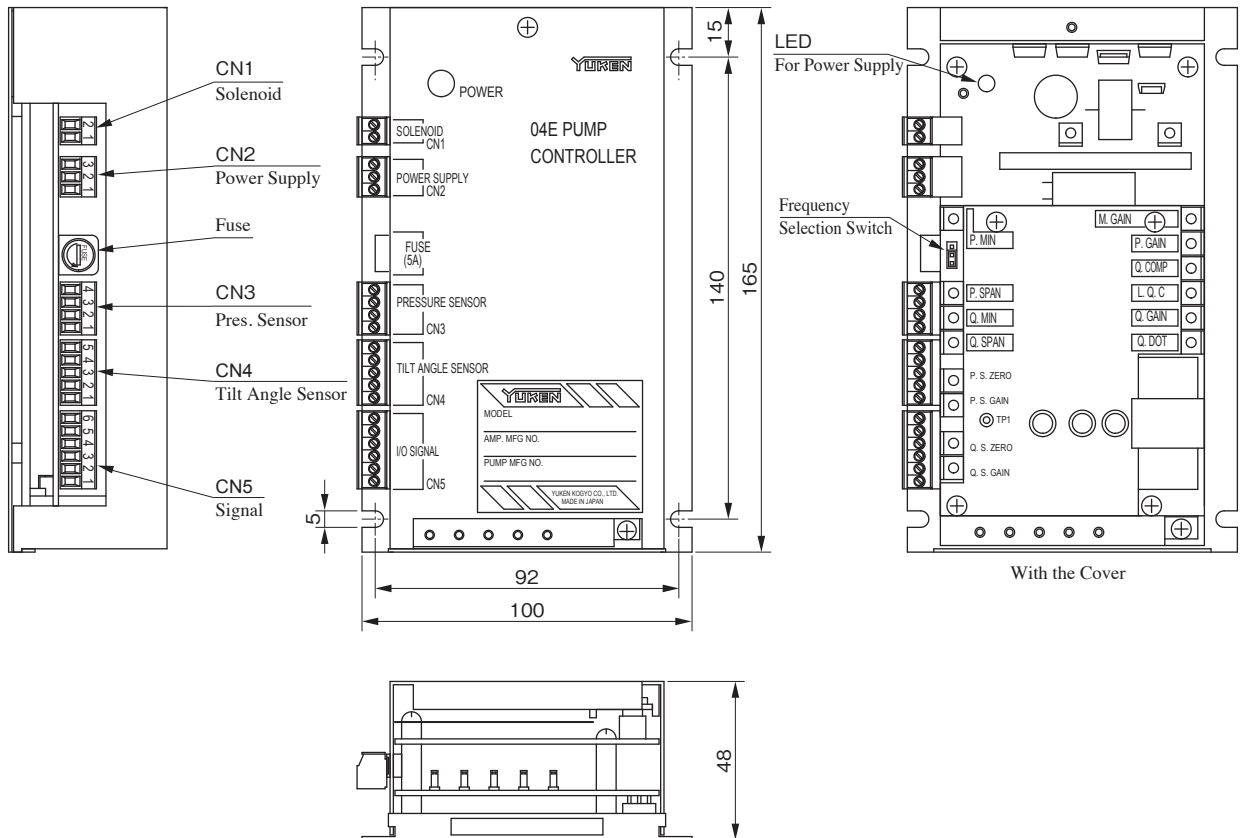

■ Cable Connection Between Pump and Amplifier

The cable connections between the proportional pilot valve and the sensor of the pump and the attached amplifier (SK1106) are shown below.

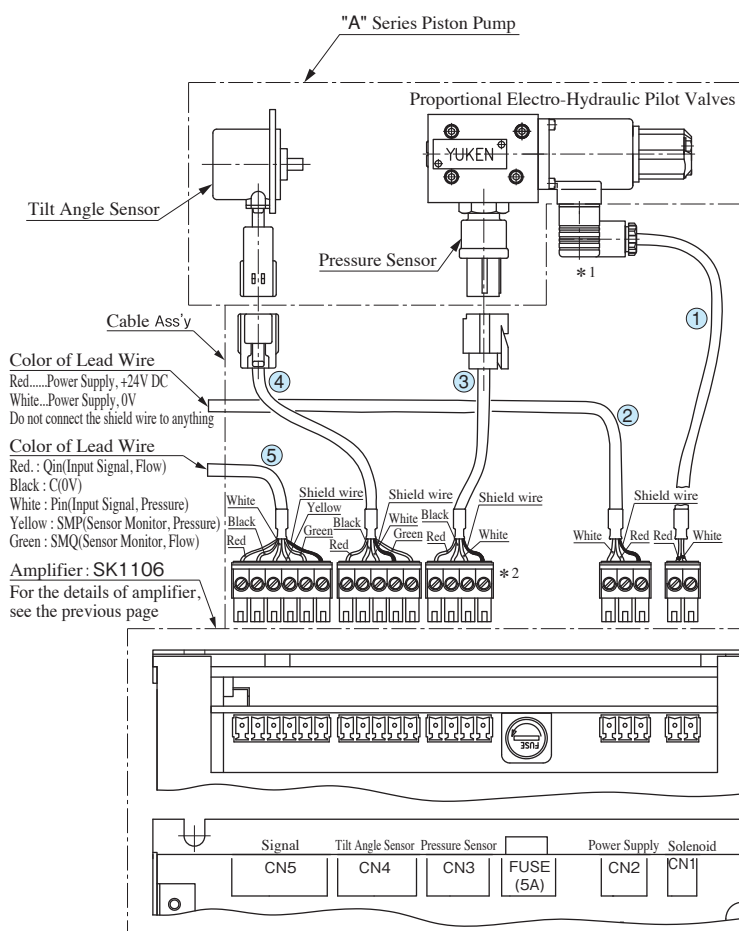

■ Detail of Connector (Pump Side)

1. Pressure Sensor (HW090 connector 3-Pin (T-type) Sumitomo Wiring Systems, Ltd.)



Terminals No.

1. Power Supply (Color of mating connector Ass'y lead : Red)
2. Output(Color of mating connector Ass'y lead : White)
3. 0V(Color of mating connector Ass'y lead : Black)

2. Tilt Angle Sensor (J series connector<Mark II> 4-pin(174259-2) TE connectivity



Terminals No.

1. Power Supply (Color of mating connector Ass'y lead : Red)
2. 0V (Color of mating connector Ass'y lead : Black)
3. Output (Color of mating connector Ass'y lead : White)
4. Shield wire

3. Solenoid (GDM-211-B-11:YUKEN)



Terminals No.

1. SOL Input (Color of mating connector Ass'y Lead : Red)
2. SOL Input (Color of mating connector Ass'y lead : White)
3. Not Used

■ Connector For Cable Ass'y

● Amplifier Side

MC1.5/*-ST-3.81
 (Phoenix Contact)

● Sensor Side

1. Pressure Sensor
 Type:HW090
 Housing : F (6189-0131)
 Retainer : F (6918-0326)
 Terminal : F (1500-0106)
 Wire seal : S (7165-0118)
 (Sumitomo Wiring Systems, Ltd.)

2. Tilt Angle Sensor
 Type : J Series
 Connector<Mark II>
 4-pin : (174257-2)
 (TE connectivity)

★1. Cable assemblies are available. When ordering, specify the cable Ass'y model numbers from the table below.

Name of Cable Ass'y	Cable Ass'y Model Numbers					
	Approx. Length of Cable (mm)					
	2000	5000	10000	15000	20000	25000
①For Solenoid	SK1112-S-2-11	SK1112-S-5-11	SK1112-S-10-11	SK1112-S-15-11	SK1112-S-20-11	SK1112-S-25-11
②For Power Supply	SK1112-V-2-11	SK1112-V-5-11	SK1112-V-10-11	SK1112-V-15-11	SK1112-V-20-11	SK1112-V-25-11
③For Pressure Sensor	SK1112-P-2-11	SK1112-P-5-11	SK1112-P-10-11	SK1112-P-15-11	SK1112-P-20-11	SK1112-P-25-11
④For Tilt Angle Sensor	SK1112-Q-2-11	SK1112-Q-5-11	SK1112-Q-10-11	SK1112-Q-15-11	SK1112-Q-20-11	SK1112-Q-25-11
⑤For Signal	SK1112-C-2-11	SK1112-C-5-11	SK1112-C-10-11	SK1112-C-15-11	SK1112-C-20-11	SK1112-C-25-11

★2. *1 connector for the solenoid (GDM-211-B-11) and *2 connectors for amplifier (MC1.5/*-ST-3.81) are already attached to the pump and the amplifier, respectively. If using the cable Ass'y, remove every attached connector before wiring.

Series Variable Displacement Piston Pumps, "OBE" Type Electro-Hydraulic Proportional Pressure & Flow Control Type

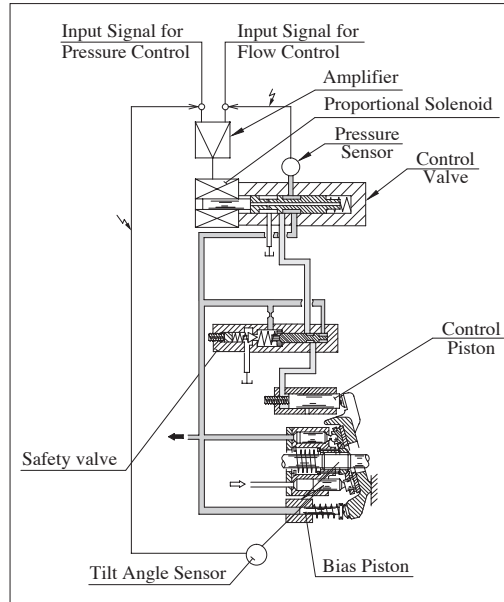
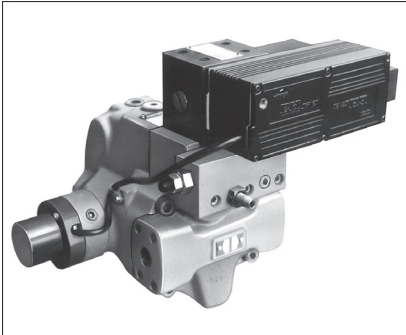

Performance Characteristics

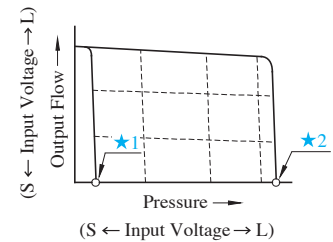

- ★1. Unloading pressure when input signal is 0 V.
- ★2. Safety valve setting pressure

Graphic Symbols

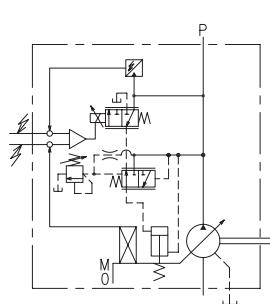

A16/A22/A37/A56

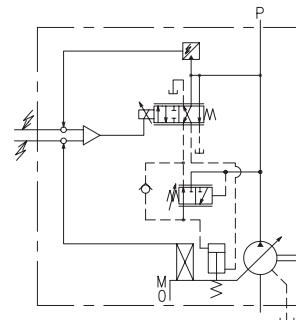

A70/A90/A145

Model Number Designation

A70	-F	R	04EH	16M	R	S	-60	44
Series Number	Mounting	Direction of Rotation	Control Type	Pressure Control Level	Amplifier Direction	Port Position	Compensation Number ^{★2}	Design Number
A16 (15.8 cm ³ /rev)	F: Flange Mtg.	(Viewed from Shaft End)	04EH: "OBE" Type Proportional Pressure & Flow Control Type	Specify Control Pressure between 6.9 MPa and Maximum Operating Pressure (Example) 16M:16 MPa	—	None: Axial Port S: Side Port	06	44
A22 (22.2 cm ³ /rev)							11	44
A37 (36.9 cm ³ /rev)							01	44
A56 (56.2 cm ³ /rev)							02	44
A70 (70.0 cm ³ /rev)	L: Foot Mtg.	R: Clockwise ^{★1} (Normal)			(Viewed from Shaft End) R: Right L: Left	S: Side Port	60	70
A90 (91.0 cm ³ /rev)							60	70
A145 (145 cm ³ /rev)							60	62

★1. Available to supply pump with anti-clockwise rotation. Consult Yuken for details.
 ★2. Amplifier Compensation Number may differ according to the main machine conditions. Consult Yuken for details.

Specifications

Descriptions		Model Numbers							
		A16	A22	A37	A56	A70	A90	A145	
Geometric Displacement		cm ³ /rev	15.8	22.2	36.9	56.2	70.0	91.0	145.0
Operating Pressure	MPa	Rated ^{★2}	16	16	16	16	25	25	25
		Intermittent ^{★1}	21	16	21	21	28	28	28
Shaft Speed Range		r/min	600 - 1800						
Flow Control	Max. Flow ^{★2}	L/min	28.4	40.0	66.4	101.2	126.0	163.0	261.0
	Min. Pres. Required for Flow Adj.	MPa	2.0						
	Hysteresis		1 % or less						
	Repeatability		1 % or less						
	Input Signal		Max. Flow / 5 V DC						
Pressure Control	Min. Adjustment Pressure	MPa	0.7						
	Hysteresis		1 % or less						
	Repeatability		1 % or less						
	Input Signal		Specified Control Pressure / 5 V DC						
Coil Resistance		Ω [@ 20°C]	10						
Input Impedance			Flow Control : 10 kΩ Pres. Control : 10 kΩ						
Supply Electric Power			24 V DC (21 - 28 V Included Ripple)						
Power Input (Max.)		W	30						
Output Signal	Flow		5 V DC / Max. Flow						
	Pressure		5 V DC / Specified Control Pressure						
Alarm Signal Output (Open Collector)			Voltage : Max. 30 V DC Current : Max. 40 mA						
Ambient Temperature		°C	0 - 50 (With Circulated Air)						
Mass	kg	Flange Mtg.	20.7	20.7	32.2	39.2	64	76.5	98
		Foot Mtg.	22.9	22.9	36.5	43.5	76	97	123

★1. Whenever setting pressure, make sure the full cut-off pressure never exceeds the maximum intermittent pressure.

★2. When operating the pump exceeding the rated pressure, operating conditions are restricted.
Refer to page A-28 for details.

★3. Maximum flow differs to shaft speed.
The value listed above indicates shaft speed of 1800 r/min.
For other shaft speed calculate by the ratio of shaft speed.

Pipe Flange Kits

For pipe flange, refer to form of pressure compensator type on page A-29.

Output Flow vs. Input Signal

● A16

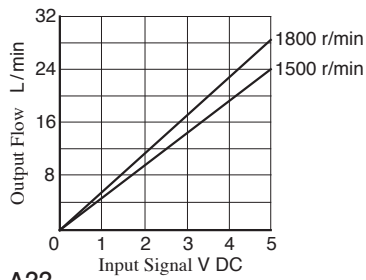

● A56

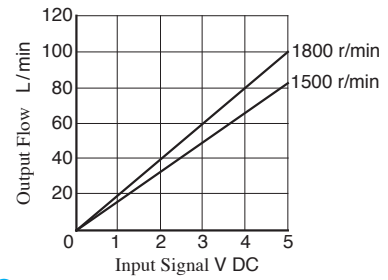

● A22

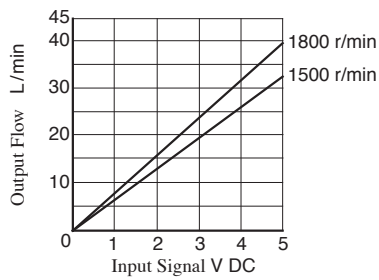

● A70

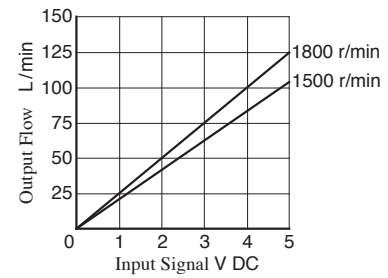

● A37

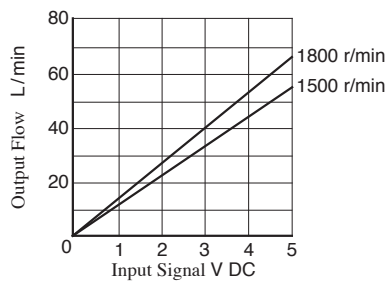

● A90

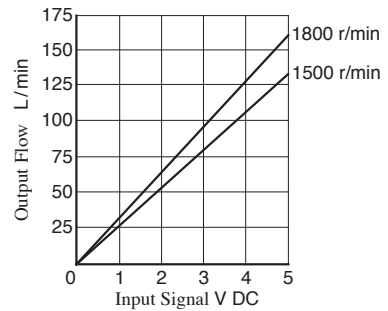

● A145

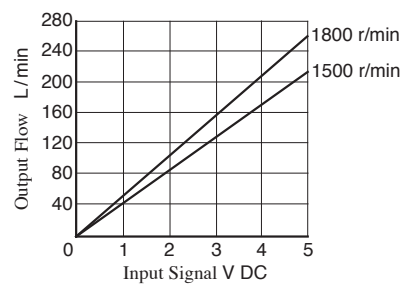

Full Cut-off Pres. vs. Input Signal

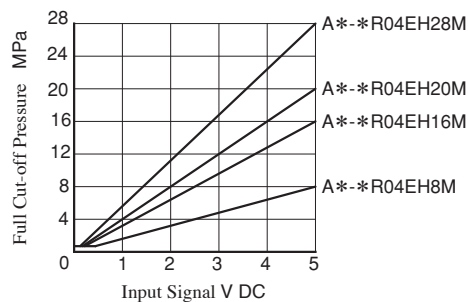

Refer to pages A-32 to A-34, A-36 to A-38 and A-40 for performance characteristics of pressure compensator type excluding characteristics appeared on this catalogue.

Axial Port Type

**Flange Mtg. : A16-FR04EH *
A22-FR04EH ***

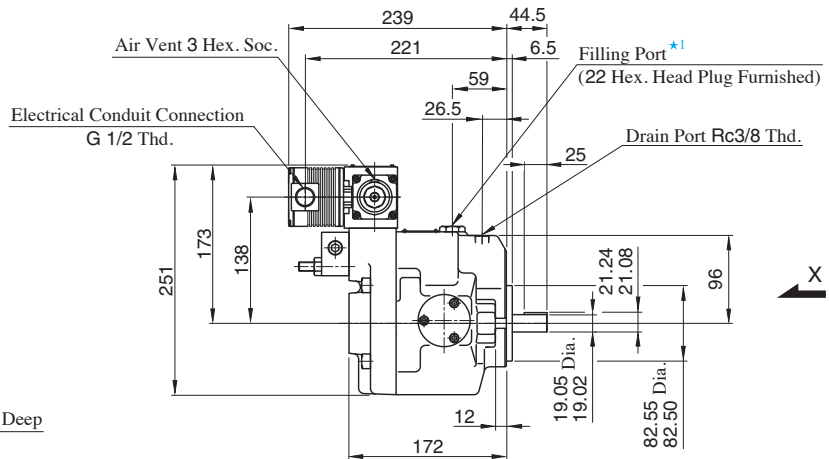
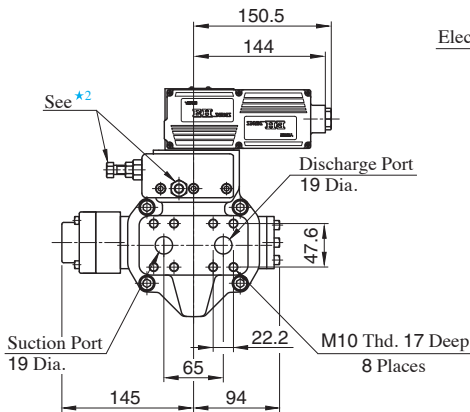

- ★1. Install the pump so that the "Filling Port" is at the top.
- ★2. Do not touch the screw because it is adjusted at the time of shipment.
- ★3. For detail of amplifier, refer to page A-87.

● Side Port Type

Port mounting dimensions are the same as those of pressure compensator model. Refer to page A-42 for port mounting dimensions.

● Foot Mounting Type

Mounting bracket is common to that of pressure compensator model. Refer to page A-42 for the dimensions of mounting bracket.

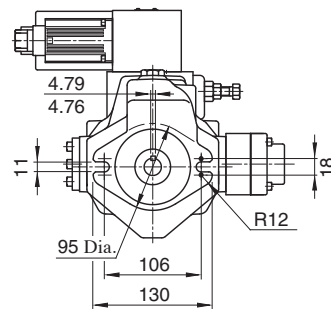

View Arrow X

Axial Port Type

Flange Mtg. : A37-FR04EH *

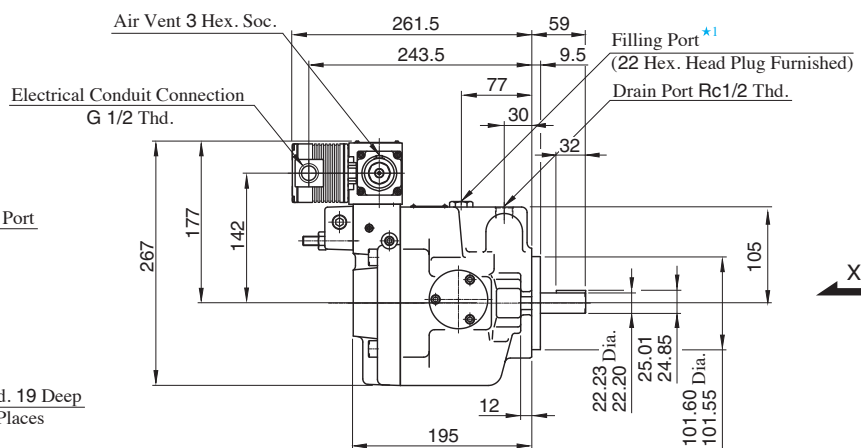
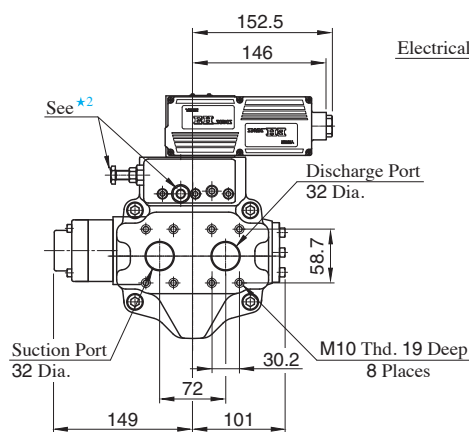

- ★1. Install the pump so that the "Filling Port" is at the top.
- ★2. Do not touch the screw because it is adjusted at the time of shipment.
- ★3. For detail of amplifier, refer to page A-87.

● Side Port Type

Port mounting dimensions are the same as those of pressure compensator model. Refer to page A-43 for port mounting dimensions.

● Foot Mounting Type

Mounting bracket is common to that of pressure compensator model. Refer to page A-43 for the dimensions of mounting bracket.

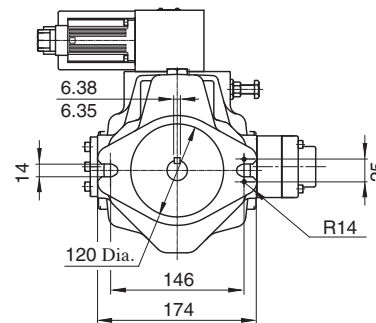

View Arrow X

Axial Port Type

Flange Mtg. : A56-FR04EH *

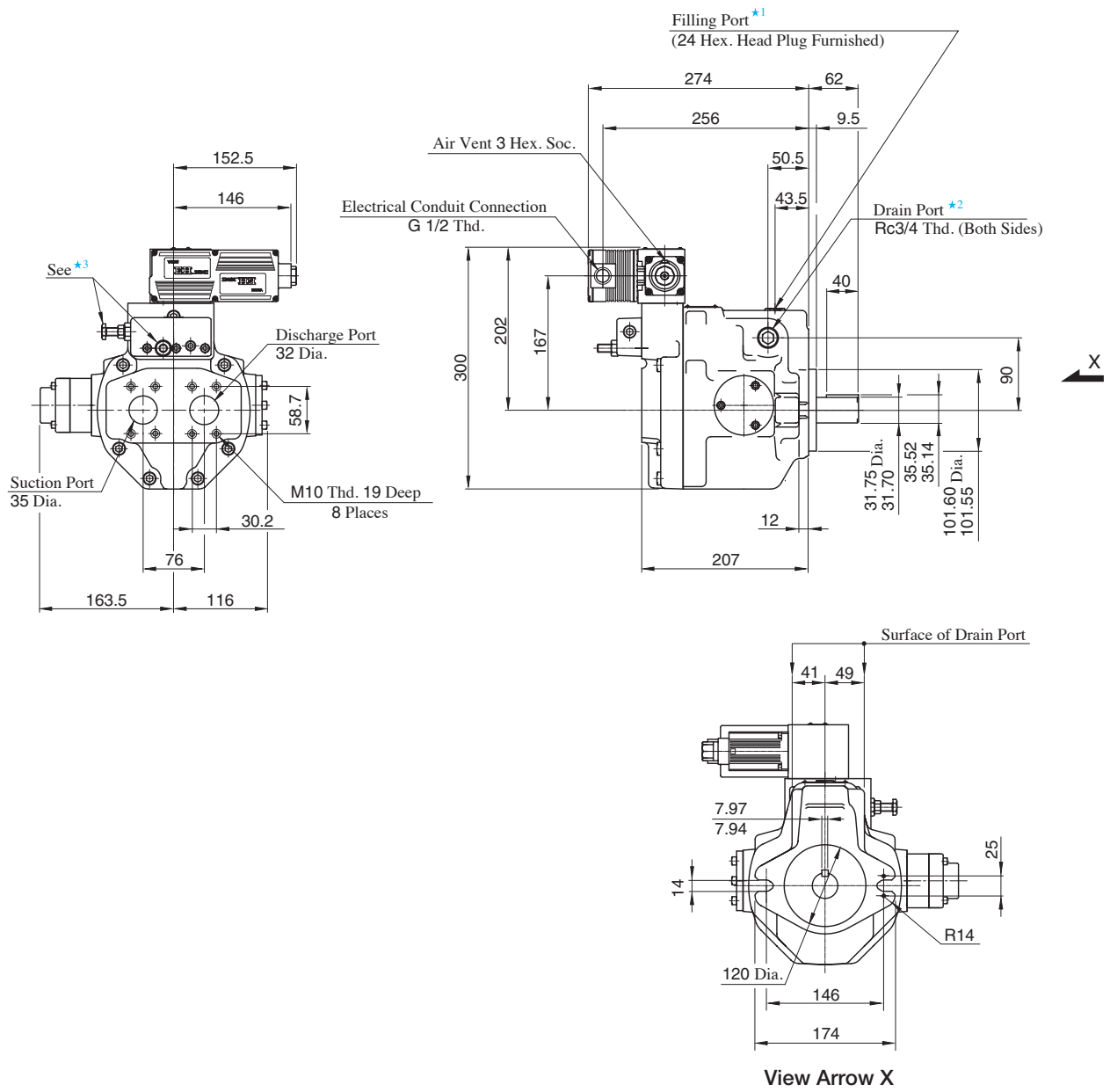

- ★1. Install the pump so that the "Filling Port" is at the top.
- ★2. Use either port of two drain ports at your option. Keep the remaining port plugged.
- ★3. Do not touch the screw because it is adjusted at the time of shipment.
- ★4. For detail of amplifier, refer to page A-87.

● Side Port Type

Port mounting dimensions are the same as those of pressure compensator model. Refer to page A-44 for port mounting dimensions.

● Foot Mounting Type

Mounting bracket is common to that of pressure compensator model. Refer to page A-44 for the dimensions of mounting bracket.

Flange Mtg.

◦ Amplifier Direction "L" : A70-FR04EH *LS

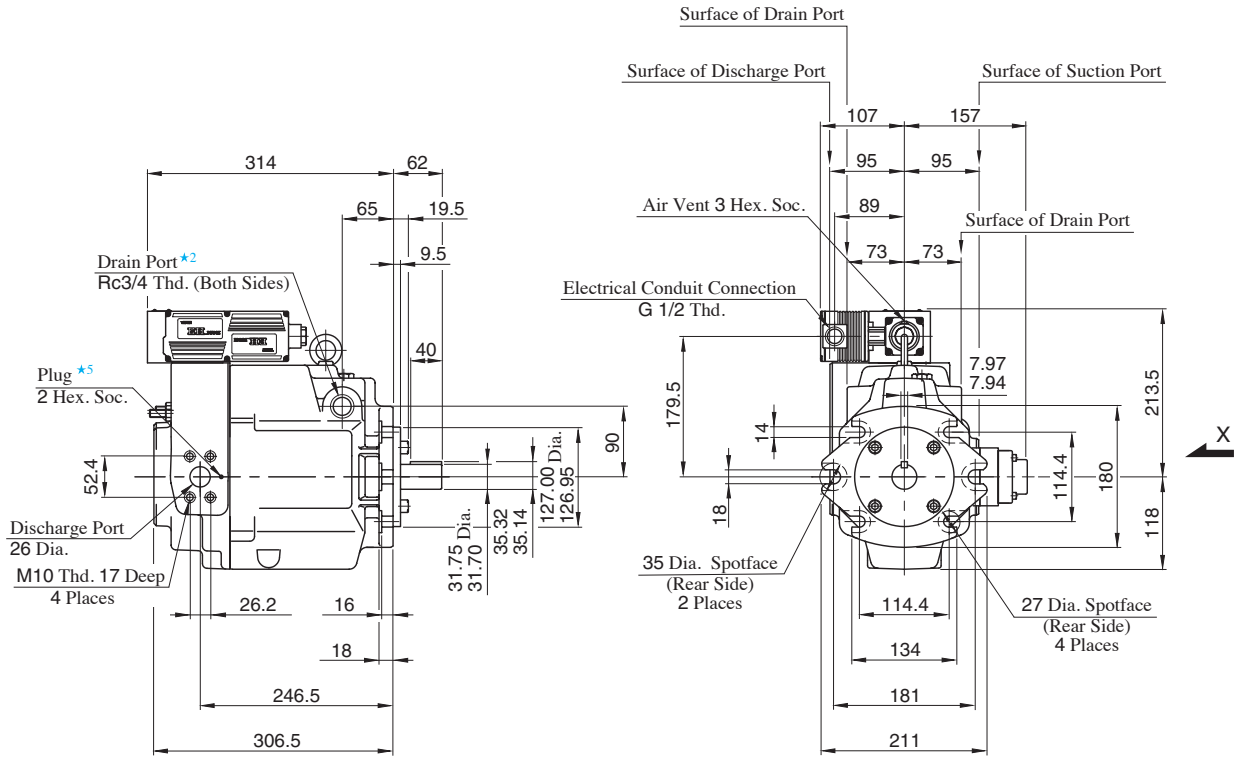

◦ Amplifier Direction "R": A70-FR04EH *RS

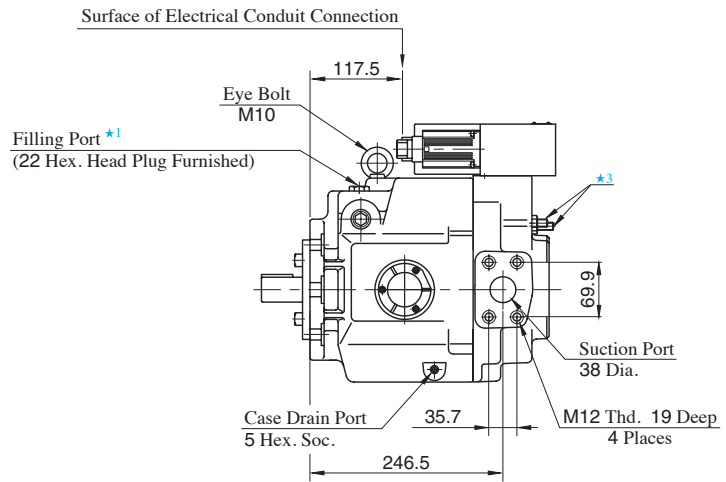
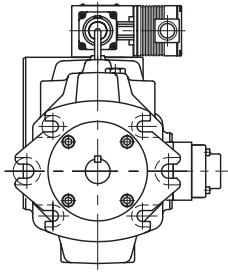

View Arrow X

- ★1. Install the pump so that the "Filling Port" is at the top.
- ★2. Use either port of two drain ports at your option. Keep the remaining port plugged.
- ★3. Do not touch the screw because it is adjusted at the time of shipment.
- ★4. For detail of amplifier, refer to page A-87.
- ★5. If you use the special sequence valve, remove the plug.

● Foot Mounting Type

Mounting bracket is common to that of pressure compensator model.
Refer to page A-45 for the dimensions of mounting bracket.

Flange Mtg.

- Amplifier Direction "L" : A90-FR04EH *LS

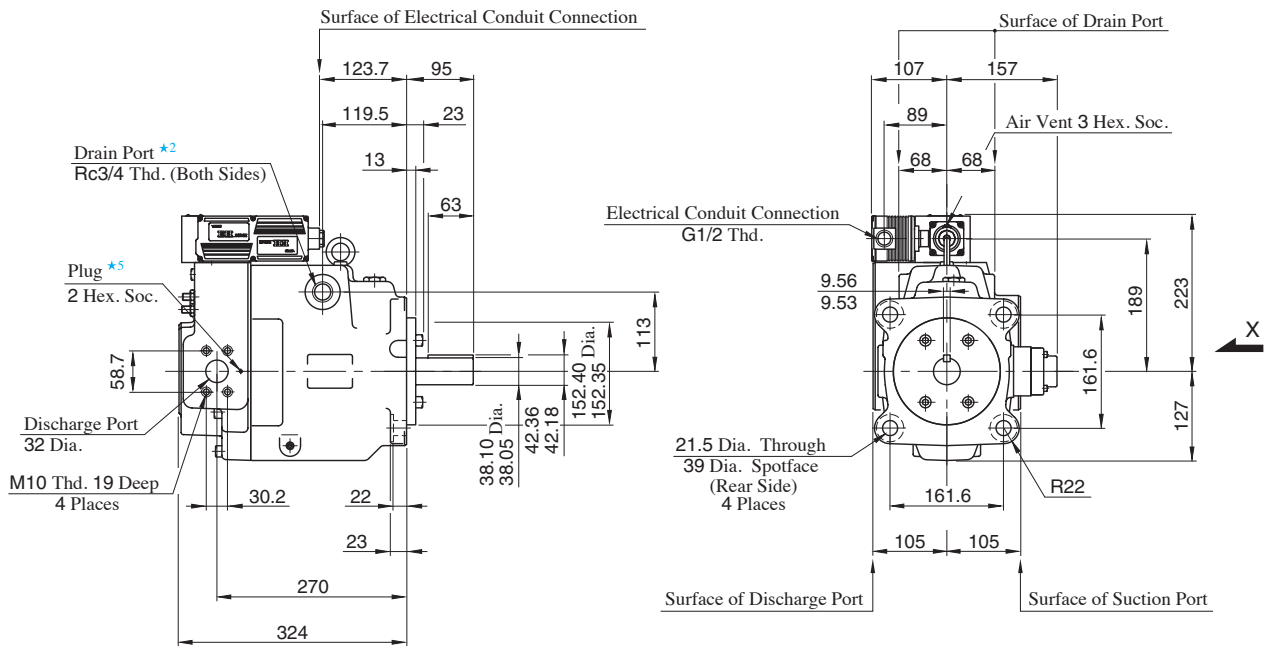

- Amplifier Direction "R": A90-FR04EH *RS

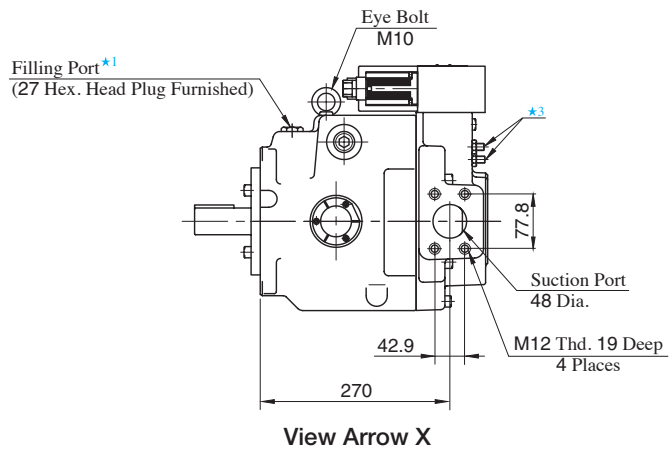
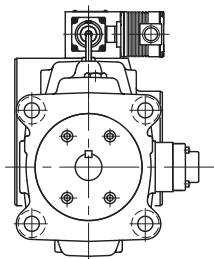

- ★1. Install the pump so that the "Filling Port" is at the top.
- ★2. Use either port of two drain ports at your option. Keep the remaining port plugged.
- ★3. Do not touch the screw because it is adjusted at the time of shipment.
- ★4. For detail of amplifier, refer to page A-87.
- ★5. If you use the special sequence valve, remove the plug.

● Foot Mounting Type

Mounting bracket is common to that of pressure compensator model.
Refer to page A-46 for the dimensions of mounting bracket.



Flange Mtg.

◦ Amplifier Direction "L" : A145-FR04EH *LS

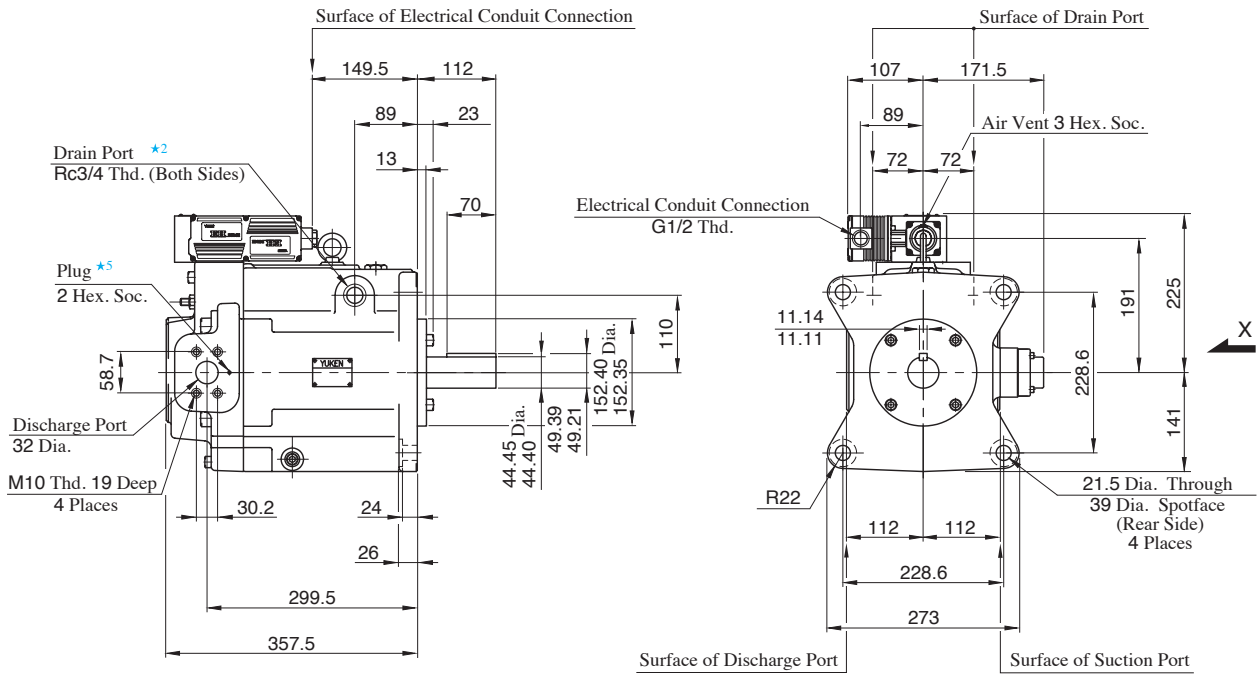

◦ Amplifier Direction "R": A145-FR04EH *RS

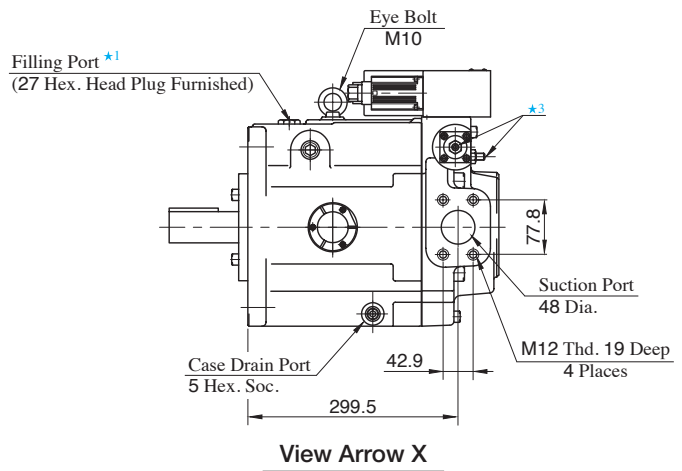
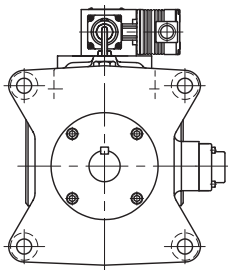

- ★1. Install the pump so that the "Filling Port" is at the top.
- ★2. Use either port of two drain ports at your option. Keep the remaining port plugged.
- ★3. Do not touch the screw because it is adjusted at the time of shipment.
- ★4. For detail of amplifier, refer to page A-87.
- ★5. If you use the special sequence valve, remove the plug.

● Foot Mounting Type

Mounting bracket is common to that of pressure compensator model.
Refer to page A-47 for the dimensions of mounting bracket.

- Detail of Amplifier
- Connecting Terminal

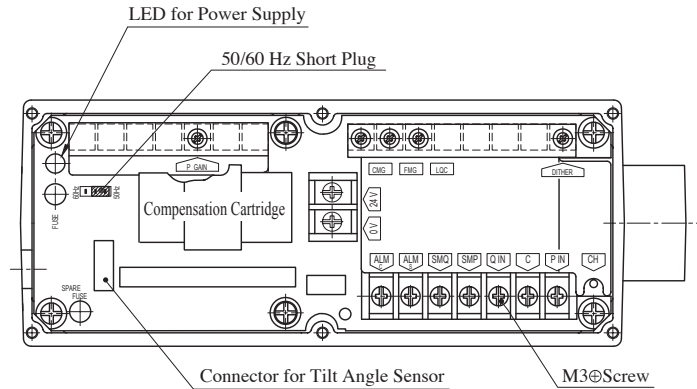

Terminal	Name
P IN	Input Signal, Pressure (+)
C	Input Signal (COM)
Q IN	Input Signal, Flow (+)
SMP	Sensor Monitor Output, Pressure
SMQ	Sensor Monitor Output, Tilt Angle
0 V	Power Supply
24 V	
ALM S	Alarm Output
ALM C	Alarm Output (COM)
CH	Output Current Check (to COM)

- Note 1. For "SENSOR MONITOR" terminal, external instruments should have input impedance of more than 10 kΩ.
2. For "CH" terminal, external instruments should have input impedance of more than 10 kΩ.
3. Volume adjustment of "DITHER", "GAIN", "CMG", "FMG" and "LQC" is made at the time of shipment. Adjustment at the customer is not required.
4. Use shielded cable for "Input" connection. The ground of the shielded cable must be connected to input signal side.

- Circuit Schematic

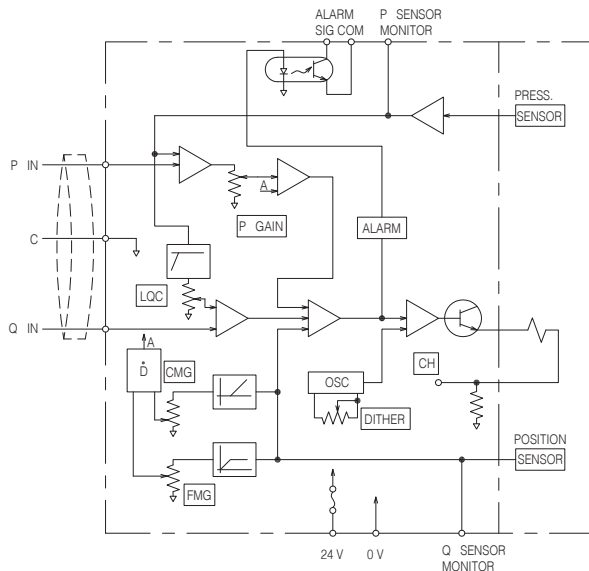

A Series Variable Displacement Piston Pumps, Two-Pressure Two-Flow Control Type By System Pressure

Graphic Symbol

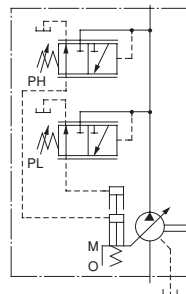

■ Performance Characteristics

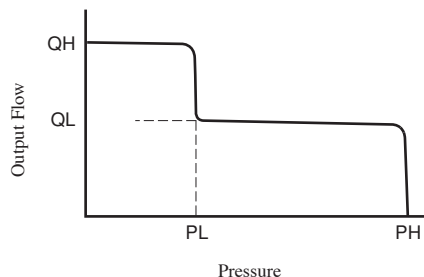

■ Specifications

Model Numbers	Geometric Displacement cm ³ /rev	Delivery Volume Adj. Range cm ³ /rev		Operating Pressure MPa		Shaft Speed Range r/min	
		Large Displacement (QH)	Small Displacement (QL)	Rated	Intermittent	Max.	Min.
A16- * -R-05- * * -S-K-32	15.8	2.6-15.8	2.6-11.1	16	21	1800	600
A37- * -R-05- * * -S-K-32	36.9	4.1-36.9	4.1-20.1	16	21		
A56- * -R-05- * * -S-K-32	56.2	3.4-56.2	3.4-25.1	16	21		

■ Model Number Designation

A16	-F	-R	-05	-B	C	-S	-K	-32
Series Number	Mounting	Direction of Rotation	Control Type	Pres. Adj. Range for High Pressure MPa	Pres. Adj. Range for Low Pressure MPa	Port Position	Shaft Extension	Design Number
A16 (15.8 cm ³ /rev)	F: Flange Mtg.	(Viewed from Shaft End)	05: Two Pressure Two Flow Control Type by System Pressure	B: 2.5 - 7 C: 2.5 - 16 H: 2.5 - 21	B: 2.5 - 7 C: 2.5 - 16 H: 2.5 - 21	None: Axial Port S: Side Port	K: Keyed Shaft	32
A37 (36.9 cm ³ /rev)								L: Foot Mtg.
A56 (56.2 cm ³ /rev)								32

Consult Yuken when detailed material such as dimensions figures is required.

Series Variable Displacement Piston Pumps, Two-Pressure Two-Flow Control Type By Solenoid Valve

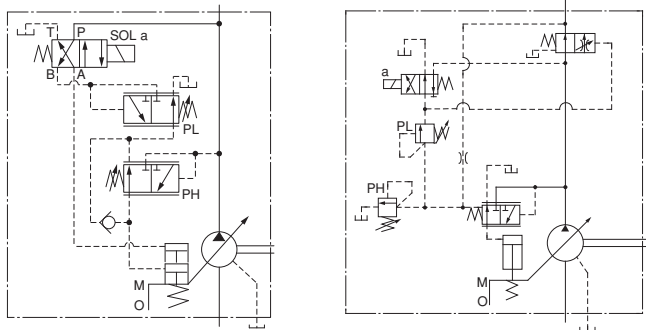
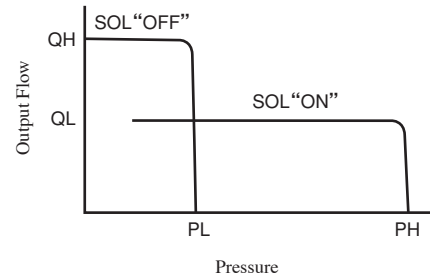
Graphic Symbols

A16/A22/A37/A56
A70/A90/A145
Performance Characteristics

Specifications

Model Numbers	Geometric Displacement cm ³ /rev	Delivery Volume Adj. Range cm ³ /rev		Operating Pressure MPa		Shaft Speed Range r/min	
		Large Displacement (QH)	Small Displacement (QL)	Rated	Intermittent	Max.	Min.
A16- *R-06- * *-S-K- *-33	15.8	2.6 - 15.8	2.6 - 11.1	16	21	1800	600
A22- *R-06- * *-S-K- *-33	22.2	3.7 - 22.2	3.7 - 15.5	16	16		
A37- *R-06- * *-S-K- *-33	36.9	4.1 - 36.9	4.1 - 20.1	16	21		
A56- *R-06- * *-S-K- *-33	56.2	3.4 - 56.2	3.4 - 25.1	16	21		
A70- *R06S *-70	70.0	36 - 70.0	3 - 70.0	25	25		
A90- *R06S *-70	91.0	56 - 91.0	3 - 70.0	25	25		
A145- *R06S *-60	145	83 - 145	3 - 145	25	25		

Model Number Designation

A16	-F	-R	-06	-B	C	-S	-K	A200	-33
Series Number	Mounting	Direction of Rotation	Control Type	Pres. Adj. Range for High Pressure MPa	Pres. Adj. Range for Low Pressure MPa	Port Position	Shaft Extension	Coil Type of Solenoid Valve	Design Number
A16 (15.8 cm ³ /rev)	F: Flange Mtg. L: Foot Mtg.	(Viewed from Shaft End) R: Clockwise (Normal)	06: Two-Pressure Two-Flow Control Type by Solenoid Valve	B: 2.5 - 7 C: 2.5 - 16 H: 2.5 - 21	B: 2.5 - 7 C: 2.5 - 16 H: 2.5 - 21	S: Side Port	K: Keyed Shaft	AC A100, A120 A200, A240 DC D12, D24 D48 R(AC→DC Rectified) R100, R200	33
A22 (22.2 cm ³ /rev)									33
A37 (36.9 cm ³ /rev)									33
A56 (56.2 cm ³ /rev)									33

A70	-F	R	06	S	A200	-70
Series Number	Mounting	Direction of Rotation	Control Type	Port Position	Coil Type of Solenoid Valve	Design Number
A70 (70.0 cm ³ /rev)	F: Flange Mtg. L: Foot Mtg.	(Viewed from Shaft End) R: Clockwise (Normal)	06: Two-Pressure Two-Flow Control Type by Solenoid Valve	S: Side Port	AC A100, A120 A200, A240 DC D12, D24 D48 R(AC→DC Rectified) R100, R200	70
A90 (91.0 cm ³ /rev)						70
A145 (145 cm ³ /rev)						60

Consult Yuken when detailed material such as dimensions figures is required.

Series Variable Displacement Piston Pumps, Pilot Pressure Control Type Pressure Compensator

Graphic Symbol

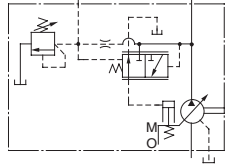

■ Performance Characteristics

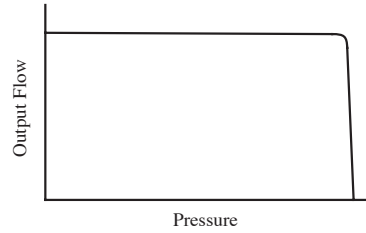

■ Specifications

Model Numbers	Geometric Displacement cm ³ /rev	Minimum Adj. Flow cm ³ /rev	Operating Pressure MPa		Minimum Adj. Pres. MPa	Shaft Speed Range r/min		Approx. Mass kg	
			Rated ^{*2}	Intermittent ^{*1}		Max.	Min.	Flange Mtg.	Foot Mtg.
A10-FR07-13	10.0	2	16	21	2.0	1800	600	9.5	—
A16- [*] R-07- [*] -K-32	15.8	4	16	21	1.2	1800	600	21	23.2
A22- [*] R-07- [*] -K-32	22.2	6	16	16	1.2	1800	600	21	23.2
A37- [*] R-07- [*] -K-32	36.9	10	16	21	1.2	1800	600	29	33.3
A56- [*] R-07- [*] -K-32	56.2	12	16	21	1.2	1800	600	36	40.3
A70- [*] R07S-70	70.0	36	25	25	2	1800	600	60.3	72.3
A90- [*] R07S-70	91.0	56	25	25	2	1800	600	77.5	98
A145- [*] R07S-60	145	83	25	25	2	1800	600	94	119

- ★1. Whenever setting pressure, make sure the full cut-off pressure never exceeds the maximum intermittent pressure.
- ★2. When operating the pump exceeding the rated pressure, operating conditions are restricted.
Refer to page A-28 for details.

■ Model Number Designation

A16	-F	-R	-07	-S	-K	-32
Series Number	Mounting	Direction of Rotation	Control Type	Port Position	Shaft Extension	Design Number
A16 (15.8 cm ³ /rev)	F: Flange Mtg. L: Foot Mtg.	(Viewed from Shaft End) R: Clockwise ^{*1} (Normal)	07: Pilot Pressure Control Type Pressure Compensator	None: Axial Port S: Side Port	K: Keyed Shaft	32
A22 (22.2 cm ³ /rev)						32
A37 (36.9 cm ³ /rev)						32
A56 (56.2 cm ³ /rev)						32

A70	-F	R	07	S	-70
Series Number	Mounting	Direction of Rotation	Control Type	Port Position	Design Number
A10 (10.0 cm ³ /rev)	F: Flange Mtg. ^{*2}	(Viewed from Shaft End) R: Clockwise ^{*1} (Normal)	07: Pilot Pressure Control Type Pressure Compensator	—	13
A70 (70.0 cm ³ /rev)	F: Flange Mtg.			S: Side Port	70
A90 (91.0 cm ³ /rev)	L: Foot Mtg.			70	
A145 (145 cm ³ /rev)	L: Foot Mtg.			60	

- ★1. Available to supply pump with anti-clockwise rotation. Consult Yuken for details.
- ★2. When A10 pump is used as the foot Mtg., order the Mtg. bracket kit shown below separately.
Refer to page A-17 for dimensions of the Mtg. bracket.

Mtg. Bracket Kit Numbers	Approx. Mass kg
LP-1A-10	2.2

Note: The mounting bracket kit consists of a mounting bracket, 2 hex. bolts and 2 plain washers.

Performance Characteristics

For performance characteristics, refer to models of pressure compensator type on page A-31 to A-34, A-36 to A-38 and A-40.

Pipe Flange Kit

For pipe flange, refer to form of pressure compensator type on page A-29.

Flange Mtg. : A10-FR07

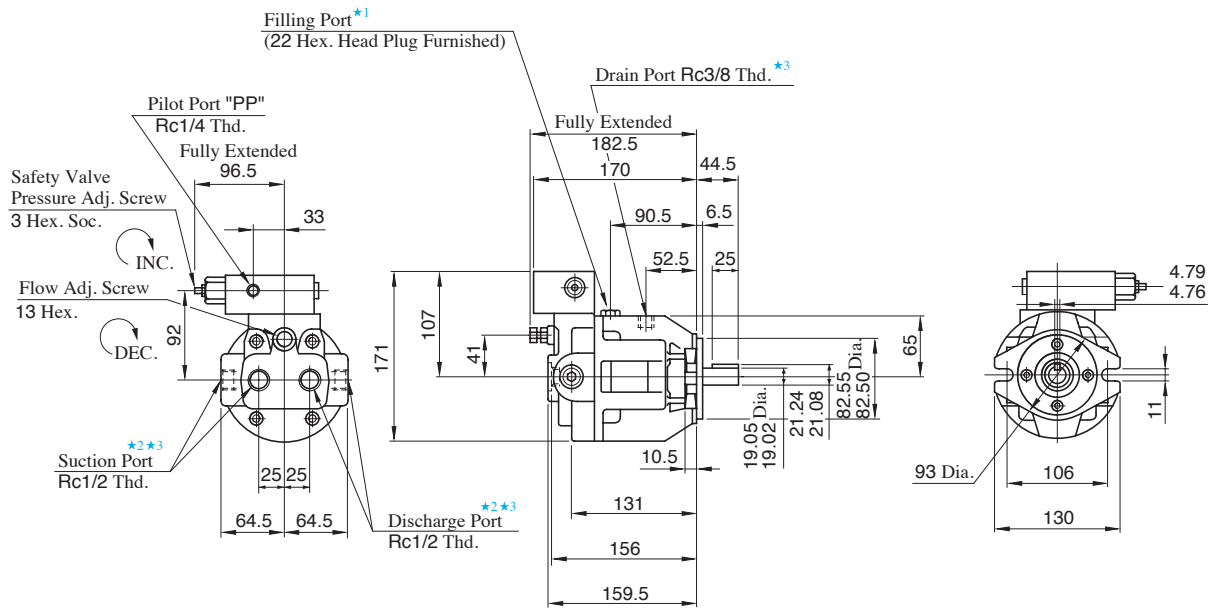

- ★1. Install the pump so that the "Filling Port" is at the top.
- ★2. Use either port of two suction and discharge ports at your option. Keep the remaining ports plugged.
- ★3. As the tightening torques of suction, discharge and drain port fittings, conform to the below.

Model Numbers	Tightening Torque Nm	
	Suction Port & Discharge Port	Drain Port
A10-FR07-12	65 - 75	40 - 50

Axial Port Type

**Flange Mtg. : A16-F-R-07-K
A22-F-R-07-K**

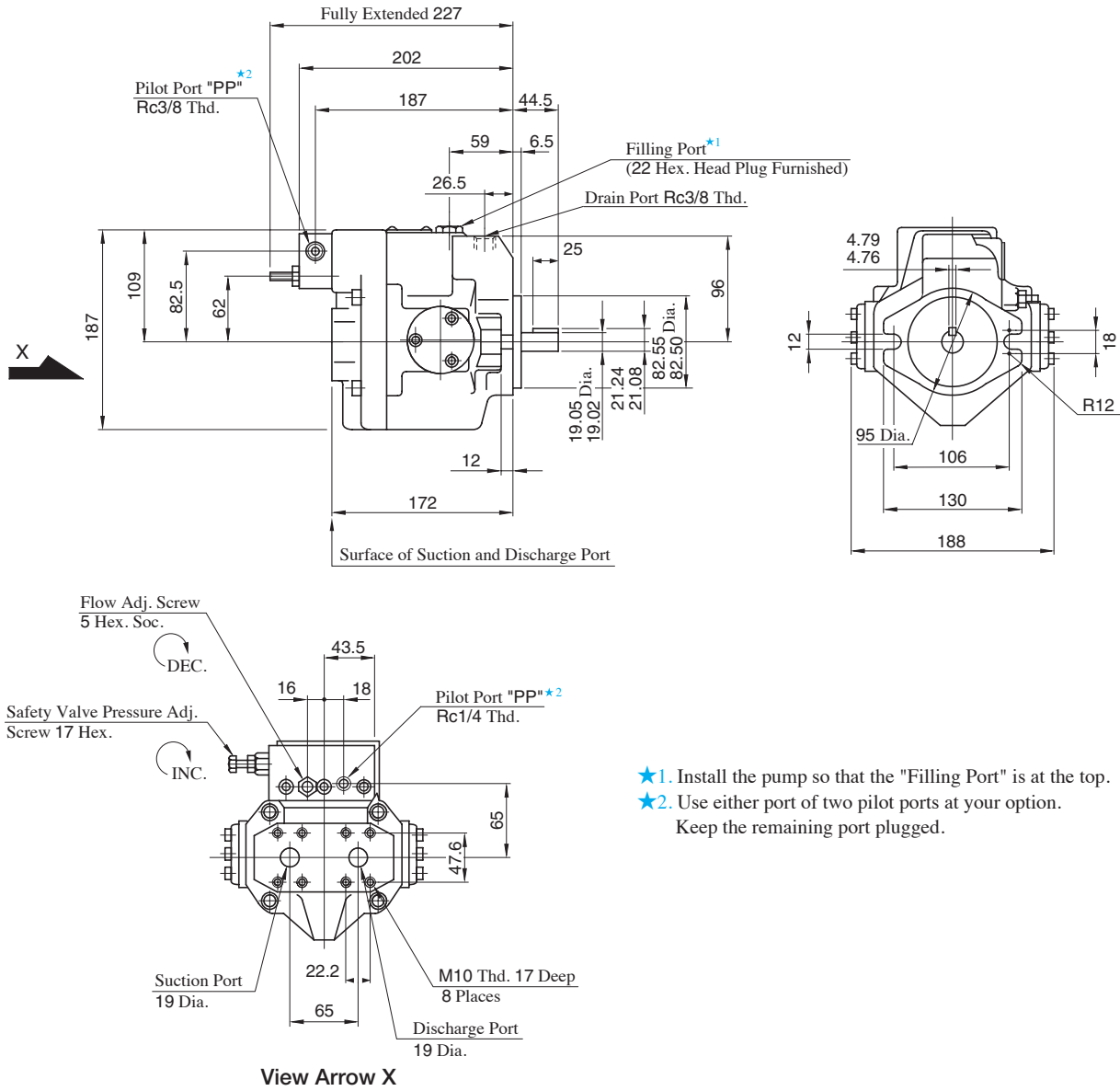

- ★1. Install the pump so that the "Filling Port" is at the top.
- ★2. Use either port of two pilot ports at your option. Keep the remaining port plugged.

● **Axial Port Type**

Port mounting dimensions are the same as those of pressure compensator model. Refer to page A-42 for port mounting dimensions.

● **Foot Mounting Type**

Mounting bracket is common to that of pressure compensator model. Refer to page A-42 for the dimensions of mounting bracket.

Side Port Type

Flange Mtg. : A37-F-R-07-S-K

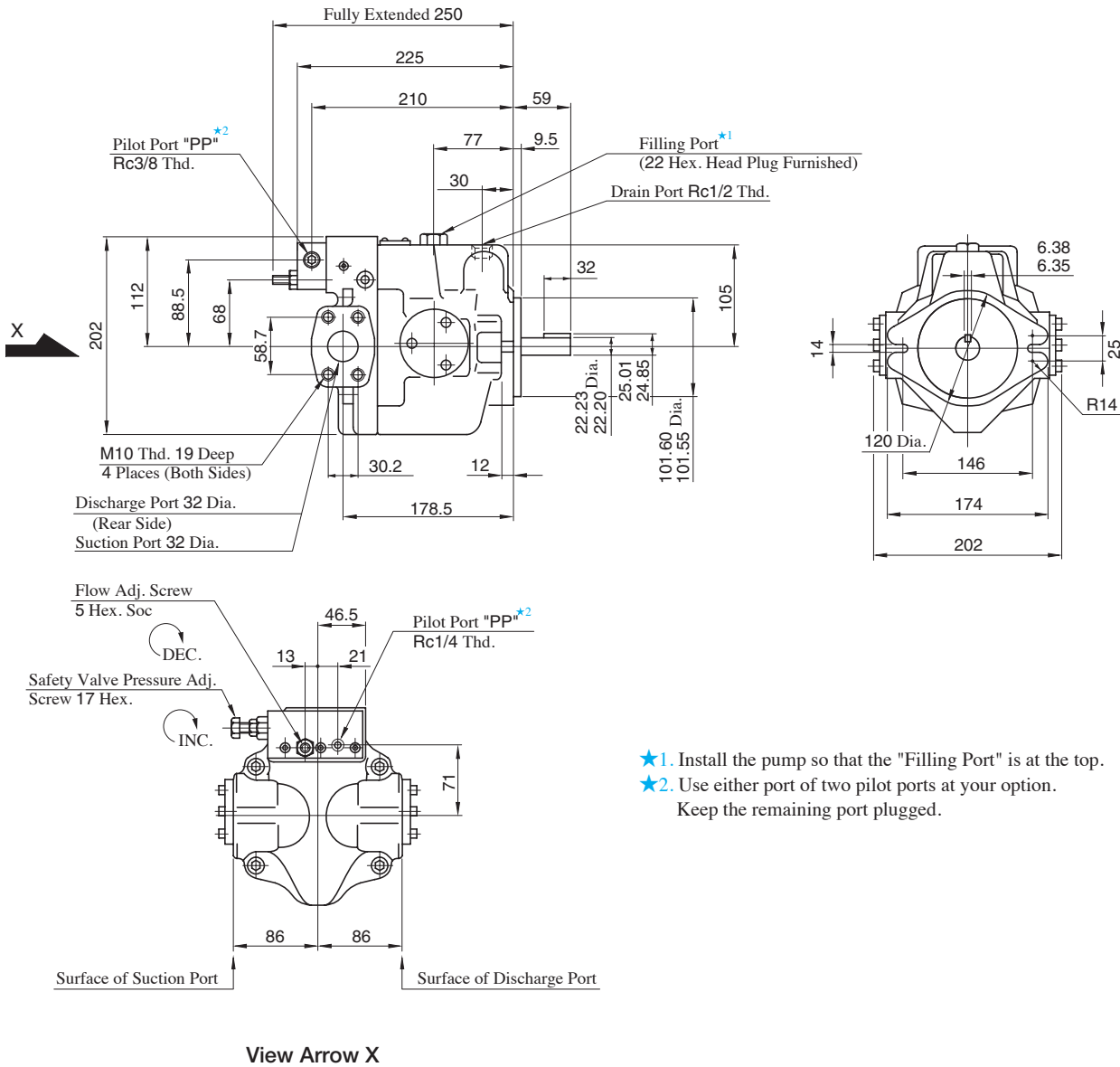

- ★1. Install the pump so that the "Filling Port" is at the top.
- ★2. Use either port of two pilot ports at your option. Keep the remaining port plugged.

● Axial Port Type

Port mounting dimensions are the same as those of pressure compensator model. Refer to page A-43 for port mounting dimensions.

● Foot Mounting Type

Mounting bracket is common to that of pressure compensator model. Refer to page A-43 for the dimensions of mounting bracket.

Side Port Type

Flange Mtg. : A56-F-R-07-S-K

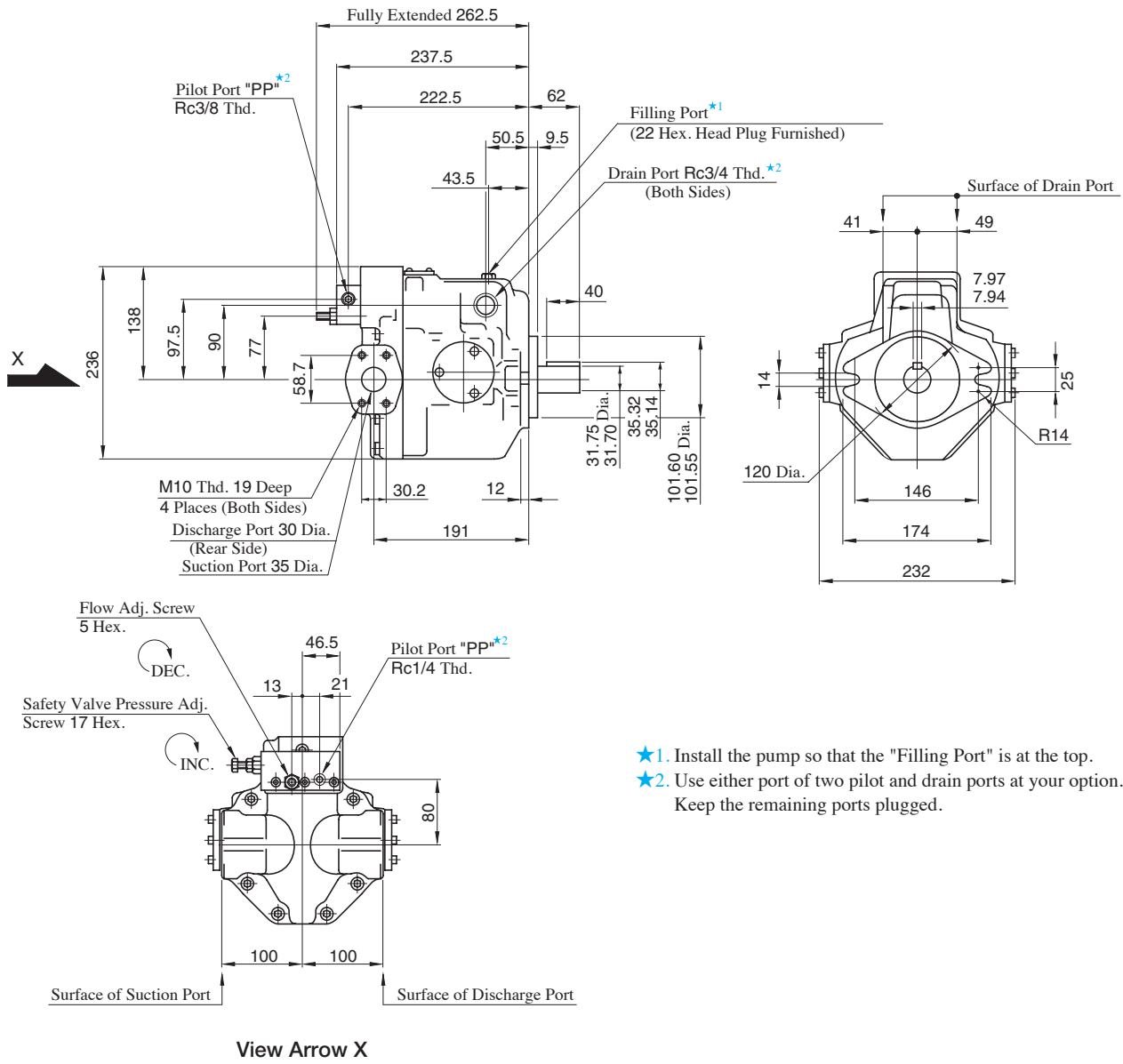

- ★1. Install the pump so that the "Filling Port" is at the top.
- ★2. Use either port of two pilot and drain ports at your option. Keep the remaining ports plugged.

● **Axial Port Type**

Port mounting dimensions are the same as those of pressure compensator model. Refer to page A-44 for port mounting dimensions.

● **Foot Mounting Type**

Mounting bracket is common to that of pressure compensator model. Refer to page A-44 for the dimensions of mounting bracket.

Flange Mtg. : A70-FR07S

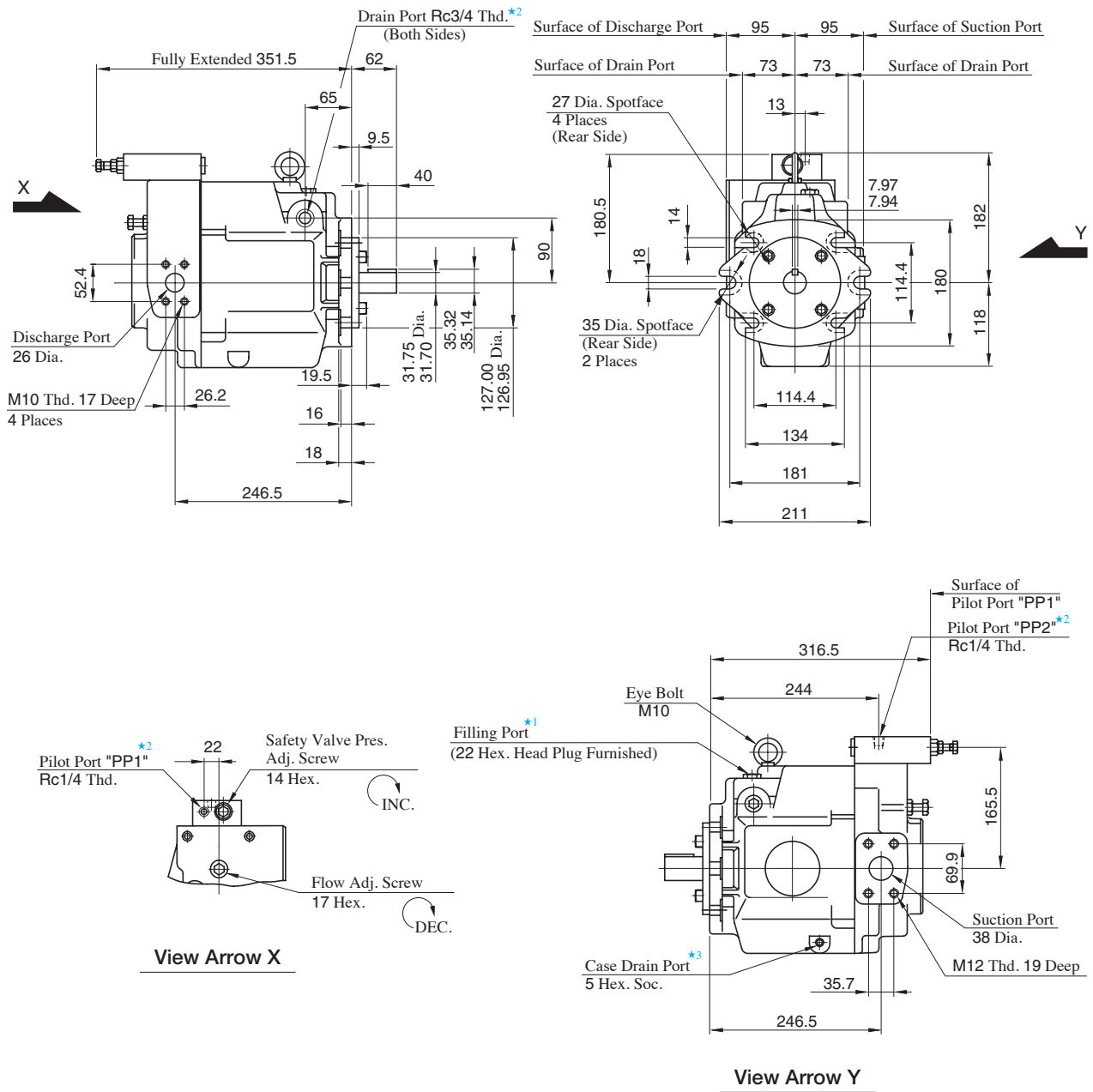

- ★1. Install the pump so that the "Filling Port" is at the top.
- ★2. Use either port of two pilot and drain ports at your option. Keep the remaining ports plugged.
- ★3. Case drain port is available for use when draining hydraulic fluid from pump casing.

● Foot Mounting Type

Mounting bracket is common to that of pressure compensator model.
Refer to page A-45 for the dimensions of mounting bracket.

Flange Mtg. : A90-FR07S

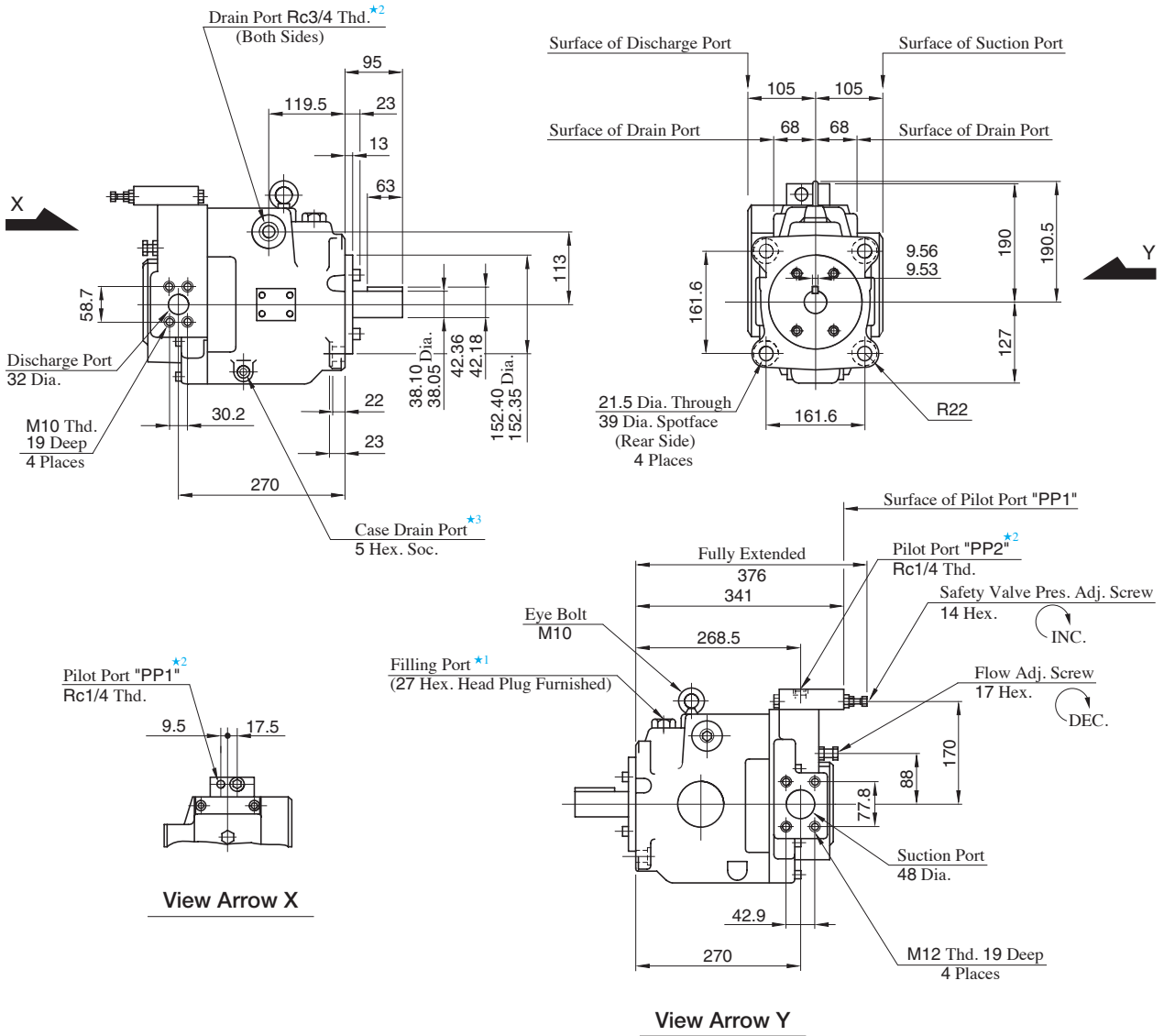

- ★1. Install the pump so that the "Filling Port" is at the top.
- ★2. Use either port of two pilot and drain ports at your option. Keep the remaining ports plugged.
- ★3. Case drain port is available for use when draining hydraulic fluid from pump casing.

● **Foot Mounting Type**

Mounting bracket is common to that of pressure compensator model.
Refer to page A-46 for the dimensions of mounting bracket.

Flange Mtg. : A145-FR07S

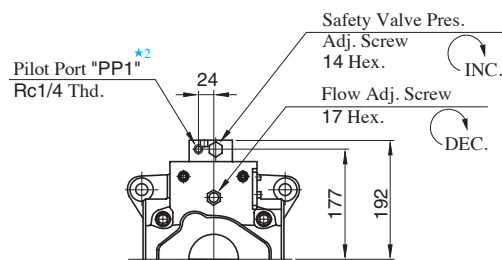
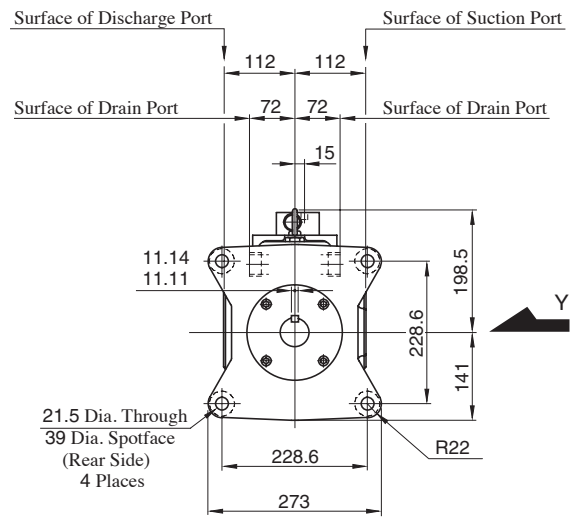
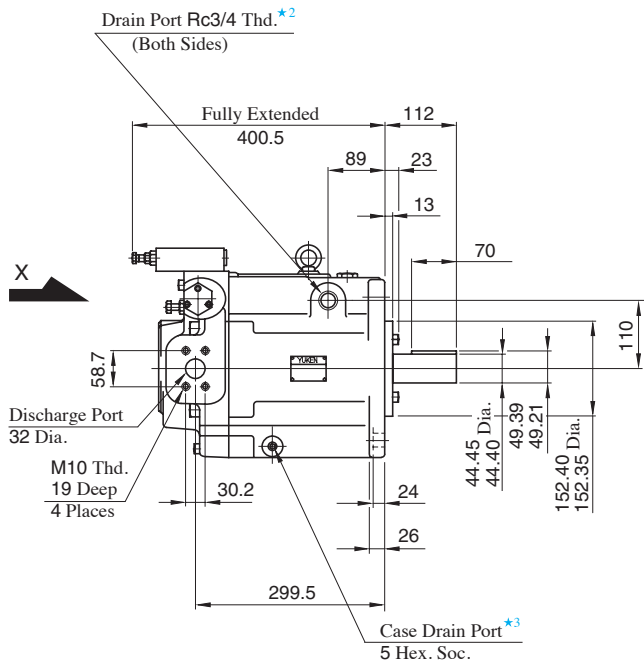

View Arrow X

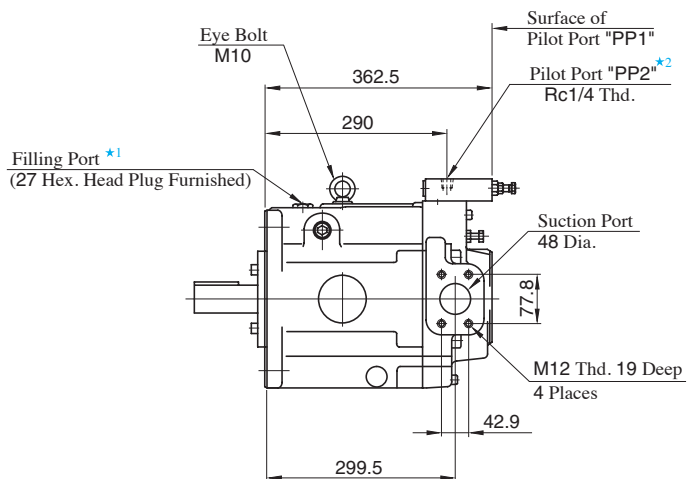

View Arrow Y

- ★1. Install the pump so that the "Filling Port" is at the top.
- ★2. Use either port of two pilot and drain ports at your option. Keep the remaining ports plugged.
- ★3. Case drain port is available for use when draining hydraulic fluid from pump casing.

● Foot Mounting Type

Mounting bracket is common to that of pressure compensator model.
Refer to page A-47 for the dimensions of mounting bracket.

A Series Variable Displacement Piston Pumps, Constant Power Control Type

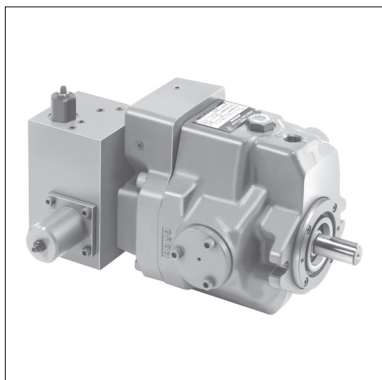

Performance Characteristics

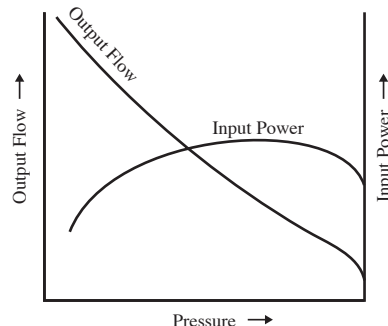

Graphic Symbols

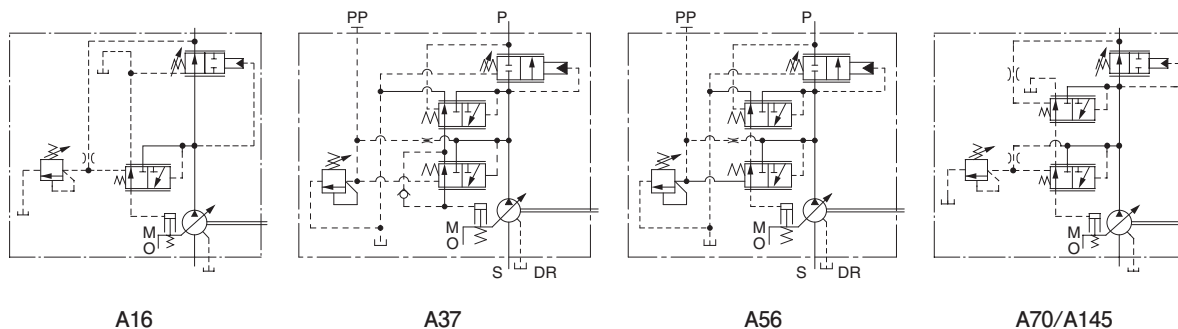

Specifications

Model Numbers	Geometric Displacement cm ³ /rev	Minimum Adj. Flow cm ³ /rev	Operating Pres. MPa	Shaft Speed Range r/min		Approx. Mass kg	
			Max.	Max.	Min.	Flange Mtg.	Foot Mtg.
A16- * -R-09- * - * -K-32	15.8	—	21 ^{★1}	1800	600	29.0	31.2
A37- * -R-09- * - * -K-32	36.9	—	21 ^{★1}	1800	600	37.0	41.3
A56- * -R-09- * - * -K-32	56.2	—	21 ^{★1}	1800	44.0	44.0	48.3
A70- *R09* S-70	70.0	36	25	1800	600	72.8	84.8
A145- *R09* S-60	145	83	25	1800	600	110	135

★1. Maximum operating pressure of A16/A37/A56 varies according to input power setting. See “Model Number Designation” for details.

★2. Minimum adjustment flow of A70/A145 is absolutely minimum flow that can be adjusted with flow adjustment screw.

Model Number Designation

● A16/A37/A56

A16	-F	-R	-09	-A		-16M	-K	-32		
Series Number	Mounting	Direction of Rotation	Control Type	Input Power Setting		Specify Control Pres.	Shaft Extension	Design Number		
A16 (15.8 cm ³ /rev)	F: Flange Mtg.	(Viewed from Shaft End)	09: Constant Power Control Type	A : 3.7 kW	E : 2.2 kW	7M : 7 Pa 10.5M : 10.5 Pa 14M : 14 Pa 16M : 16 Pa 17.5M : 17.5 Pa 21M : 21 Pa	K: Keyed Shaft	32		
A37 (36.9 cm ³ /rev)				B : 5.5 kW	F : 1.5 kW			A : 3.7 kW	C : 7.5 kW	32
A56 (56.2 cm ³ /rev)	L: Foot Mtg.	R: Clockwise* ¹ (Normal)		A : 3.7 kW	E : 15 kW			B : 5.5 kW	F : 18.5 kW	C : 7.5 kW

● A70/A145

A70	-F	R	09	-A		S	-70			
Series Number	Mounting	Direction of Rotation	Control Type	Input Power Setting		Direction of Port	Design Number			
A70 (70 cm ³ /rev)	F: Flange Mtg.	(Viewed from Shaft End)	09: Constant Power Control Type	A : 15 kW	C : 22 kW	S: Side Port	70			
A145 (145 cm ³ /rev)	L: Foot Mtg.	R: Clockwise* ¹ (Normal)		B : 18.5 kW	D : 30 kW		A : 15 kW	E : 37 kW	60	
				B : 18.5 kW	F : 45 kW		C : 22 kW	G : 55 kW		D : 30 kW

★1. Available to supply pump with anti-clockwise rotation. Consult Yuken for details.

★2. Specify control pressure of A16/A37/A56 with lower than maximum operating pressure depending on input power setting.

Model	Maximum Operating Pressure MPa								
	1.5 kW	2.2 kW	3.7 kW	5.5 kW	7.5 kW	11 kW	15 kW	18.5 kW	22 kW
A16	10.5	16	21	21	—	—	—	—	—
A37	—	—	16	21	21	21	—	—	—
A56	—	—	10.5	14	17.5	21	21	21	21

Pipe Flange Kits

Pipe flange kits are available. When ordering, specify the kit number from the table below.

Pump Model Numbers	Name of Port	Pipe Flange Kit Numbers		
		Threaded Connection	Socket Welding* ¹	Butt Welding
A16- *-R-09	Suction	F5-06-A-10	F5-06-B-10	F5-06-C-10
	Discharge	—* ²	—* ²	—* ²
A37- *-R-09	Suction	F5-10-A-10	F5-10-B-10	F5-10-C-10
A56- *-R-09	Discharge	F5-06-A-10	F5-06-B-10	F5-06-C-10
A70- *-R-09	Suction	F5-12-A-10	F5-12-B-10	F5-12-C-10
	Discharge	F5-08-A-10	F5-08-B-10	F5-08-C-10
A145- *-R-09	Suction	F5-16-A-10	F5-16-B-10	F5-16-C-10
	Discharge	F5-10-A-10	F5-10-B-10	F5-10-C-10

★1. In case of using socket welding flanges, there is a case where the operating pressure should be set lower than the normal because of strength of flanges. Therefore, please pay cautious attention to the operating pressure when the socket welding flanges are used.

★2. Discharge port for pump model "A16" is available only the threaded connections.

● Detail of the pipe flange kits are shown on pages A-258 and A-259.

Typical Performance Characteristics at 1500 r/min

● A16

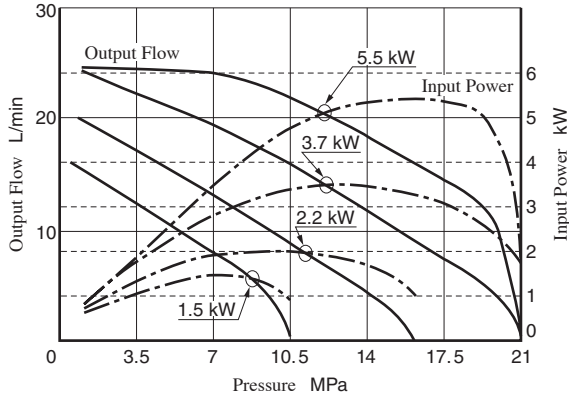

● A70

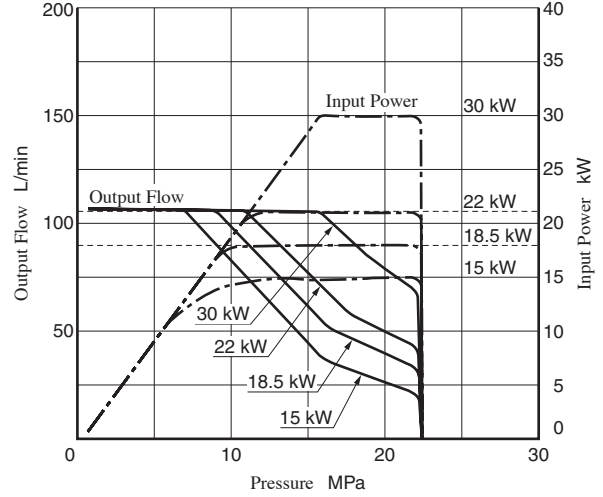

● A37

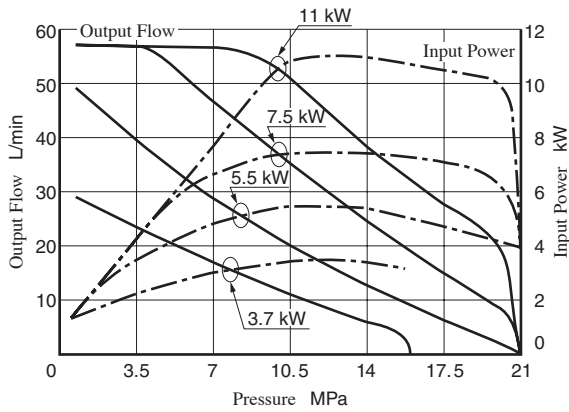

● A145

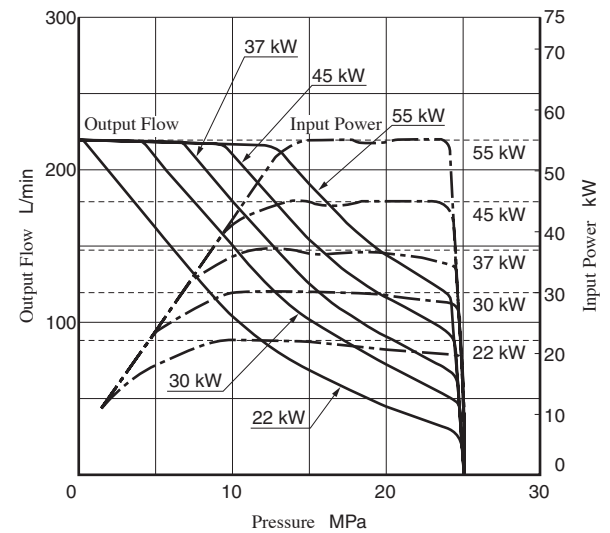

● A56

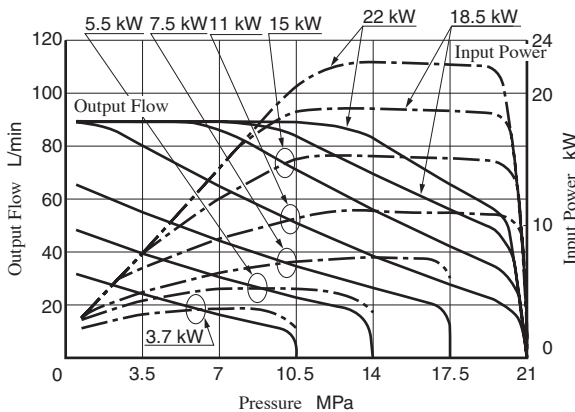

Flange Mtg. : A16-F-R-09- *-K

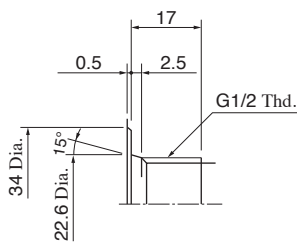
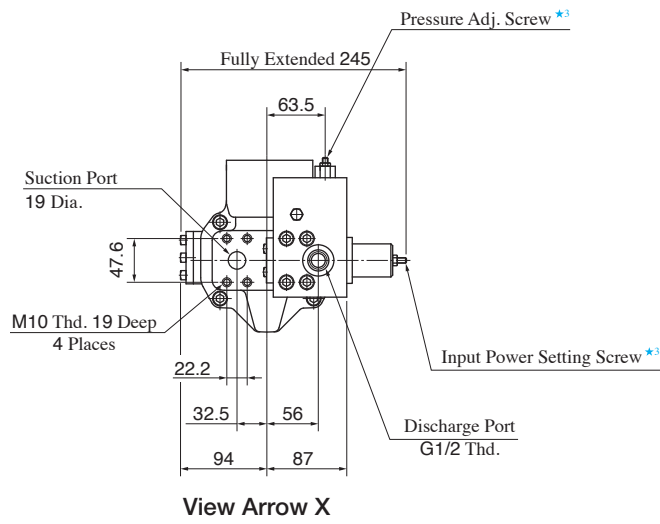
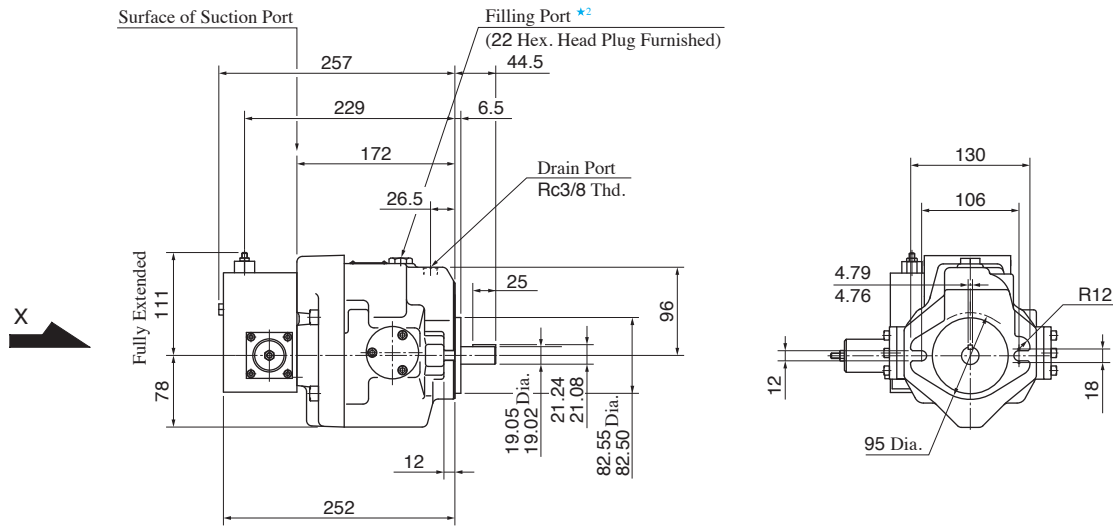

- ★1. Detail of Discharge Port
- ★2. Install the pump so that the "Filling Port" is at the top.
- ★3. Do not touch the screw because it is adjusted at the time of shipment.

● Foot Mounting Type

Mounting bracket is common to that of pressure compensator model.
Refer to page A-42 for the dimensions of mounting bracket.

Flange Mtg. : A37-F-R-09- * -K

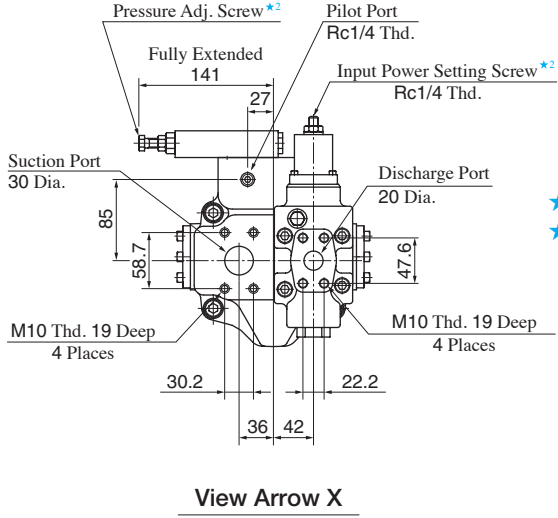
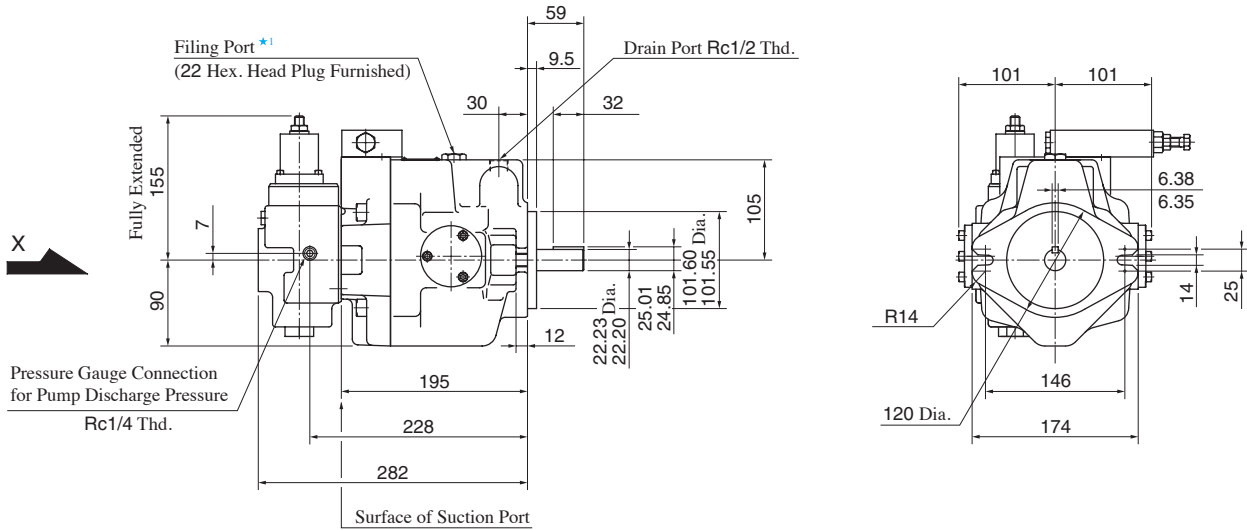

- ★1. Install the pump so that the "Filling Port" is at the top.
- ★2. Do not touch the screw because it is adjusted at the time of shipment.

Foot Mtg. : A37-L-R-09- * -K

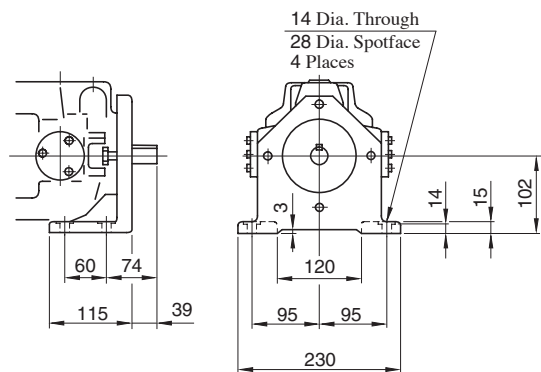

● For other dimensions, refer to "Flange Mtg.".

Flange Mtg. : A56-F-R-09- * -K

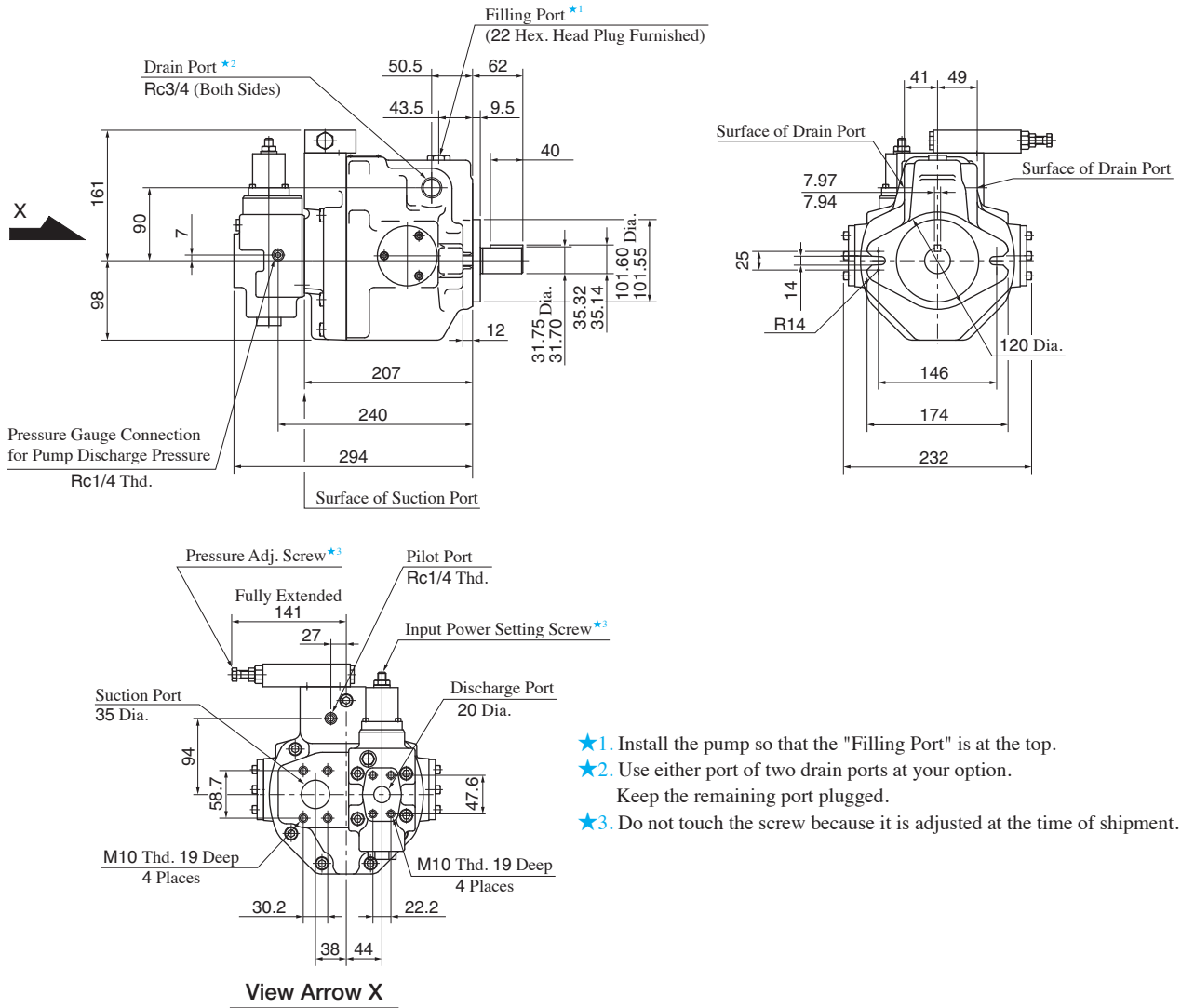

Foot Mtg. : A56-L-R-09- * -K-32

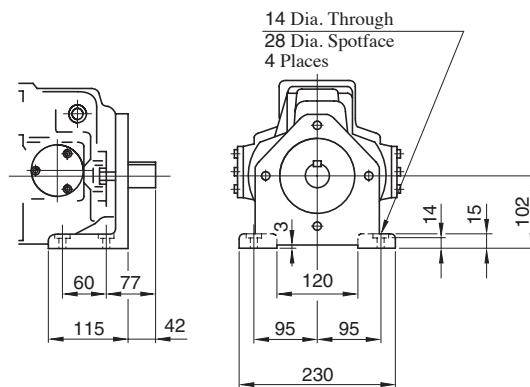

● For other dimensions, refer to "Flange Mtg.".

Flange Mtg. : A70-FR09 * S

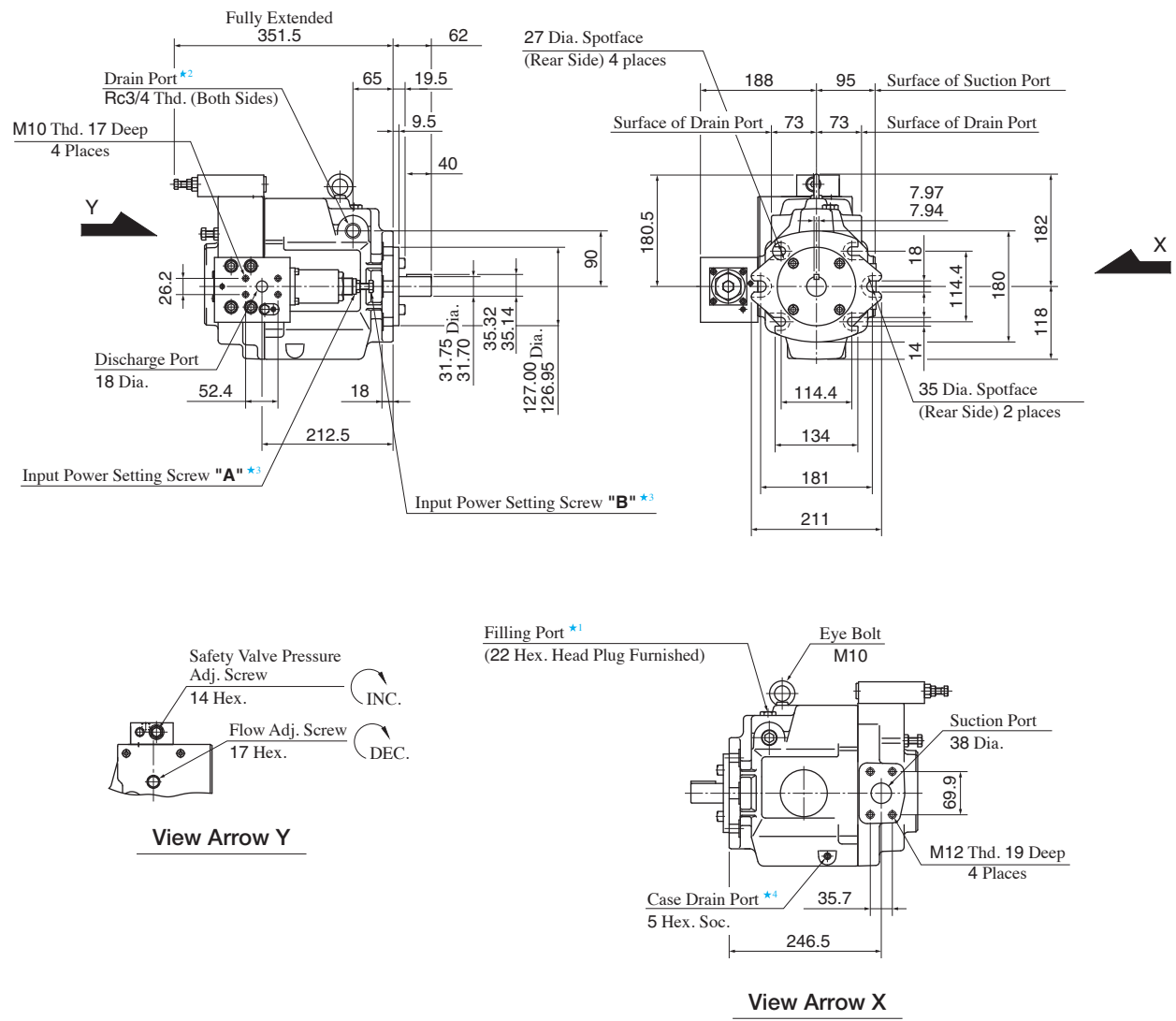

- ★1. Install the pump so that the "Filling Port" is at the top.
- ★2. Use either port of two drain ports at your option. Keep the remaining port plugged.
- ★3. Do not touch the screw because it is adjusted at the time of shipment.
- ★4. Case drain port is available for use when draining hydraulic fluid from pump casing.

● **Foot Mounting Type**

Mounting bracket is common to that of pressure compensator model.
Refer to page A-45 for the dimensions of mounting bracket.

Flange Mtg. : A145-FR09 * S

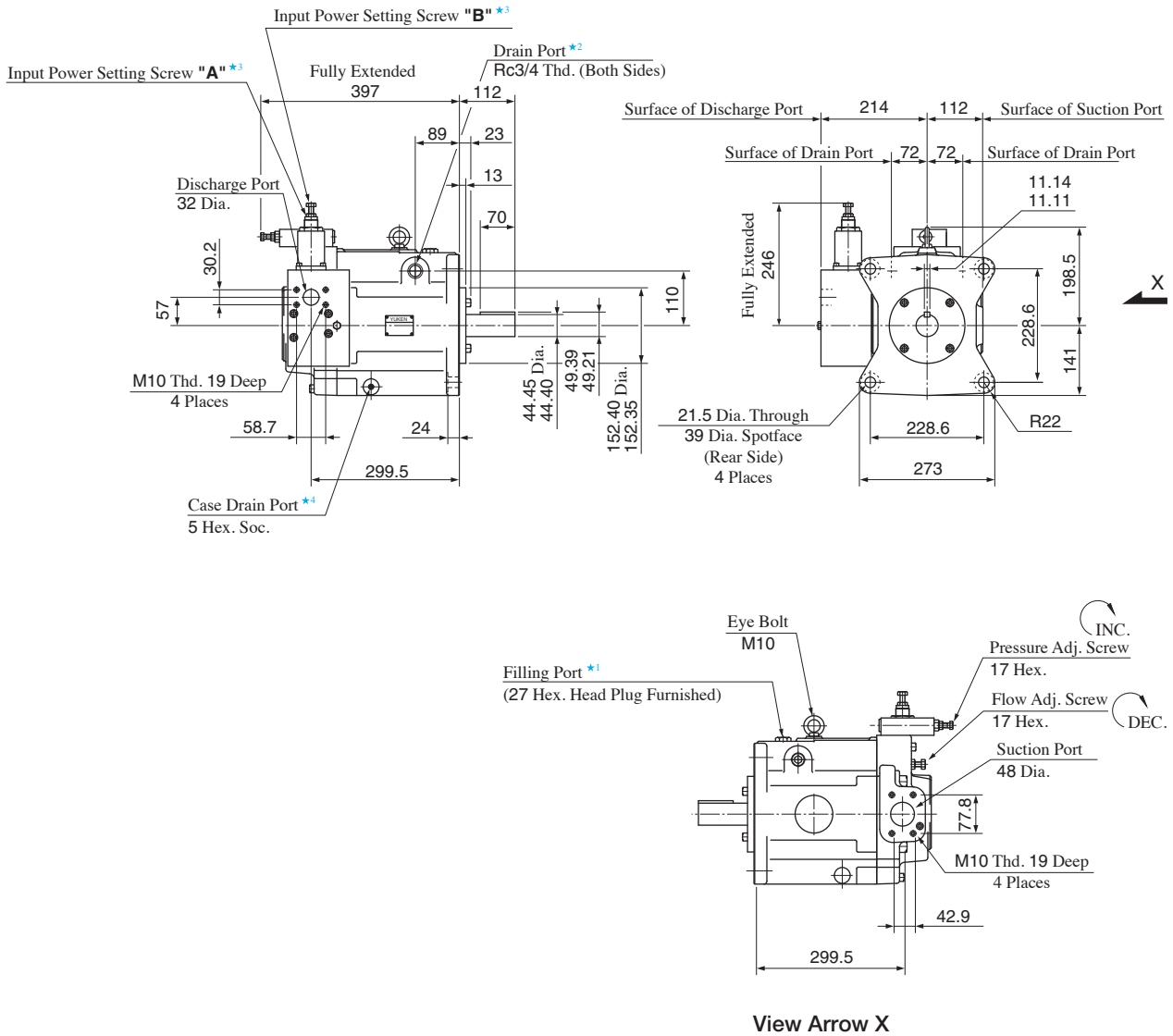

- ★1. Install the pump so that the "Filling Port" is at the top.
- ★2. Use either port of two drain ports at your option. Keep the remaining port plugged.
- ★3. Do not touch the screw because it is adjusted at the time of shipment.
- ★4. Case drain port is available for use when draining hydraulic fluid from pump casing.

● Foot Mounting Type

Mounting bracket is common to that of pressure compensator model.
Refer to page A-47 for the dimensions of mounting bracket.

Series Variable Displacement Piston Pumps - Single Pump, Simple Two-Pressure Two-Flow Control Type

Specifications

Model Numbers	Geometric Displacement cm ³ /rev	Output Flow Adj. Range cm ³ /rev		Operating Pressure MPa		Shaft Speed Range r/min
		Large Displacement (QH)	Small Displacement (QL)	Rated	Intermittent	
A16- *-R-00-H-K-32500	15.8	4-15.8	3-10	16	21	600-1800
A37- *-R-00-H-K-32500	36.9	7-36.9	3-18	16	21	
A56- *-R-00-H-K-32500	56.2	9-56.2	3-27.7	16	21	
A70- *R00HS-70500	70.0	36-70.0	★-24	21	21	
A90- *R00HS-70500	91	56-91.0	★-45	21	21	
A145- *R00HS-60500	145	83-145	★-70	21	21	

Note) ★: Minimum adjustment flow of relief valve, which is for setting with PH pressure. (Relief valve is external set.)

Performance Characteristics

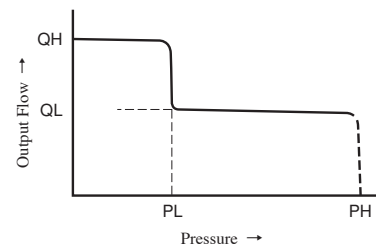

Graphic Symbol

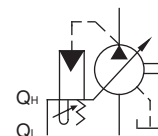

Instruction

As the pump does not have full cut-off function, setting relief valve of PH pressure (maximum pressure on circuit) for pump discharge line is absolutely required.

Model Number Designation

● A16-A56

A16	-F	-R	-00	-H	-K	-32500
Series Number	Mounting	Direction of Rotation	Control Type	Pres. Adj. Range MPa	Shaft Extension	Design Number
A16 (15.8 cm ³ /rev)	F : Flange Mtg. L : Foot Mtg.	(Viewed from Shaft End) R : Clockwise★ (Normal)	00 : Special Control Type	H : 1.2-21	K : Keyed Shaft	32500
A37 (36.9 cm ³ /rev)						32500
A56 (56.2 cm ³ /rev)						32500

● A70-A145

A70	-F	R	00	H	S	-70500
Series Number	Mounting	Direction of Rotation	Control Type	Pres. Adj. Range MPa	Port Position	Design Number
A70 (70.0 cm ³ /rev)	F : Flange Mtg. L : Foot Mtg.	(Viewed from Shaft End) R : Clockwise★ (Normal)	00 : Special Control Type	H : 2-21	S : Side Port	70500
A90 (91.0 cm ³ /rev)						70500
A145 (145 cm ³ /rev)						60500

★ Available to supply pump with anti-clockwise rotation. Consult Yuken for details.

Consult Yuken when detailed material such as dimensions figures is required.

Series Variable Displacement Piston Pumps – Double Pumps, Pressure Compensator Type

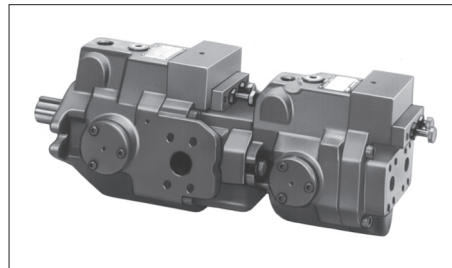

Graphic Symbol

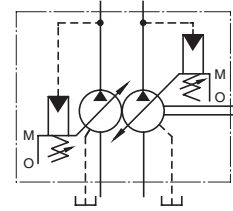

Specifications

Model Numbers		Geometric Displacement cm ³ /rev	Min. Adj. Flow cm ³ /rev	Operating Pressure MPa		Shaft Speed Range r/min		Approx. Mass kg	
				Rated	Intermittent	Max.	Min.	Flange Mtg.	Foot Mtg.
A1616- *R01 *01 * * K-32	Outboard Pump	15.8	4	16	21	1800	600	35.5	37.7
	Inboard Pump	15.8	4	16	21				
A1622- *R01 *01 * * K-32	Outboard Pump	15.8	4	16	21	1800	600	35.5	37.7
	Inboard Pump	22.2	6	16	16				
A2222- *R01 *01 * * K-32	Outboard Pump	22.2	6	16	16	1800	600	35.5	37.7
	Inboard Pump	22.2	6	16	16				
A1637- *R01 *01 * * K-32	Outboard Pump	15.8	4	16	21	1800	600	50	54.3
	Inboard Pump	36.9	10	16	21				
A2237- *R01 *01 * * K-32	Outboard Pump	22.2	6	16	16	1800	600	50	54.3
	Inboard Pump	36.9	10	16	21				
A1656- *R01 *01 * * K-32	Outboard Pump	15.8	4	16	21	1800	600	54.5	58.8
	Inboard Pump	56.2	12	16	21				
A2256- *R01 *01 * * K-32	Outboard Pump	22.2	6	16	16	1800	600	54.5	58.8
	Inboard Pump	56.2	12	16	21				
A1670- *R01 *01 * * -70	Outboard Pump	15.8	4	16	21	1800	600	77.5	89.5
	Inboard Pump	70.0	36	25	28				
A2270- *R01 *01 * * -70	Outboard Pump	22.2	6	16	16	1800	600	77.5	89.5
	Inboard Pump	70.0	36	25	28				
A3770- *R01 *01 * * -70	Outboard Pump	36.9	10	16	21	1800	600	86.5	98.5
	Inboard Pump	70.0	36	25	28				
A1690- *R01 *01 * * -70	Outboard Pump	15.8	4	16	21	1800	600	88	108.5
	Inboard Pump	91.0	56	25	28				
A2290- *R01 *01 * * -70	Outboard Pump	22.2	6	16	16	1800	600	88	108.5
	Inboard Pump	91.0	56	25	28				
A3790- *R01 *01 * * -70	Outboard Pump	36.9	10	16	21	1800	600	100.5	121
	Inboard Pump	91.0	56	25	28				
A5690- *R01 *01 * * -70	Outboard Pump	56.2	12	16	21	1800	600	107.5	128
	Inboard Pump	91.0	56	25	28				
A16145- *R01 *01 * * -60	Outboard Pump	15.8	4	16	21	1800	600	109	134
	Inboard Pump	145	83	25	28				
A22145- *R01 *01 * * -60	Outboard Pump	22.2	6	16	16	1800	600	109	134
	Inboard Pump	145	83	25	28				
A37145- *R01 *01 * * -60	Outboard Pump	36.9	10	16	21	1800	600	121.5	146.5
	Inboard Pump	145	83	25	28				
A56145- *R01 *01 * * -60	Outboard Pump	56.2	12	16	21	1800	600	128.5	153.5
	Inboard Pump	145	83	25	28				

Consult Yuken when detailed material such as dimensions figures is required.

Model Number Designation

A1637	-F	-R	Outboard Pump		Inboard Pump (Driven End)		S	K	-32			
			01	C	01	C						
Series Number	Mounting	Direction of Rotation	Control Type	Pres. Adj. Range MPa	Control Type	Pres. Adj. Range MPa	Port Position of Outboard Pump	Shaft Extension	Design Number			
A1616 (15.8/15.8 cm ³ /rev)	F: Flange Mtg.	(Viewed from Shaft End)	01: Pressure Compensator Type	B : 1.2- 7 C : 1.2-16 D : 1.2-21	01: Pressure Compensator Type	B : 1.2- 7 C : 1.2-16 D : 1.2-21	S: Side Port	K: Keyed Shaft	32			
A1622 (15.8/22.2 cm ³ /rev)				B : 1.2- 7 C : 1.2-16		32						
A2222 (22.2/22.2 cm ³ /rev)				B : 1.2- 7 C : 1.2-16		32						
A1637 (15.8/36.9 cm ³ /rev)				B : 1.2- 7 C : 1.2-16 H : 1.2-21		None: Axial Port			None: Keyed Shaft	32		
A2237 (22.2/36.9 cm ³ /rev)				B : 1.2- 7 C : 1.2-16						32		
A1656 (15.8/56.2 cm ³ /rev)				B : 1.2- 7 C : 1.2-16 H : 1.2-21						32		
A2256 (22.2/56.2 cm ³ /rev)				B : 1.2- 7 C : 1.2-16						32		
A1670 (15.8/70.0 cm ³ /rev)				B : 1.2- 7 C : 1.2-16 H : 1.2-21						70		
A2270 (22.2/70.0 cm ³ /rev)				B : 1.2- 7 C : 1.2-16						70		
A3770 (36.2/70.0 cm ³ /rev)				B : 1.2- 7 C : 1.2-16 H : 1.2-21						70		
A1690 (15.8/91.0 cm ³ /rev)				B : 1.2- 7 C : 1.2-16 H : 1.2-21						70		
A2290 (22.2/91.0 cm ³ /rev)				B : 1.2- 7 C : 1.2-16						70		
A3790 (36.9/91.0 cm ³ /rev)				B : 1.2- 7 C : 1.2-16 H : 1.2-21						None: Keyed Shaft	None: Keyed Shaft	70
A5690 (56.2/91.0 cm ³ /rev)				B : 1.2- 7 C : 1.2-16 H : 1.2-21								70
A16145 (15.8/145 cm ³ /rev)	B : 1.2- 7 C : 1.2-16	60										
A22145 (22.2/145 cm ³ /rev)	B : 1.2- 7 C : 1.2-16	60										
A37145 (36.9/145 cm ³ /rev)	B : 1.2- 7 C : 1.2-16 H : 1.2-21	60										
A56145 (56.2/145 cm ³ /rev)	B : 1.2- 7 C : 1.2-16 H : 1.2-21	60										

★1. Available to supply pump with anti-clockwise rotation. Consult Yuken for details.

Series Piston Pumps – Variable / Fixed Double Pumps

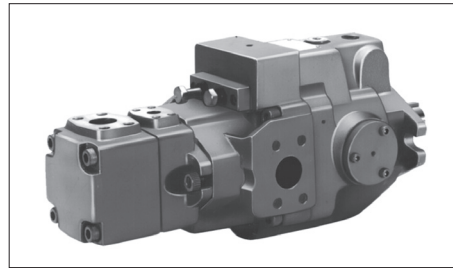

Graphic Symbol

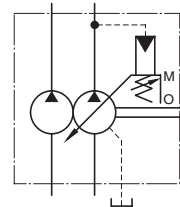

Model Number Designation

A1637	-F	-R	Inboard Pump (Driven End)		Outboard Pump			K	-32
			01	C	-23	A	A		
Series Number	Mounting	Direction of Rotation	Control Type	Pres. Adj. Range MPa	Nominal Displacement cm ³ /rev	Discharge Port Position	Suction Port Position	Shaft Extension	Design Number
A16R1	F: Flange Mtg. L: Foot Mtg.	(Viewed from Shaft End) R: Clockwise* ¹ (Normal)	01: Pressure Compensator Type	B: 1.2- 7 C: 1.2-16 D: 1.2-21	6, 8 10, 12 14, 17 19, 23 25, 31	(Viewed from Shaft End) A: Up	A: Up	K: Keyed Shaft	32
A22R1				B: 1.2- 7 C: 1.2-16					32
A37R1				B: 1.2- 7 C: 1.2-16 D: 1.2-21					32
A56R1				B: 1.2- 7 C: 1.2-16 D: 1.2-21					32
A70R1				B: 1.2- 7 C: 1.5-16 H: 1.8-21 K: 2.0-28					70
A90R1				None: Keyed Shaft				70	
A145R1								60	
A70R2								70	
A90R2								70	
A145R2								60	

*1. Available to supply pump with anti-clockwise rotation. Consult Yuken for details.

Consult Yuken when detailed material such as dimensions figures is required.

Specifications

Model Numbers	Geometric Displacement cm ³ /rev	Operating Pressure MPa		Shaft Speed Range r/min		Approx. Mass kg		
		Rated	Intermittent	Max.	Min.	Flange Mtg.	Foot Mtg.	
A16R1- *R01 *-AAK-32	Outboard Pump	Refer to the following table			1800	750	28.8	31.0
	Inboard Pump	15.8	16	21				
A22R1- *R01 *-AAK-32	Outboard Pump	Refer to the following table			1800	750	28.8	31.0
	Inboard Pump	22.2	16	16				
A37R1- *R01 *-AAK-32	Outboard Pump	Refer to the following table			1800	750	39	43.3
	Inboard Pump	36.9	16	21				
A56R1- *R01 *-AAK-32	Outboard Pump	Refer to the following table			1800	750	47	51.3
	Inboard Pump	56.2	16	21				
A70R1- *R01 *-AA-70	Outboard Pump	Refer to the following table			1800	750	66	78
	Inboard Pump	70.0	25	28				
A90R1- *R01 *-AA-70	Outboard Pump	Refer to the following table			1800	750	82	105
	Inboard Pump	91.0	25	28				
A145R1- *R01 *-AA-60	Outboard Pump	Refer to the following table			1800	750	102	129
	Inboard Pump	145	25	28				
A70R2- *R01 *- *AA-70	Outboard Pump	Refer to the following table			1800	600	72.5	84.5
	Inboard Pump	70.0	25	28				
A90R2- *R01 *- *AA-70	Outboard Pump	Refer to the following table			1800	600	91.5	112
	Inboard Pump	91.0	25	28				
A145R2- *R01 *- *AA-60	Outboard Pump	Refer to the following table			1800	600	112	137
	Inboard Pump	145	25	28				

Geometric Displacement and Max. Pressure of Outboard Pump

Model Numbers	Geometric Displacement cm ³ /rev	Max Pres. MPa	
		Anti-Wear Type	R & O Type
A *R1- *R01 *-6	5.8	21	16
A *R1- *R01 *-8	8.0		
A *R1- *R01 *-10	9.4		
A *R1- *R01 *-12	12.2		
A *R1- *R01 *-14	13.7		
A *R1- *R01 *-17	16.6		
A *R1- *R01 *-19	18.6		
A *R1- *R01 *-23	22.7	17.5	
A *R1- *R01 *-25	25.3	15	15
A *R1- *R01 *-31	31.0	12	12
A *R2- *R01 *-26	26.6	21	14
A *R2- *R01 *-33	33.3		
A *R2- *R01 *-41	41.3		
A *R2- *R01 *-47	47.2	20	
A *R2- *R01 *-53	52.5	18	
A *R2- *R01 *-59	58.2	16	
A *R2- *R01 *-65	64.7	14	

A3H Series High Pressure Variable Displacement Piston Pumps

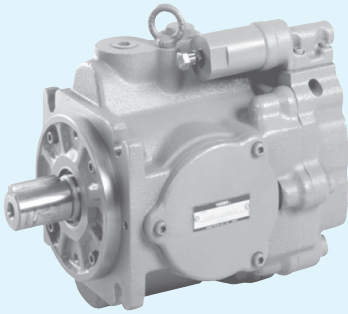

Pressure Compensator Type

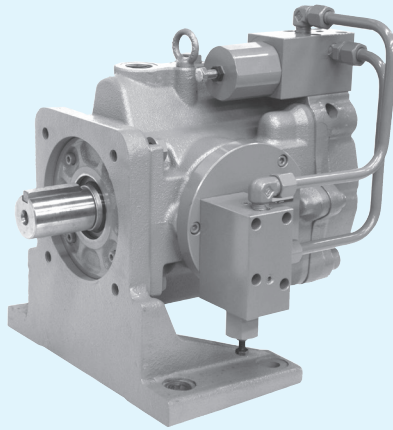

Constant Power (Torque) Control Type

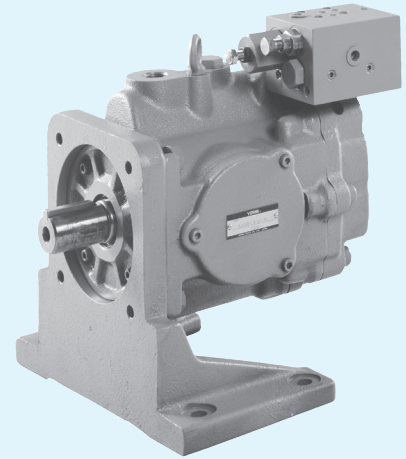

Load Sensing Type

“A3H” Series High Pressure Variable Displacement Piston Pumps

Pump Type	Graphic Symbol	Graphic Displacement cm ³ /rev								Maximum Operating Pressure MPa	Page		
		1	2	5	10	20	50	100	200			300	
A3H Series High Pressure Variable Displacement Piston Pumps Single Pump★					A3H16						35	A-114	
					A3H37								
						A3H56							
						A3H71							
						A3H100							
						A3H145							
						A3H180							

★ Four control types are available such as pressure compensator type. Refer to page A-115.

Hydraulic Fluids

■ **Hydraulic Fluids**

Use petroleum base oils such as anti-wear type hydraulic oils or R & O (Rust and Oxidation inhibitor) type hydraulic oils equivalent to ISO VG-32 or 46.

The recommended viscosity range is from 20 to 400 mm²/s and temperature range is from 0 to 60 °C, both of which have to be satisfied for the use of the above hydraulic oils.

■ **Control of Contamination**

Due caution must be paid to maintaining control over contamination of the operating oil which can otherwise lead to breakdowns and shorten the life of the unit. Please maintain the degree of contamination within NAS Grade 10.

The suction port must be equipped with at least a 100 μm (150 mesh) reservoir type filter and the return line must have a line filter of under 10 μm.

Instructions

■ **Mounting**

When installing the pump the filling port should be positioned upwards.

■ **Alignment of Shaft**

Employ a flexible coupling whenever possible, and avoid any stress from bending or thrust.

Maximum permissible misalignment is less than 0.1 mm TIR and maximum permissible misangular is less than 0.2°.

■ **Suction Pressure**

Permissible suction pressure at suction port of the pump is between -16.7 and +50 kPa. In case of the speed is over 1800 r/min, adjust the pressure 0 to +50 kPa.

For piping to the suction port, use the pipes of the same diameter as that of the specified pipe flange to be used.

Make sure that the height of the pump suction port is within one meter from the oil level in the reservoir.

■ **Hints on Piping**

When using steel pipes for the suction or discharge ports, excessive load from the piping to the pump generates excessive noise.

Whenever there is fear of excessive load, please use rubber hoses.

■ **Suction Piping**

In case the pump is installed above the oil level, the suction piping and suction line filter should be located lower than the pump position to prevent air in the suction line.

■ **Drain Piping**

Install drain piping according to the chart and ensure that pressure within the pump housing should be maintained at a normal pressure of less than 0.1 MPa and surge pressure of less than 0.5 MPa.

Length of piping should be less than 1 m, and the pipe end should be submerged in oil.

[Recommended Drain Piping Size]

Model	Fitting Size	Inside Dia. of Pipe
A3H16 A3H37	1/2	12 mm or more
A3H56 A3H180	3/4	19 mm or more

■ **Safety Valve**

When delivery line is blocked suddenly, surge pressure is occurred so a safety valve should be set in the circuit to eliminate any damage on equipment and piping.

■ **Bleeding Air**

It may be necessary to bleed air from pump case and outlet line to remove causes of vibration.

■ **Starting**

Before first starting, fill pump case with clean operating oil via the fill port.

In order to avoid air blockage when first starting, adjust the control valves so that the discharged oil from the pump is returned direct to the tank or the actuator moves in a free load.

[Volume of Pre-fill Oil Required]

Model	Volume cm ³
A3H16	400
A3H37	700
A3H56	900
A3H71	1300
A3H100	1700
A3H145	2400
A3H180	3200

■ Setting Discharge Pressure and Delivery

At the time of shipment, the unit has been preset to maximum delivery and minimum discharge pressure. Adjust the preset delivery and pressure to meet your system requirements.

● Adjustment of Discharge Pressure

Turning the adjustment screw clockwise, increases pressure.

Volume adjusted by each full turn of the pressure adjustment screw

Model Numbers	Adjustment Volume MPa
A3H16/A3H37/A3H56-01	5.5
A3H71/A3H100/A3H145-01	6.3
A3H180-01	5.7

● Adjustment of Delivery

Turning the flow adjustment screw clockwise, decreases delivery.

The minimum adjustable flow and adjustable volume of each full turn of the delivery adjustment screw

Model Numbers	Adjustable volume with each full turn of the adjustment screw cm ³ /rev	Minimum Adjustable Flow cm ³ /rev
A3H16	1.4	8
A3H37	3.3	16
A3H56	4.2	35
A3H71	4.9	45
A3H100	6.2	63
A3H145	9.4	95
A3H180	10.3	130

■ Flow Adjustment Screw Protrusion Length "L" vs. Geometric Displacement (Reference)

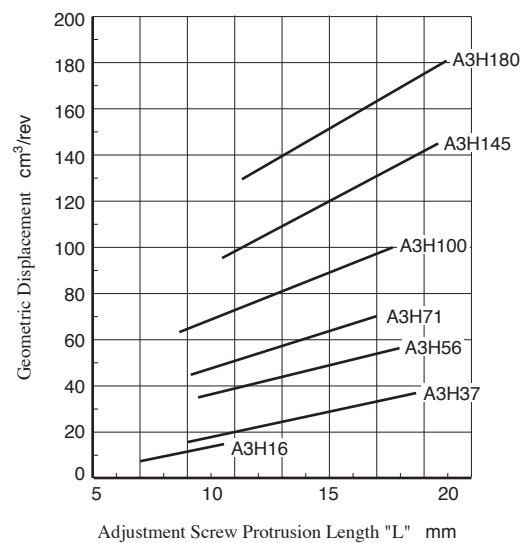
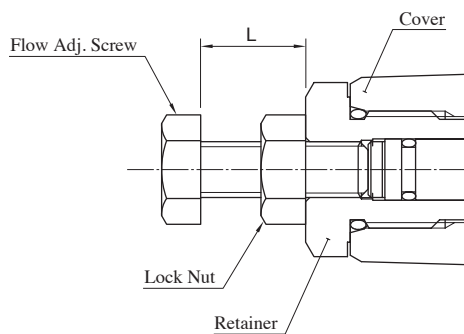

A3H Series High Pressure Variable Displacement Piston Pumps

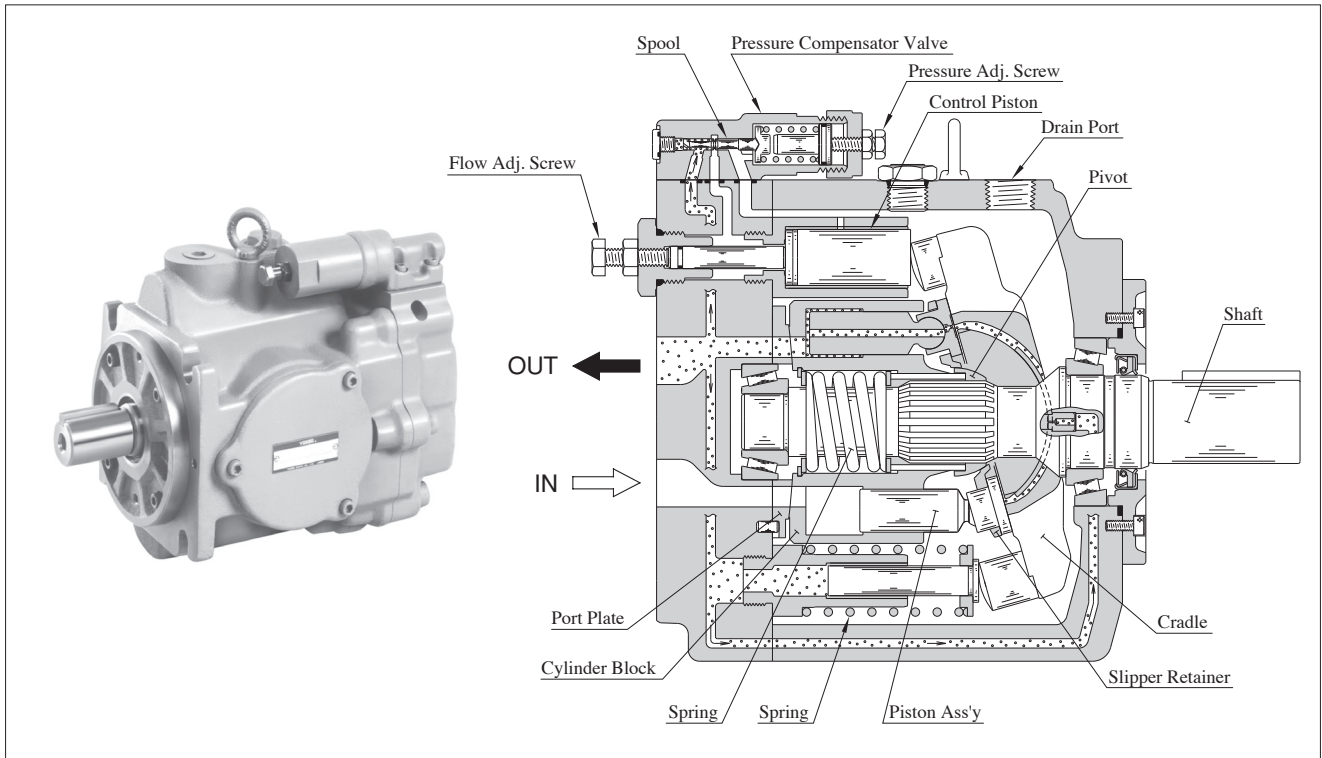

Control Type

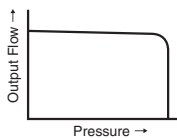
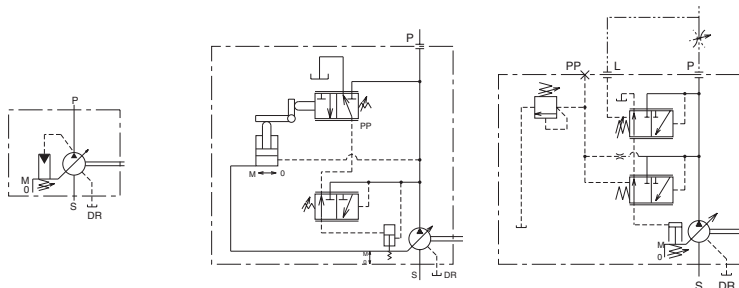
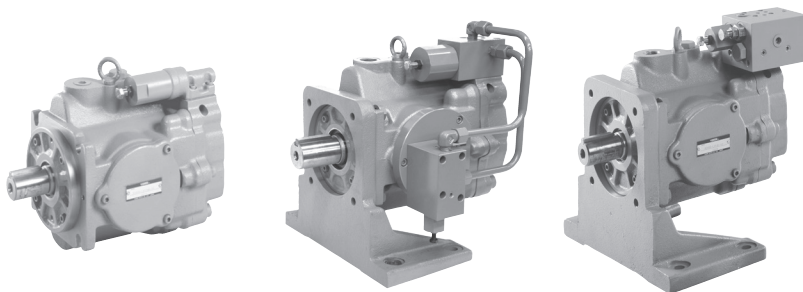

"01" Pressure Compensator Type

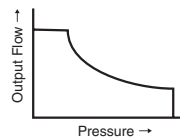

"09" Constant Power Control Type

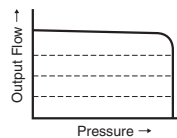

"14" Load Sensing Type

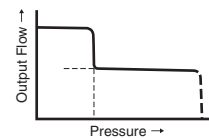

"55" Simple Two-Pressure Two-Flow Control Type

Features

- High performance at maximum pressure 35 MPa
Volumetric efficiency is over 95% and overall efficiency is more than 90% at 1800 r/min.

"A3H37" Type Performance Characteristics

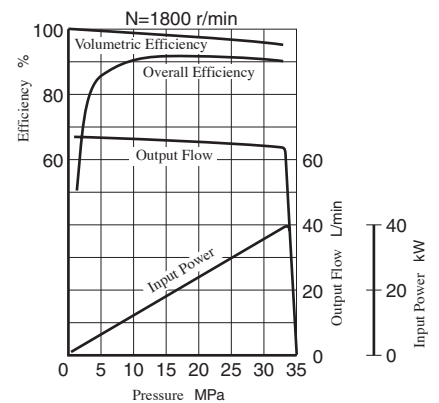

Compact size

A3H series are compact in size because output / mass ratio is large.

Control Type

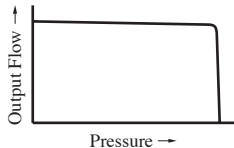
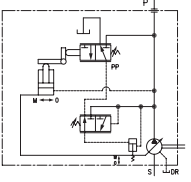
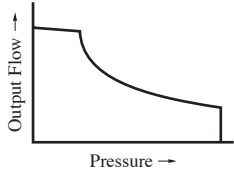
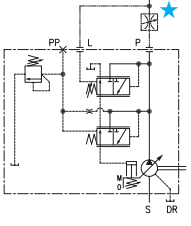
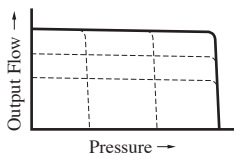
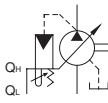
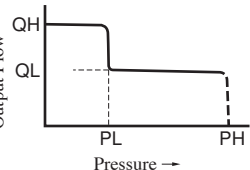
Control Type	Graphic Symbols	Performance Characteristics	Explanation	Page
"01" Pressure Compensator Type			When the system pressure increases and comes close to the preset cut-off pressure, the pump flow decreases automatically while maintaining the set pressure as it is.	A-116
"09" Constant Power (Torque) Control Type			<ul style="list-style-type: none"> This type of control can control the pump input power according to the motor output. When the system pressure increases, the pump swash plate tilt angle (output flow) decreases, in correspondence to predetermined shaft input values. This type of control can enable one pump to act as two pumps (low-pressure and large-flow/high-pressure and small-flow). Therefore, the motor capacity can be reduced. 	A-135
"14" Load Sensing Type			<ul style="list-style-type: none"> This is an energy-saving type control which maintains the pump flow and load pressure at the absolute minimum necessary level to operate the actuator. This type of control automatically regulates the output flow so that the inlet-outlet differential pressure of the flow control valve at the output side is constant. To do so, the load pressure must be introduced to the load sensing port "L" of the pump through the external piping. This type of control provides the remote control of the full cut-off pressure by connecting a remote control relief valve to the pilot port "PP". 	A-141
"55" Simple Two-Pressure Two-Flow Control Type			<ul style="list-style-type: none"> This type of control enables one pump to act as two pumps (low-pressure and large-flow/high-pressure and small-flow-rate). Therefore, the motor capacity can be reduced. When the system pressure increases near the preset "PL" pressure due to the load increase, the pump flow automatically decreases to "QL." This type of control is suitable for an application like the press, where switching from rapid advance to feed is required just when the press (pressurizing) starts. The PH pressure can be remote-controlled with a separately located relief valve. With this type of control, it is easy to change the applied pressure setting when materials or shapes of the press are changed. 	A-147

★ A flow control valve is not included with the pump. Install the valve separately.

Availability of Control Type

Mark "○" in the table below refers to standard model.

Model Numbers	Geometric Displacement cm ³ /rev	"01" Pressure Compensator Type	"09" Constant Power (Torque) Control Type	"14" Load Sensing Type	"55" Simple Two-Pressure Two-Flow Control Type
A3H 16	16.3	○		○	○
A3H 37	37.1	○	○	○	○
A3H 56	56.3	○	○	○	○
A3H 71	70.7	○	○	○	○
A3H100	100.5	○	○	○	○
A3H145	145.2	○	○	○	○
A3H180	180.7	○	○	○	○

A3H Series High Pressure Variable Displacement Piston Pumps, Pressure Compensator Type

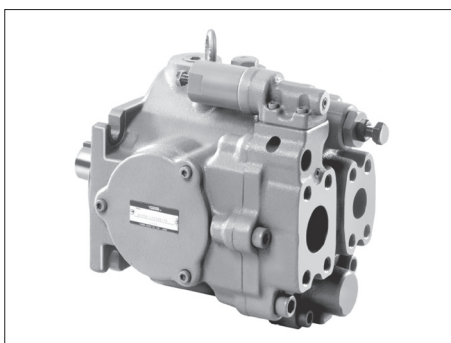

Graphic Symbol

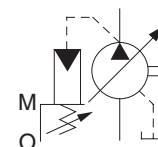

Specifications

Model Numbers	Geometric Displacement cm ³ /rev	Minimum Adj. Flow cm ³ /rev	Operating Pressure MPa		Shaft Speed Range r/min		Approx. Mass kg	
			Rated ^{★1}	Intermittent	Max. ^{★2}	Min.	Flange Mtg.	Foot Mtg.
A3H 16- *R01KK-10	16.3	8.0	28	35	3600	600	14.5	23.4
A3H 37- *R01KK-10	37.1	16.0			2700	600	19.5	27.0
A3H 56- *R01KK-10	56.3	35.0			2500	600	25.7	33.2
A3H 71- *R01KK-10	70.7	45.0			2300	600	35.0	42.5
A3H100- *R01KK-10	100.5	63.0			2100	600	44.9	72.9
A3H145- *R01KK-10	145.2	95.0			1800	600	60.0	88.0
A3H180- *R01KK-10	180.7	130.0			1800	600	70.4	98.4

★1. Consult Yuken when pump is used over rated pressure because there is a restriction on operating condition.

★2. The maximum shaft speeds shown in the above table are at suction pressure 0 kPa.

★3. The table above shows specifications for using petroleum based oils.

Pumps (customized design) for special fluids are also available. Their operating pressure and maximum shaft speed however differ from the values in the table above depending on the fluid type.

Range of operating temperature and viscosities may differ from those of petroleum based oils due to their characteristics.

Specifications and Design Numbers for Special Fluids

Type of Fluids	Operating Pressure MPa		Allowable Maximum Shaft Speed r/min		Temperature Range °C	Viscosity Range mm ² /s	Design Numbers for Special Fluid
	Rated	Intermittent	Rated	Max.			
Water-Glycols	21	21	1200	(1800) ^{★1}	0 - 50	20 - 200	1030
Phosphate Ester Type	21	21	1200	(1800) ^{★1}	0 - 60		1006
Polyol Ester Type	21	25	1200	1800	0 - 60	20 - 200	10450

★1. As the specific gravities of water-glycol fluids and phosphate ester type fluids are higher than one, an overhead reservoir is required when pumps are operated at 1500 r/min or more.

Model Number Designation

A3H16	-F	R	01	K	K	-10
Series Number	Mounting	Direction of Rotation	Control Type	Pres. Adj. Range MPa	Shaft Extension	Design Number
A3H16 (16.3 cm ³ /rev)	F: Flange Mtg. L: Foot Mtg.	(Viewed from) Shaft End R: Clockwise (Normal)	01: Pressure Compensator Type	K: 5 - 35	K: Keyed Shaft	10
A3H37 (37.1 cm ³ /rev)						10
A3H56 (56.3 cm ³ /rev)						10
A3H71 (70.7 cm ³ /rev)						10
A3H100 (100.5 cm ³ /rev)						10
A3H145 (145.2 cm ³ /rev)						10
A3H180 (180.7 cm ³ /rev)						10

Pipe Flange Kits

Pipe flange kits are available. When ordering, specify the kit number from the table below.

Pump Model Numbers	Name of Port	Threaded Connection	Socket Welding	Butt Welding
A3H16- *R01	Suction	F5-08-A-10	F5-08-B-10	F5-08-C-10
	Discharge	F6-06-A-M-10 ^{★1}	F6-06-B-M-10	—
A3H37- *R01	Suction	F5-10-A-10	F5-10-B-10	F5-10-C-10
	Discharge	F6-08-A-M-10 ^{★1}	F6-08-B-M-10	—
A3H56- *R01	Suction	F5-12-A-10	F5-12-B-10	F5-12-C-10
	Discharge	F6-08-A-M-10 ^{★1}	F6-08-B-M-10	—
A3H71- *R01	Suction	F5-16-A-10	F5-16-B-10	F5-016-C-10
	Discharge	F6-10-A-M-10 ^{★1}	F6-10-B-M-10	—
A3H100- *R01 A3H145- *R01	Suction	F5-20-A-10	F5-20-B-10	F5-20-C-10
	Discharge	F6-10-A-M-10 ^{★1}	F6-10-B-M-10	—
A3H180- *R01	Suction	F5-24-A-10	F5-24-B-10	—
	Discharge	F6-12-A-M-10 ^{★1}	F6-12-B-M-10	—

★1. These flanges are with tapered threaded port, maximum pressure is restricted at 31 MPa.

● Details of the pipe flange kits are shown on pages A-258 and A-259.

Response Characteristics Change in Accordance with Circuits and Operating Conditions.

■ The Circuit and Conditions

● Circuit

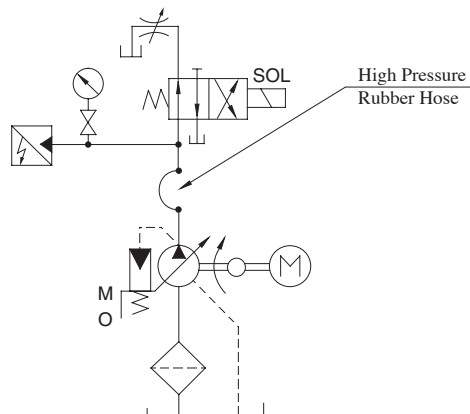

● Size of High Pressure Rubber Hose

Model	High Pressure Rubber Hose
A3H16	3/4B × 1500 mm
A3H37/56/71	3/4B × 2000 mm
A3H100/145	1-1/4B × 2000 mm
A3H180	1-1/4B × 2500 mm

● Conditions

Drive Speed : 1500 r/min
 Hydraulic Fluid : ISO VG32 Oil
 Oil Temperature: 40°C [Viscosity 32 mm²/s]

■ Result of Measurement

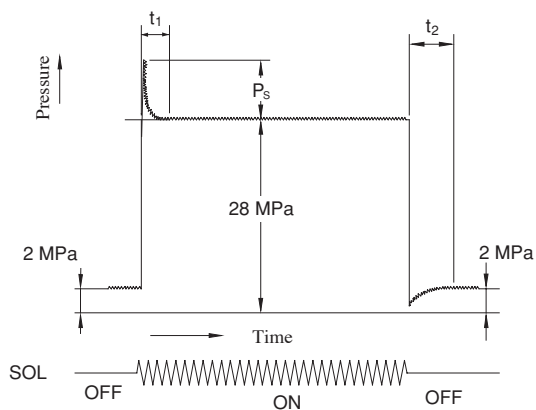

Model	Response Time ms		P _s Overshoot Pres. MPa
	t ₁	t ₂	
A3H 16	30	140	2.5
A3H 37	40	80	3.5
A3H 56	50	90	7.5
A3H 71	50	140	10.0
A3H100	70	170	11.0
A3H145	70	180	12.5
A3H180	70	220	12.0

Typical Performance Characteristics of Type **A3H16** at Viscosity 32 mm²/s [ISO VG32 Oils, 40°C]

Performance Characteristic Curve

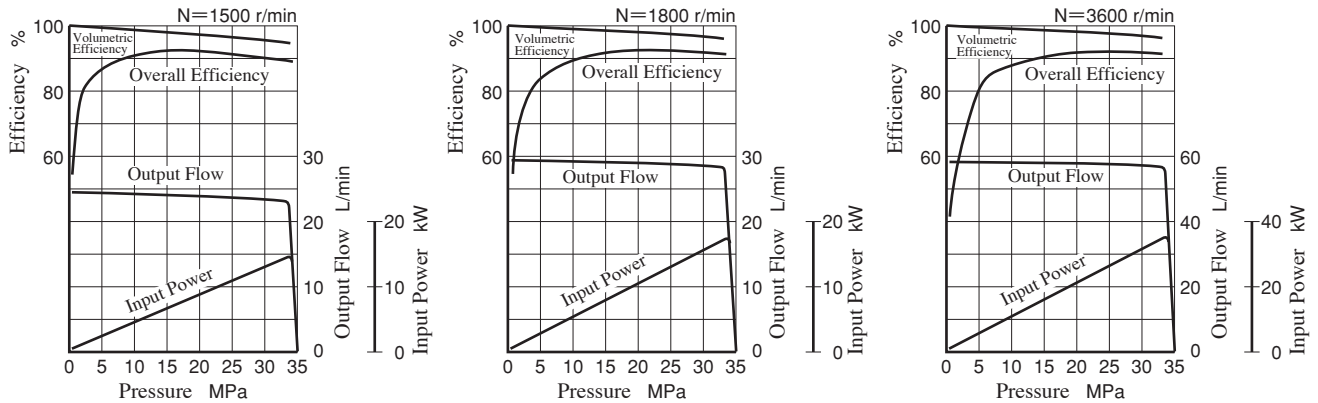

Input Power

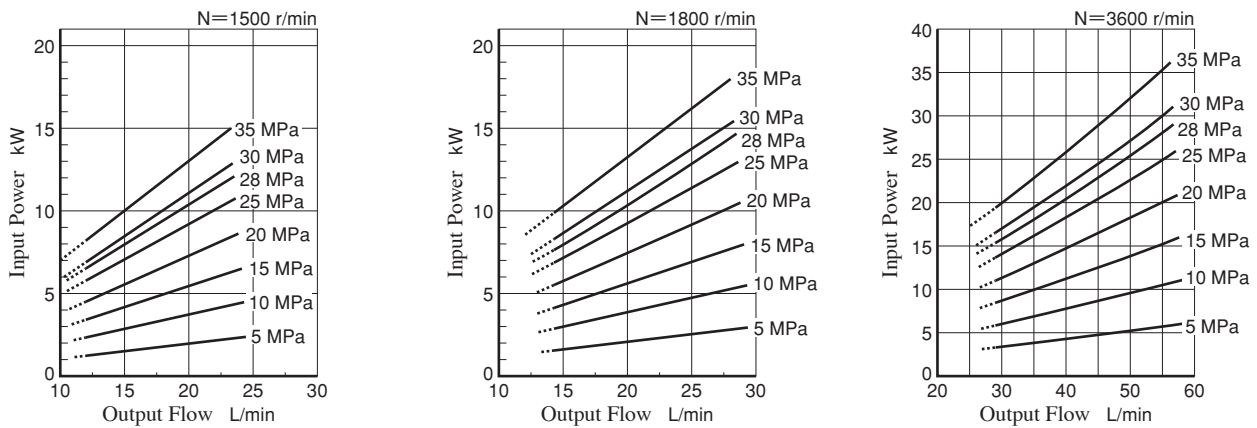

Note) The dotted line in the graph indicates less than minimum adjustable flow.

Full Cut-off Power

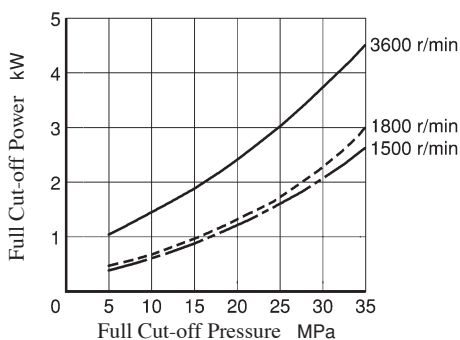

Drain

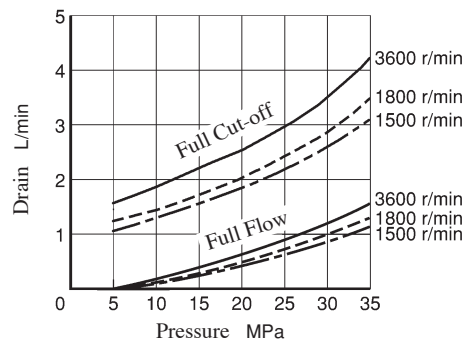

Noise Level [One meter horizontally away from pump head cover]

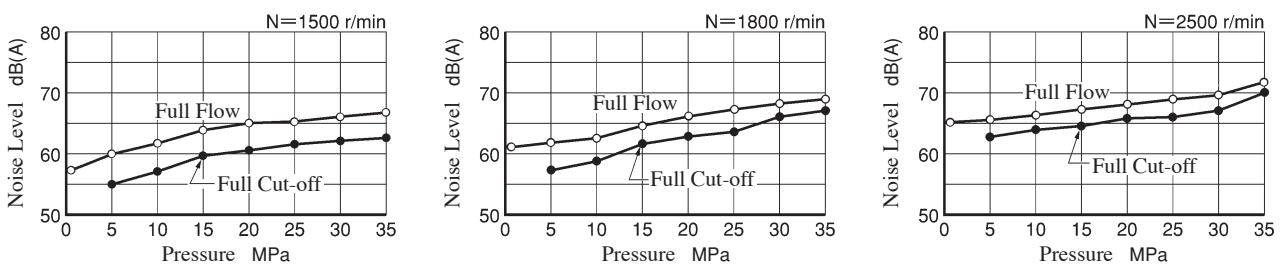

Typical Performance Characteristics of Type **A3H37** at Viscosity 32 mm²/s [ISO VG32 Oils, 40°C]

Performance Characteristic Curve

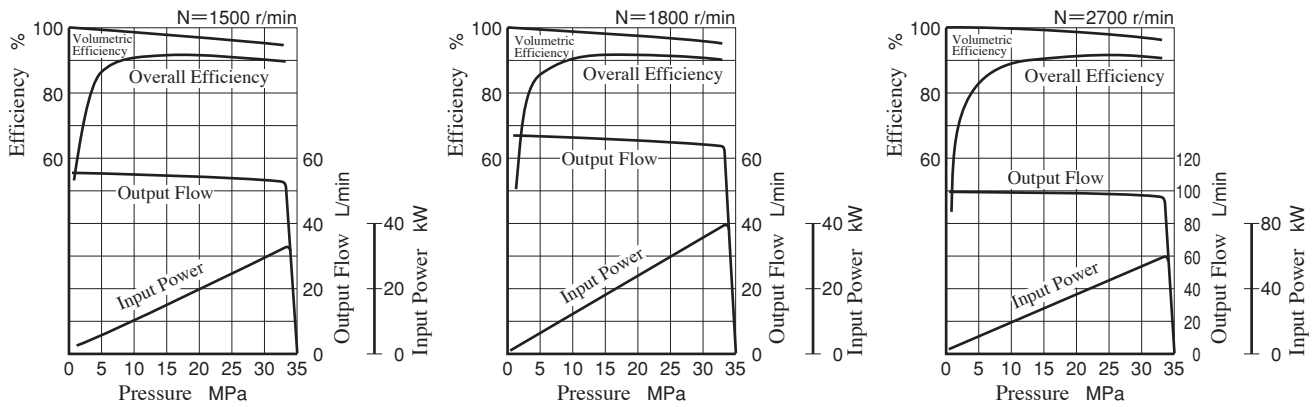

Input Power

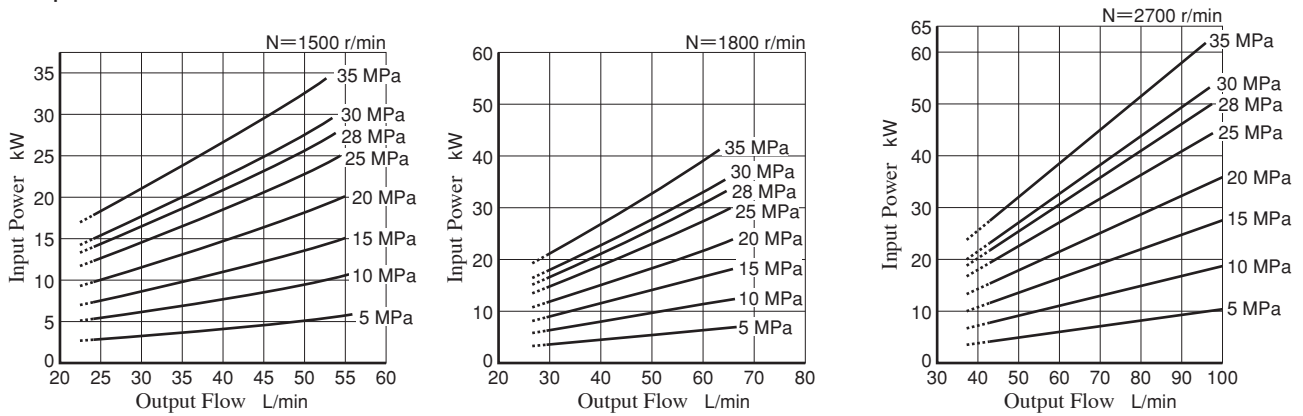

Note) The dotted line in the graph indicates less than minimum adjustable flow.

Full Cut-off Power

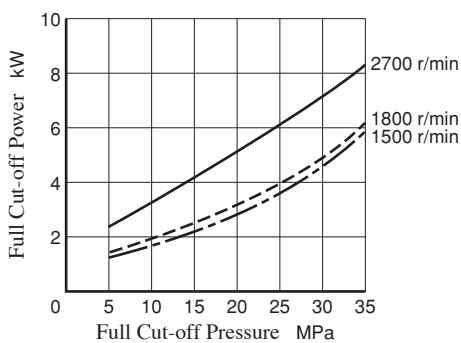

Drain

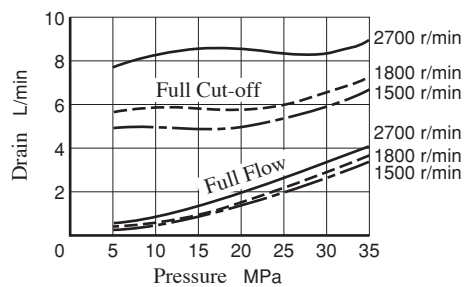

Noise Level [One meter horizontally away from pump head cover]

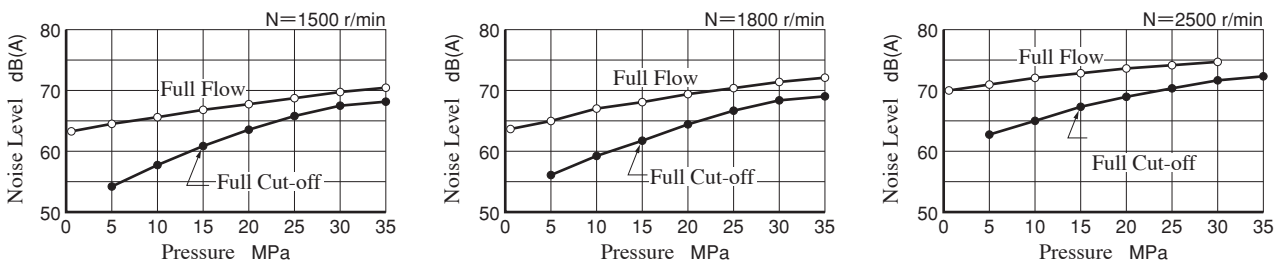

Typical Performance Characteristics of Type **A3H56** at Viscosity 32 mm²/s [ISO VG32 Oils, 40°C]

Performance Characteristic Curve

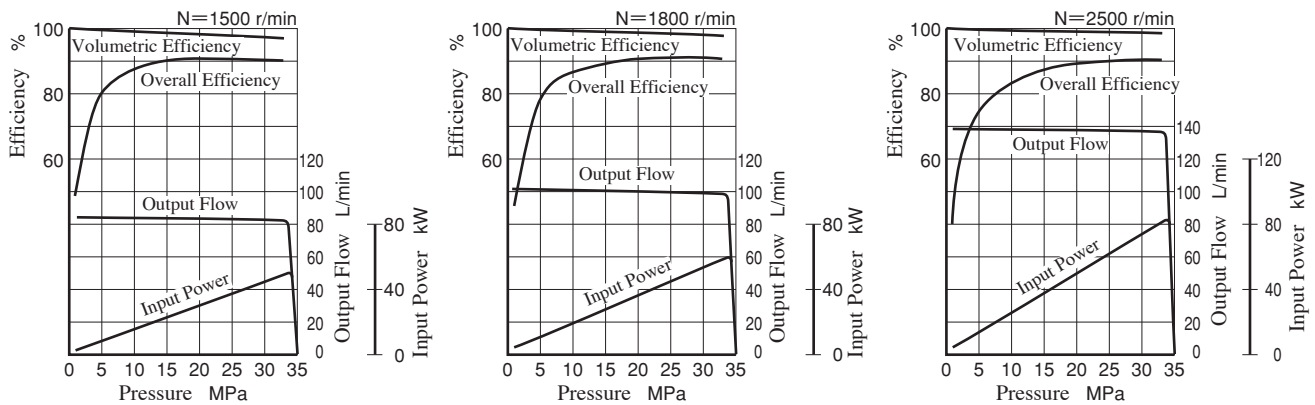

Input Power

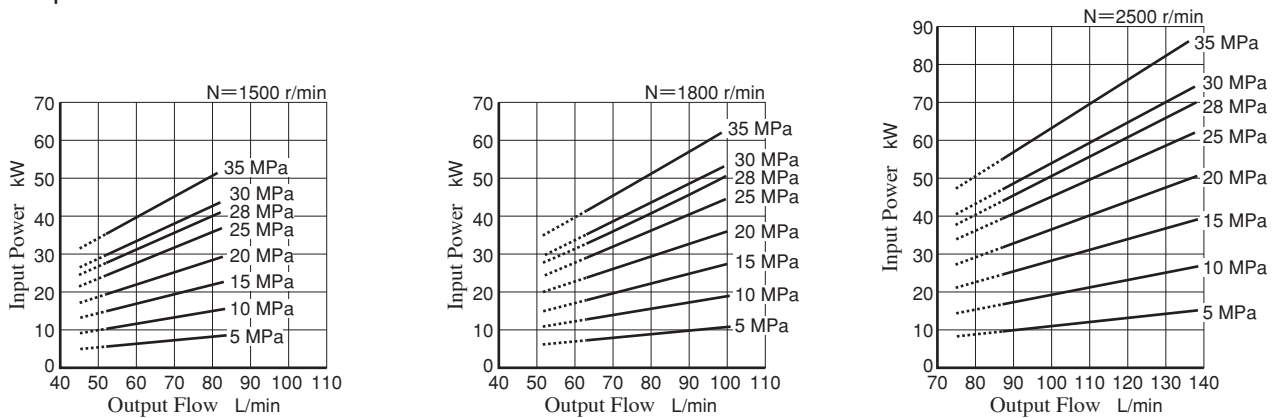

Note) The dotted line in the graph indicates less than minimum adjustable flow.

Full Cut-off Power

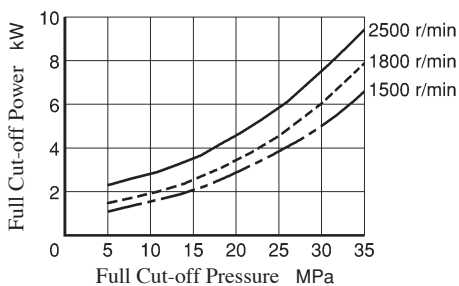

Drain

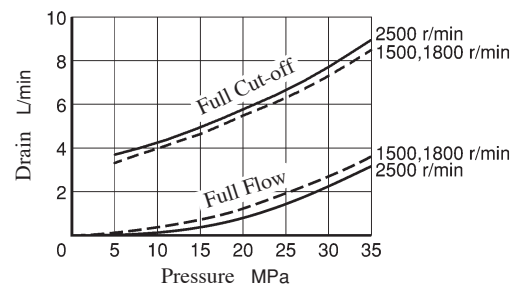

Noise Level [One meter horizontally away from pump head cover]

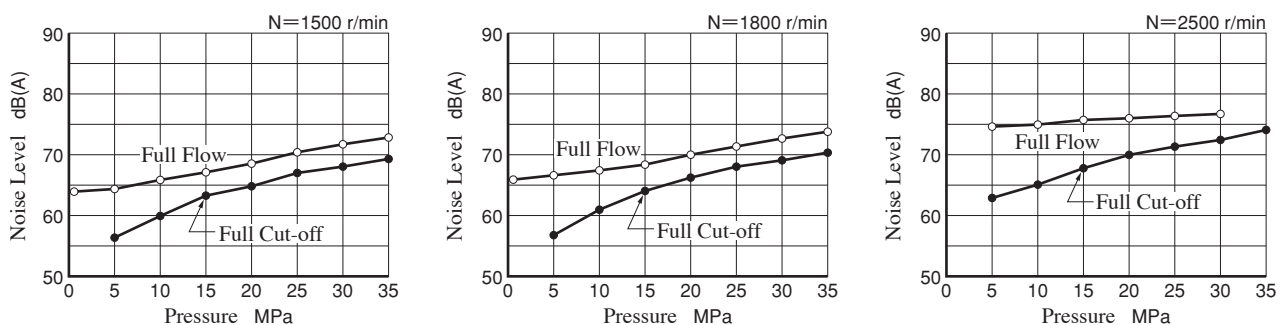

Typical Performance Characteristics of Type **A3H71** at Viscosity 32 mm²/s [ISO VG32 Oils, 40°C]

Performance Characteristic Curve

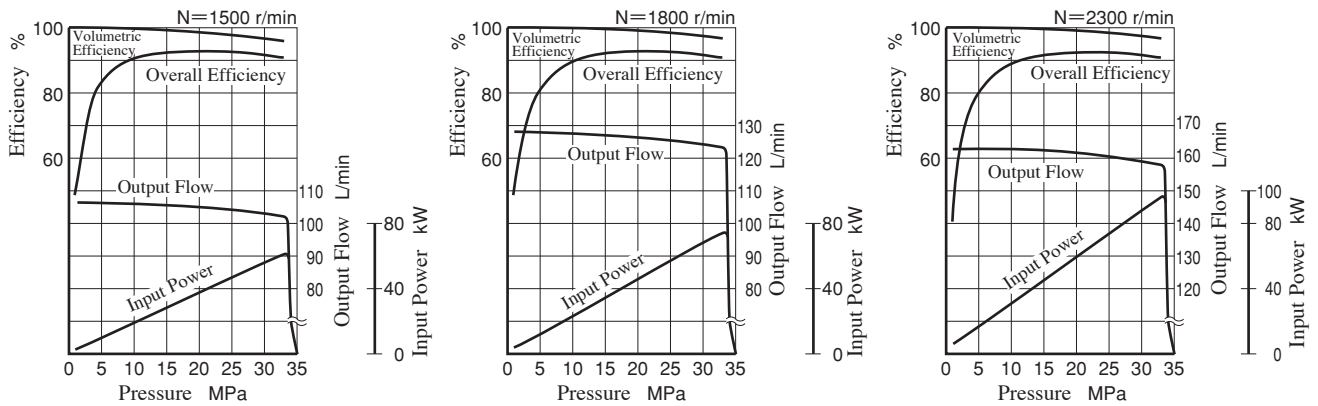

Input Power

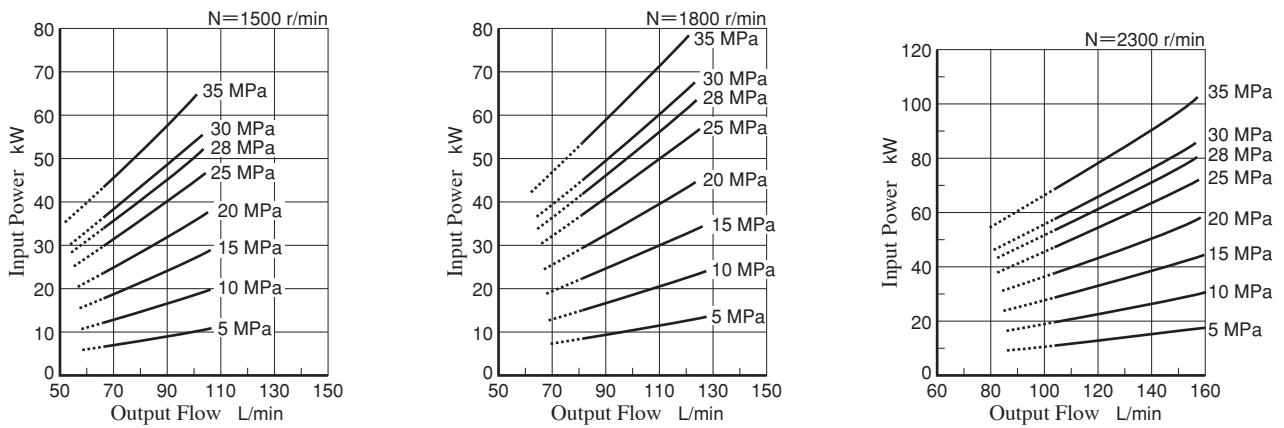

Note) The dotted line in the graph indicates less than minimum adjustable flow.

Full Cut-off Power

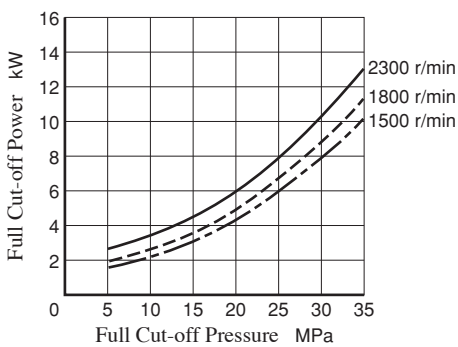

Drain

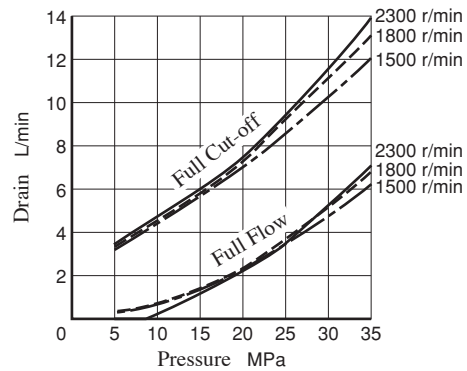

Noise Level [One meter horizontally away from pump head cover]

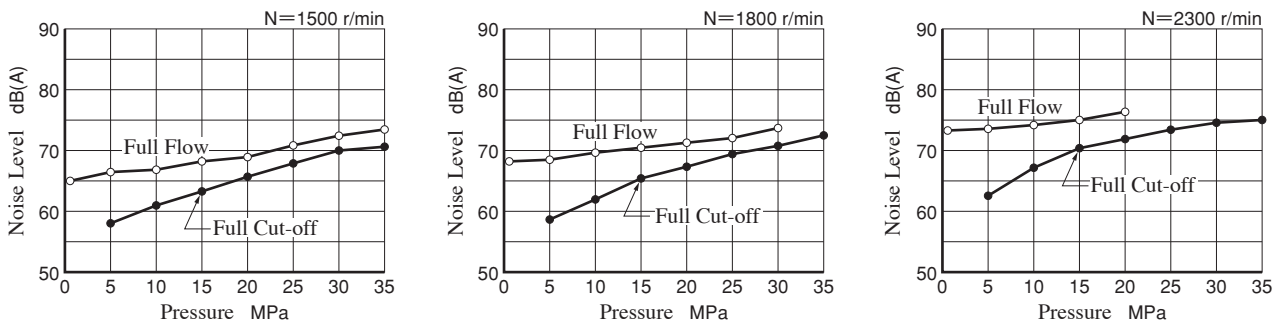

Typical Performance Characteristics of Type **A3H100** at Viscosity 32 mm²/s [ISO VG32 Oils, 40°C]

Performance Characteristic Curve

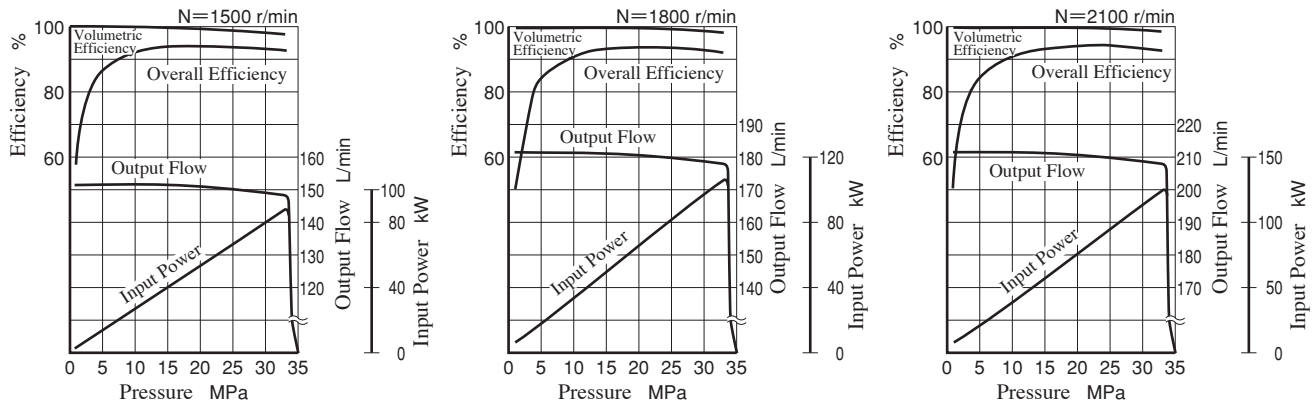

Input Power

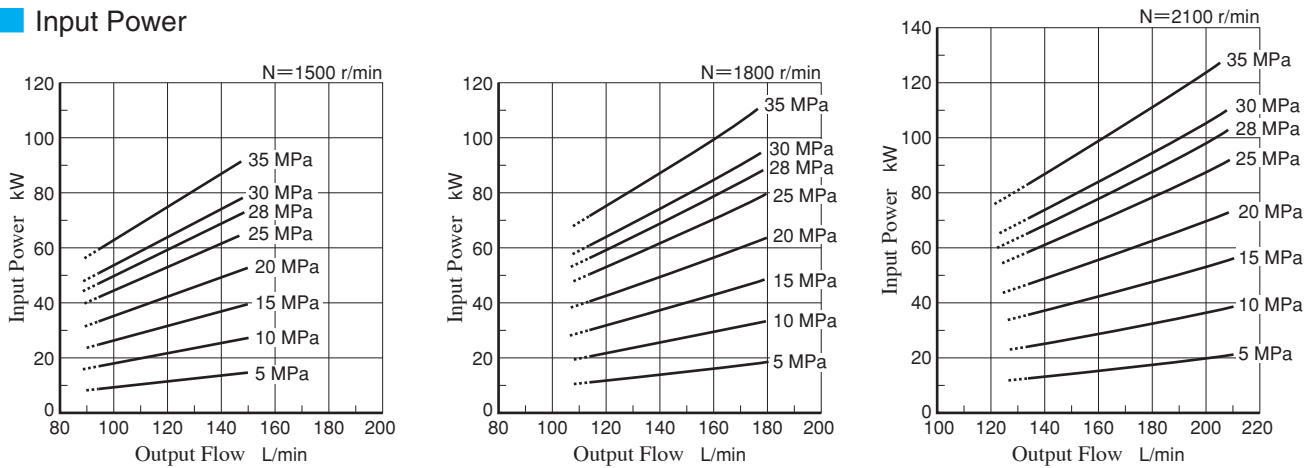

Note) The dotted line in the graph indicates less than minimum adjustable flow.

Full Cut-off Power

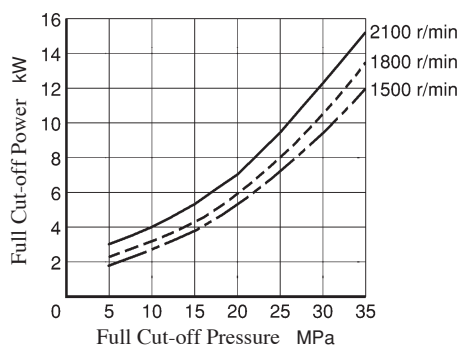

Drain

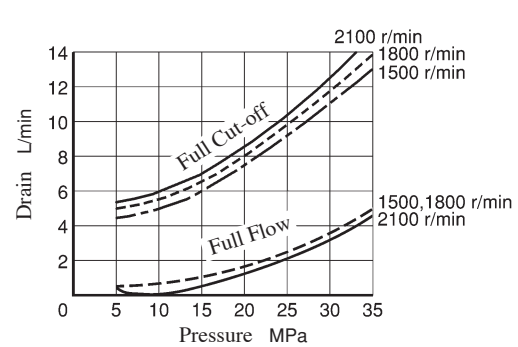

Noise Level [One meter horizontally away from pump head cover]

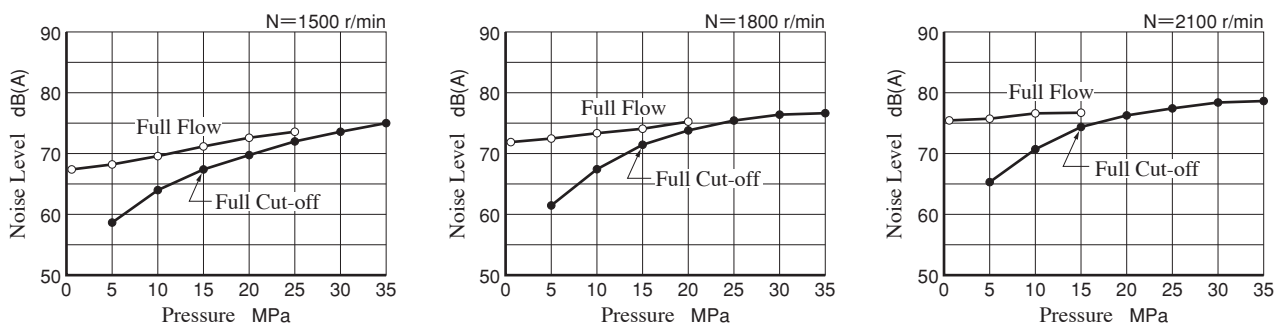

Typical Performance Characteristics of Type **A3H145** at Viscosity 32 mm²/s [ISO VG32 Oils, 40°C]

■ Performance Characteristic Curve

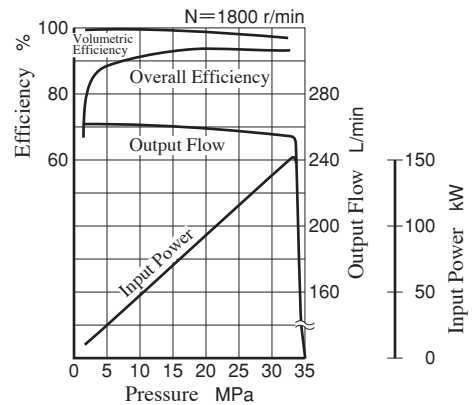
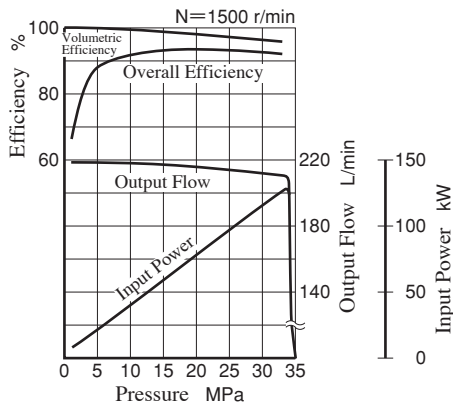

■ Input Power

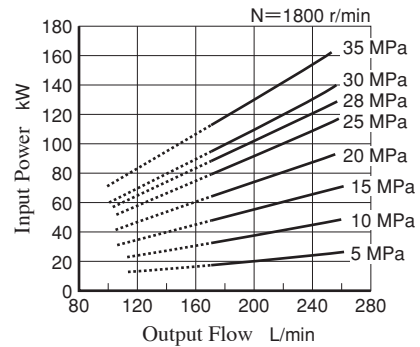
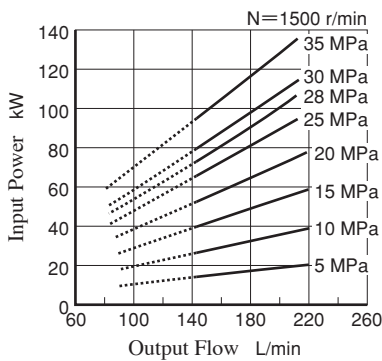

Note) The dotted line in the graph indicates less than minimum adjustable flow.

■ Full Cut-off Power

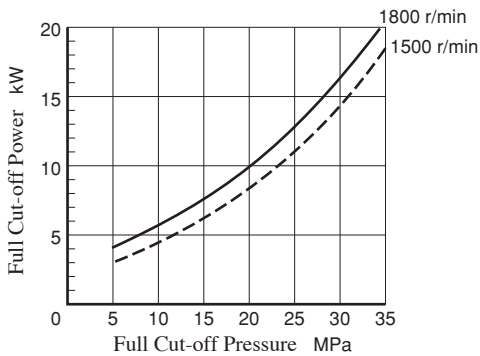

■ Drain

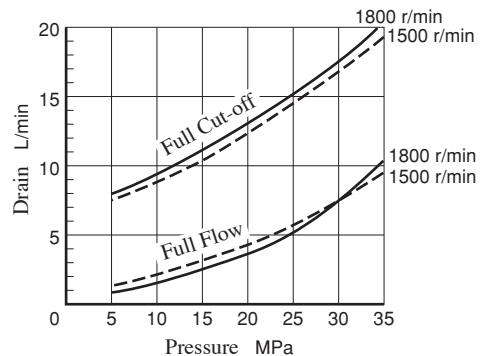

■ Noise Level [One meter horizontally away from pump head cover]

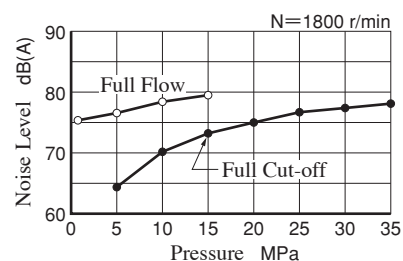
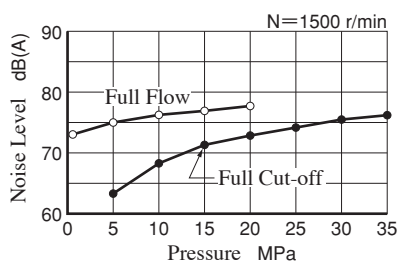

Typical Performance Characteristics of Type **A3H180** at Viscosity 32 mm²/s [ISO VG32 Oils, 40°C]

Performance Characteristic Curve

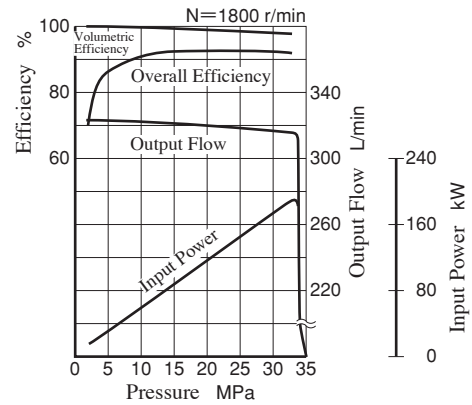
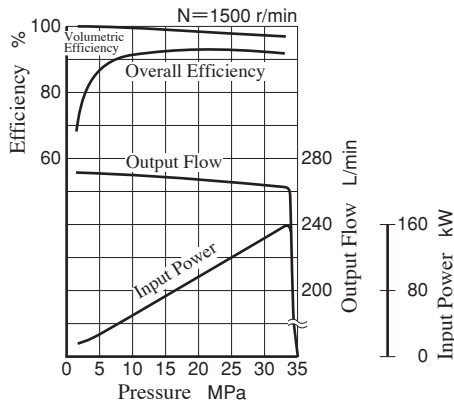

Input Power

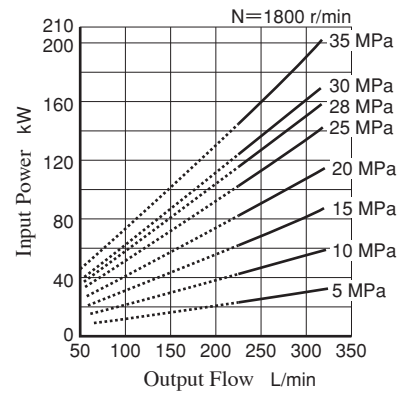
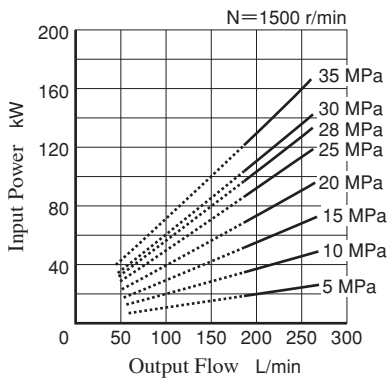

Note) The dotted line in the graph indicates less than minimum adjustable flow.

Full Cut-off Power

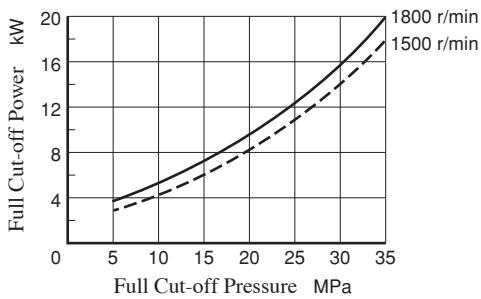

Drain

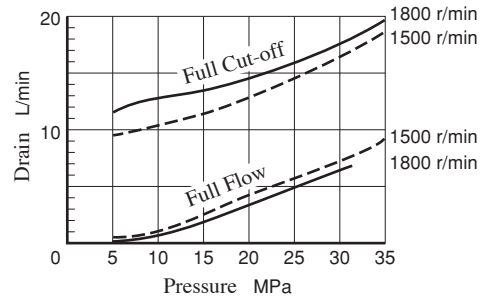

Noise Level [One meter horizontally away from pump head cover]

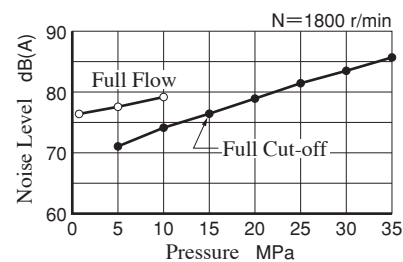
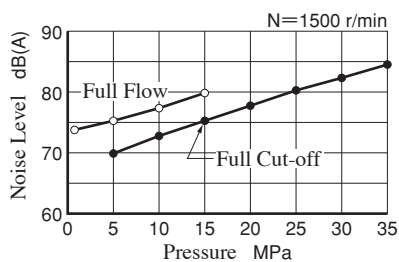

Flange Mtg. : A3H16-FR01KK

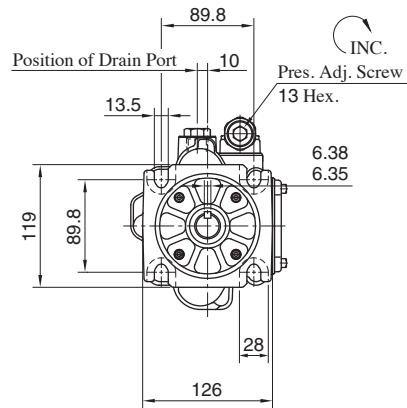
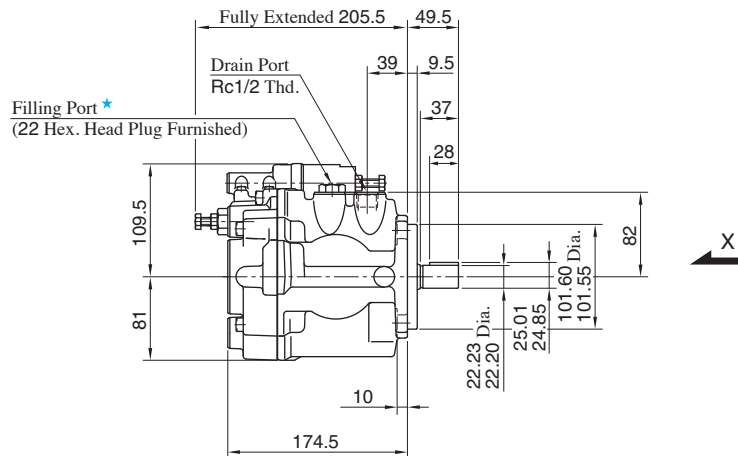
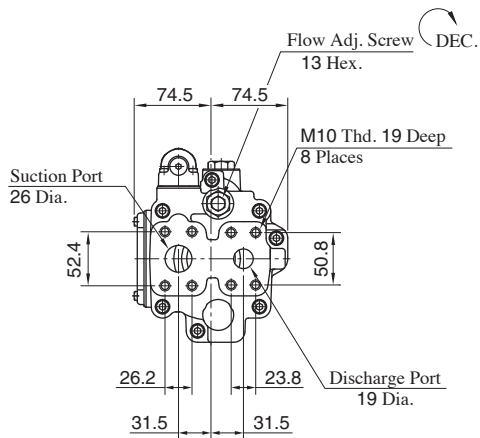

★ Install the pump so that the “Filling Port” is at the top.

View Arrow X

Foot Mtg. : A3H16-LR01KK

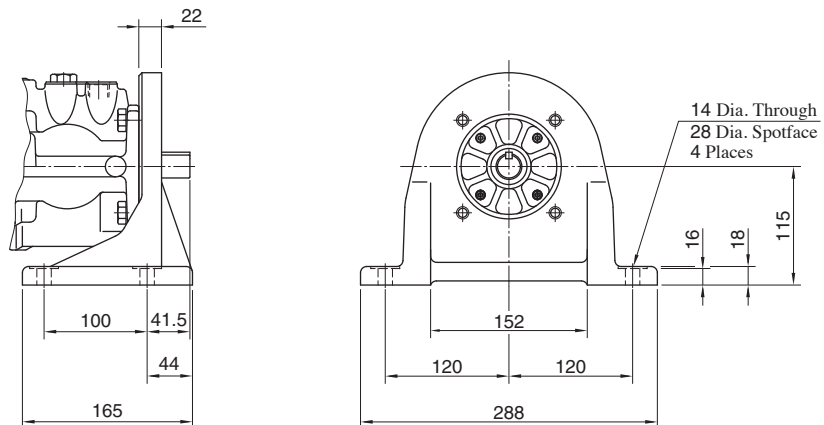

● For other dimensions, refer to “Flange Mtg.”.

Flange Mtg. : A3H37-FR01KK

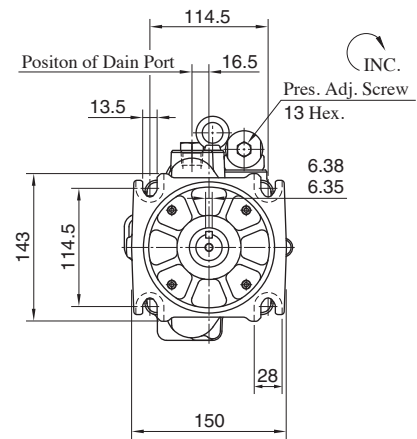
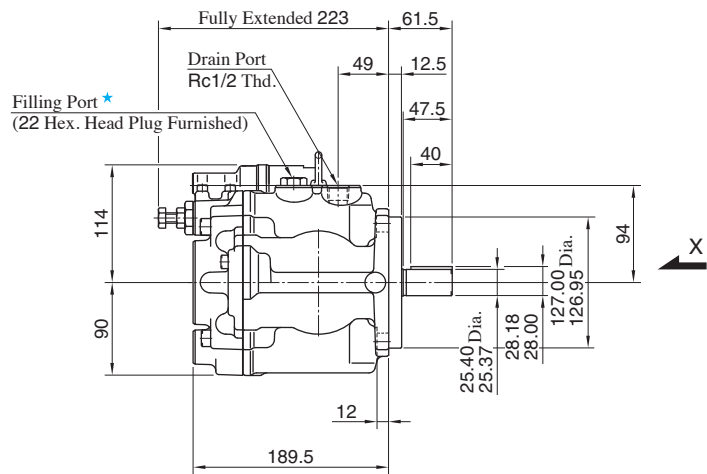
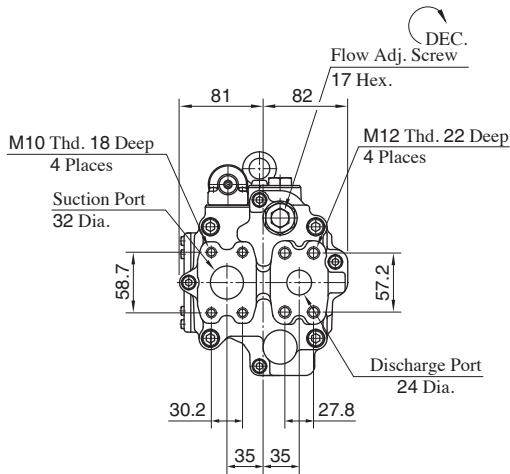

View Arrow X

★ Install the pump so that the “Filling Port” is at the top.

Foot Mtg. : A3H37-LR01KK

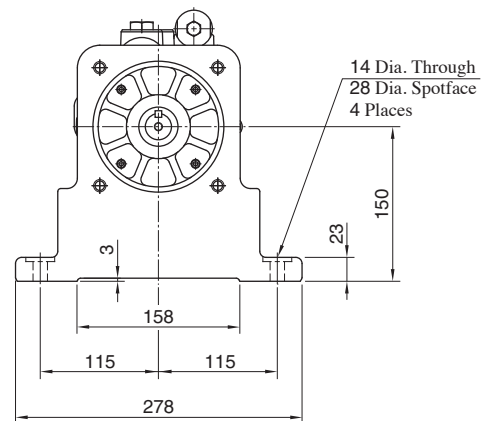
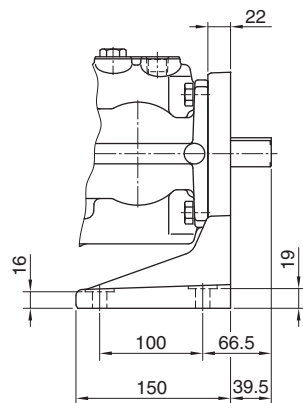

● For other dimensions, refer to “Flange Mtg.”.

Flange Mtg. : A3H56-FR01KK

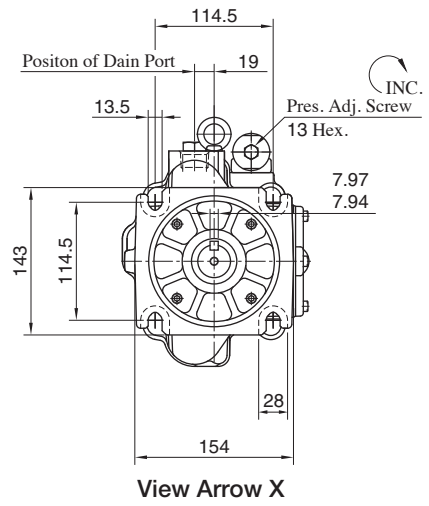
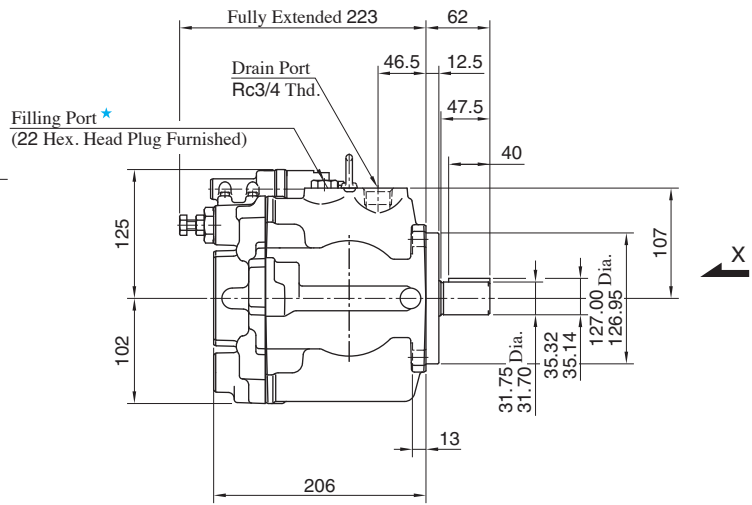
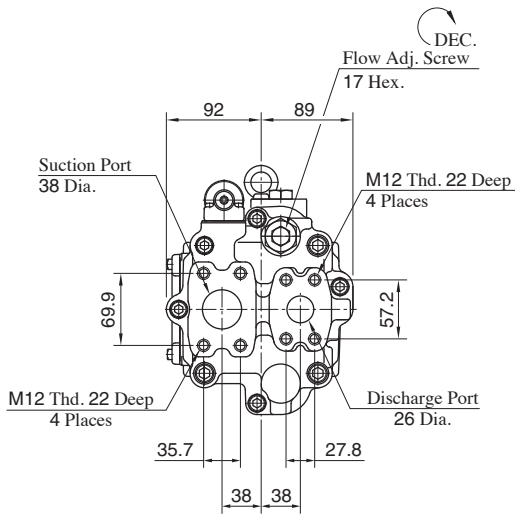

★ Install the pump so that the “Filling Port” is at the top.

Foot Mtg. : A3H56-LR01KK

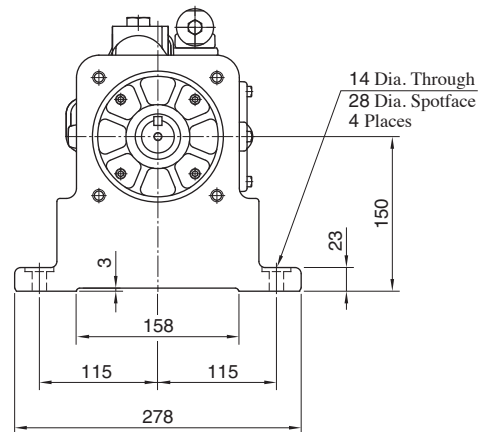
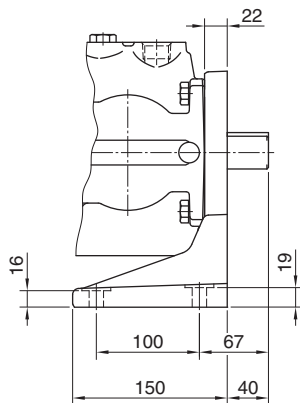

● For other dimensions, refer to “Flange Mtg.”.

Flange Mtg. : A3H71-FR01KK

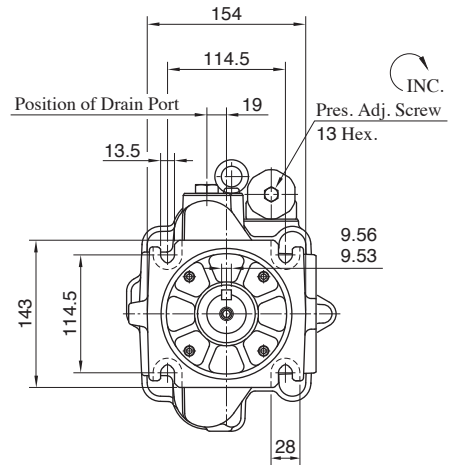
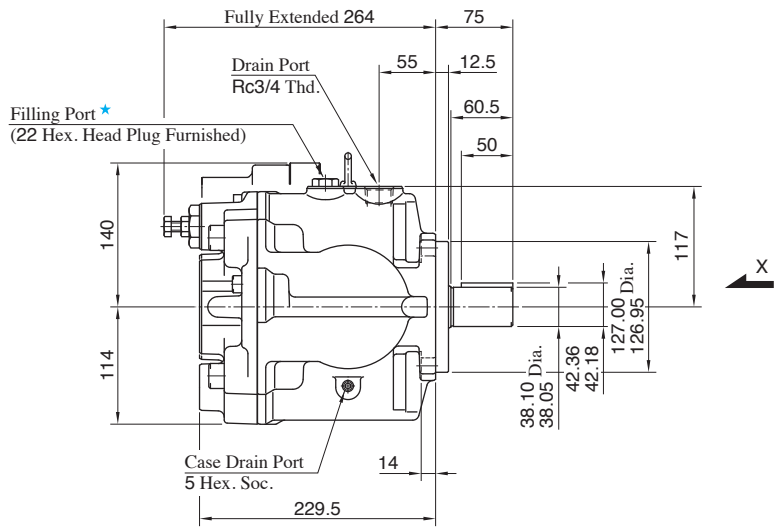
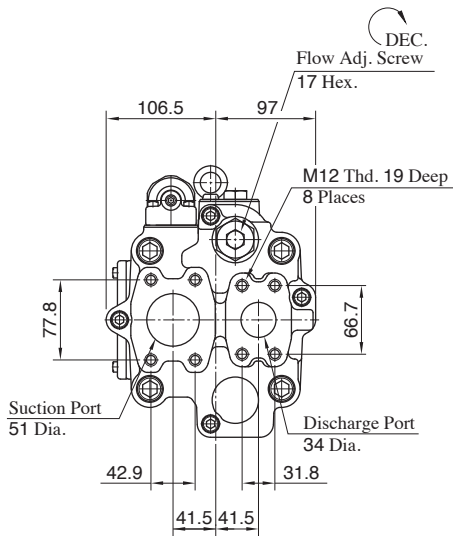

View Arrow X

★ Install the pump so that the "Filling Port" is at the top.

Foot Mtg. : A3H71-LR01KK

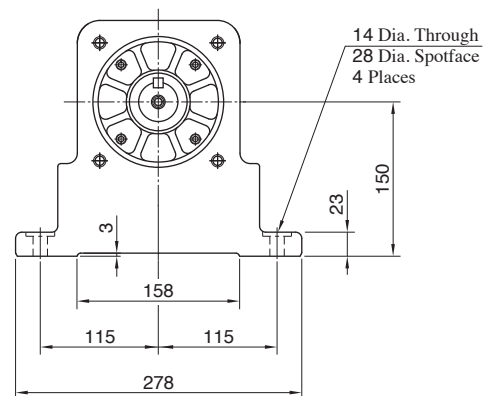
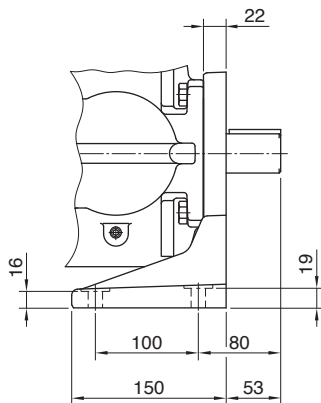

● For other dimensions, refer to "Flange Mtg."

Flange Mtg. : A3H100-FR01KK

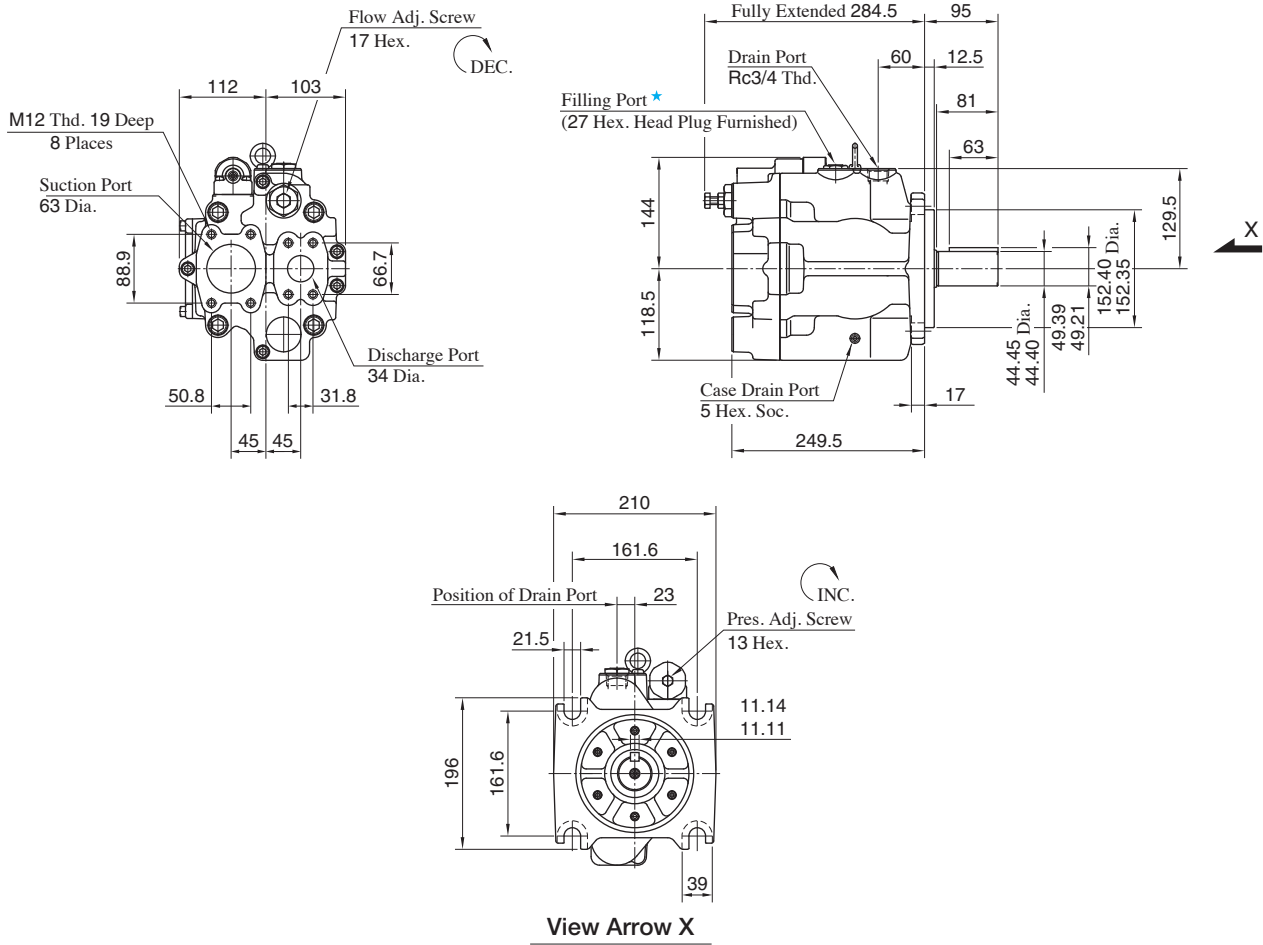

★ Install the pump so that the “Filling Port” is at the top.

Foot Mtg. : A3H100-LR01KK

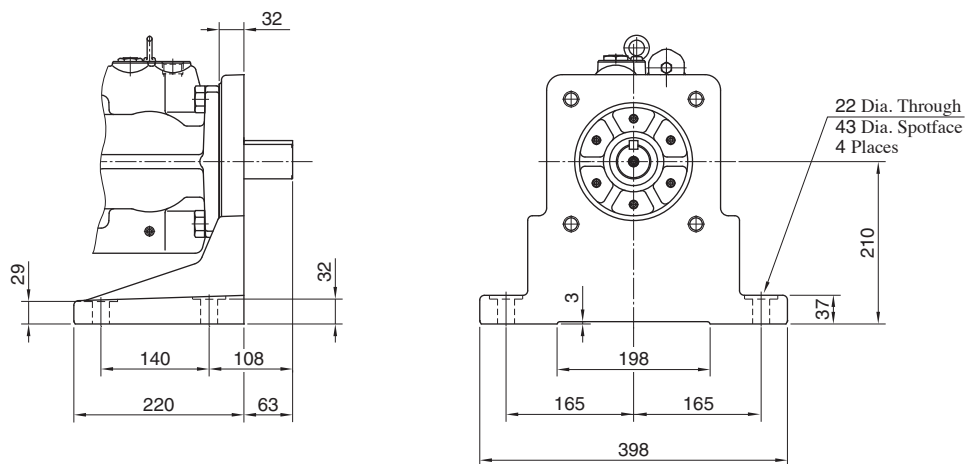

● For other dimensions, refer to “Flange Mtg.”.

Flange Mtg. : A3H145-FR01KK

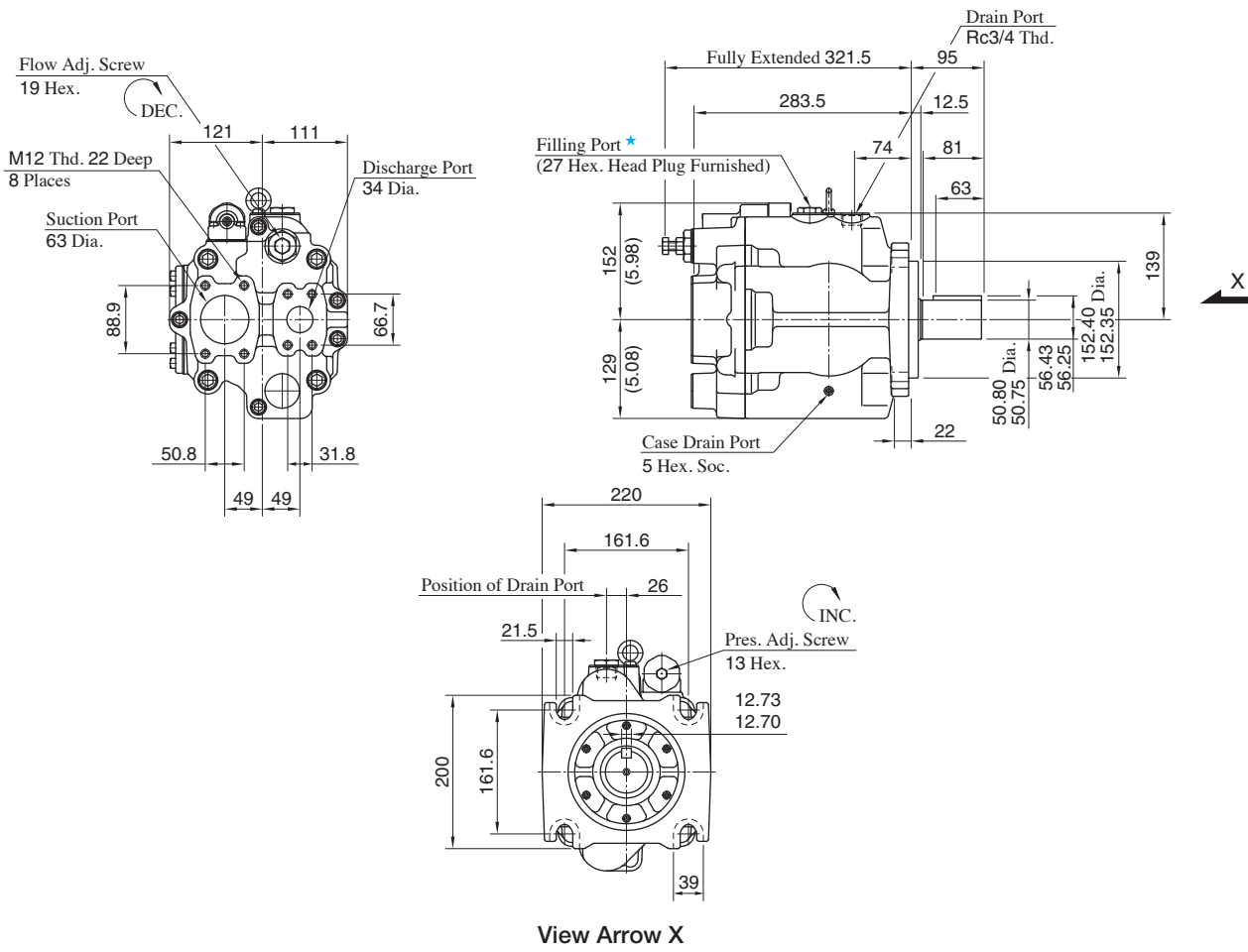

★ Install the pump so that the “Filling Port” is at the top.

Foot Mtg. : A3H145-LR01KK

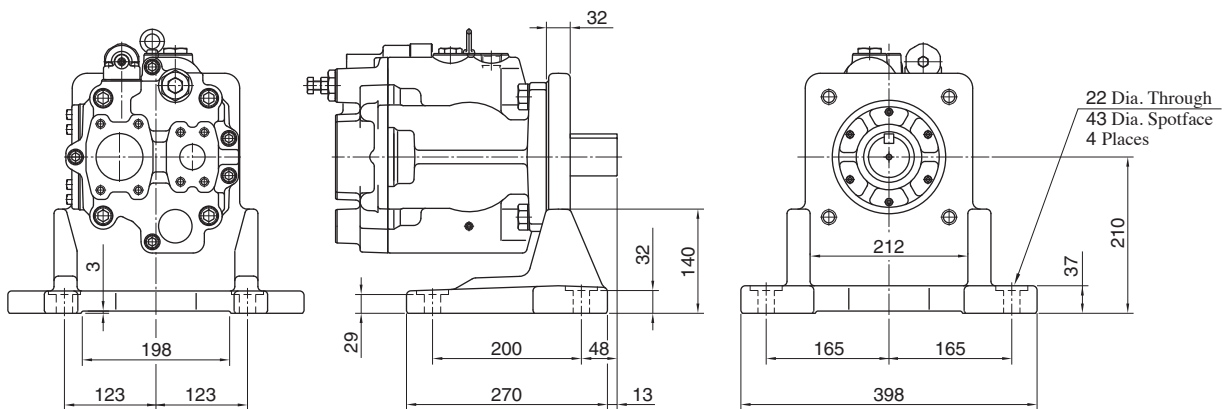

● For other dimensions, refer to “Flange Mtg.”.

Flange Mtg. : A3H180-FR01KK

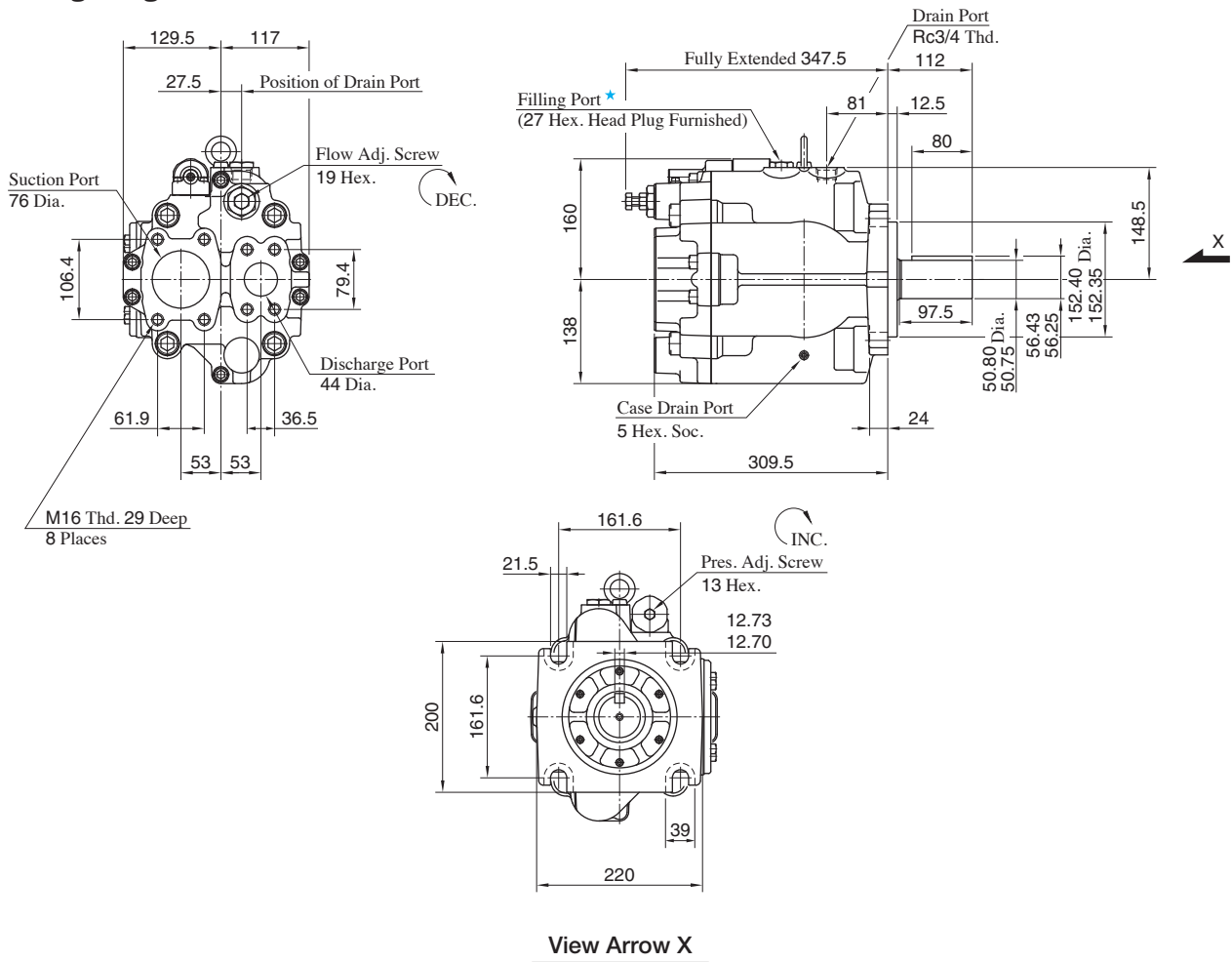

★ Install the pump so that the “Filling Port” is at the top.

Foot Mtg. : A3H180-LR01KK

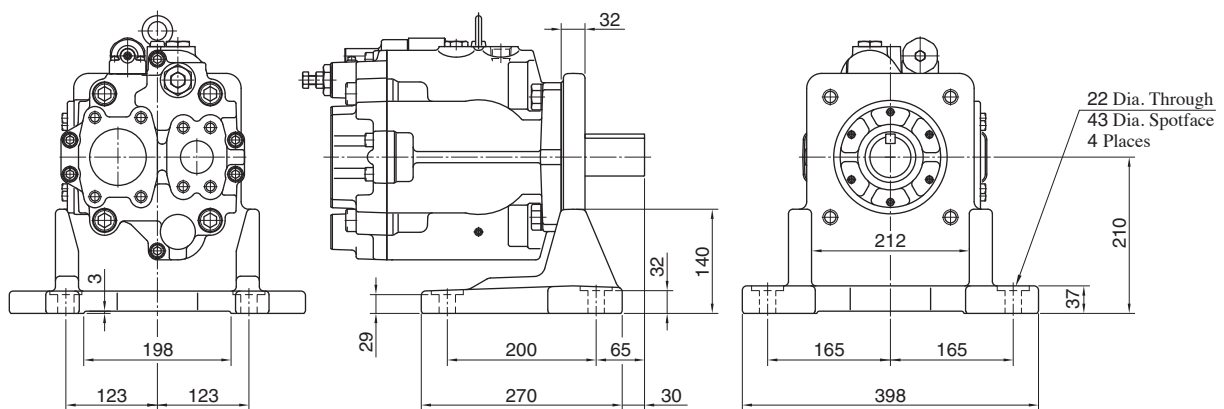

● For other dimensions, refer to “Flange Mtg.”.

Spare Parts List

A3H16/A3H37/A3H56- *R01KK

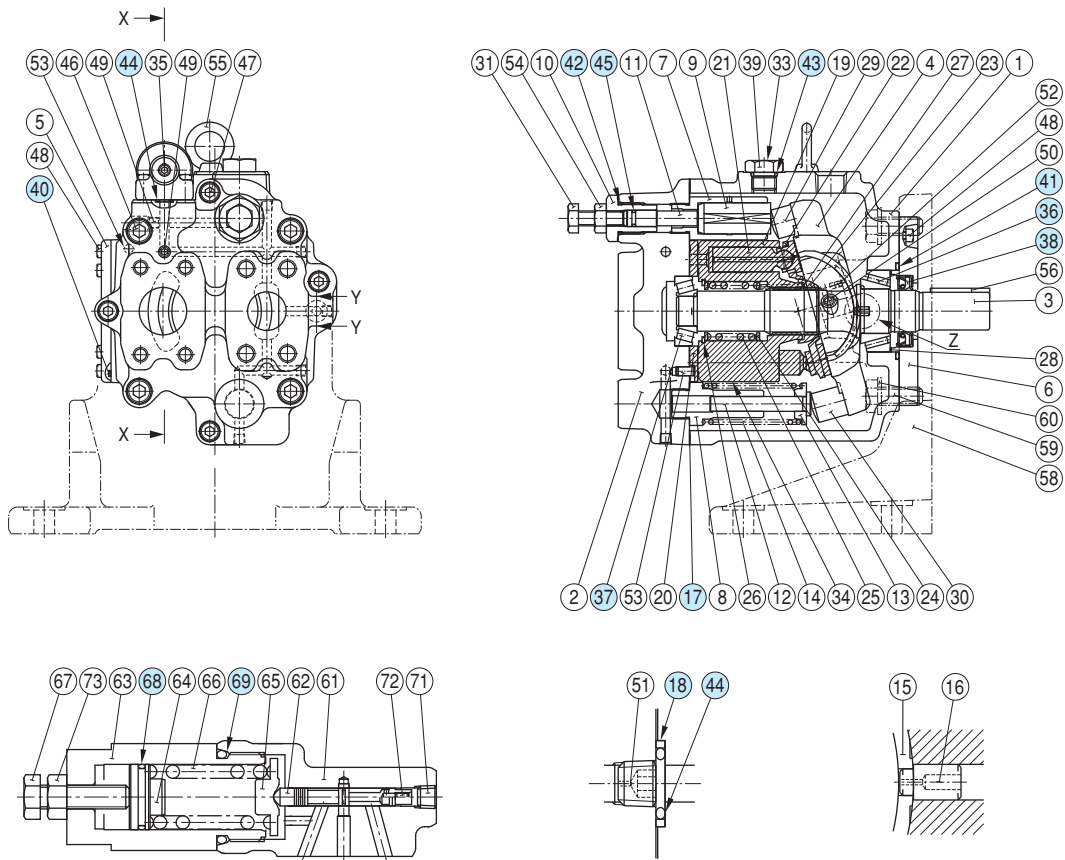

Detail of Section X - X

Detail of Section Y - Y

Detail "Z"

Item	Name of Parts	Part Numbers			Qty.
		A3H16	A3H37	A3H56	
17	Gasket	2270-PK313655-3	2271-PK-313518-3	2272-PK313433-5	1
18	Back Up Ring	1310E-PK412440-0			1
36	Cylindrical Roller Bearing	NUP205E	—	—	1
	Tapered Roller Bearing	—	4T-30204	4T-33008	
37	Needle Roller Bearing	HMK2025V2	—	—	1
	Tapered Roller Bearing	—	4T-33006	4T-32205R	
38	Oil Seal	TCN254511 (FKM)	TCN284811 (FKM)	TCN355511 (FKM)	1
40	O-Ring	S65 (NBR-70)	S85 (NBR-70)	S95 (NBR-70)	1
41	O-Ring	OR NBR-70 G60-N	OR NBR-70 G60-N	S71 (NBR-70)	1
42	O-Ring	OR NBR-90 P14-N	OR NBR-90 P18-N	OR NBR-90 P21-N	1
43	O-Ring	OR NBR-90 P14-N			1
44	O-Ring	OR NBR-90 P9-N			4
45	O-Ring	OR NBR-90 P6-N	OR NBR-90 P8-N	OR NBR-90 P9-N	1
68	O-Ring	AS568-A018 (NBR-70)			1
69	O-Ring	OR NBR-90 P26-N			1

Spare Parts List

A3H71/A3H100/A3H145/A3H180- * R01KK

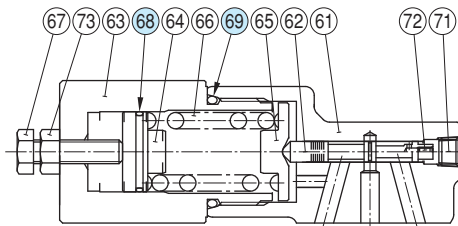
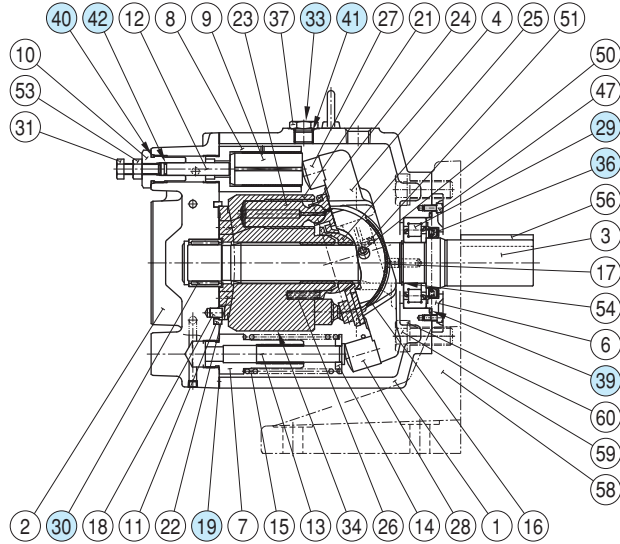
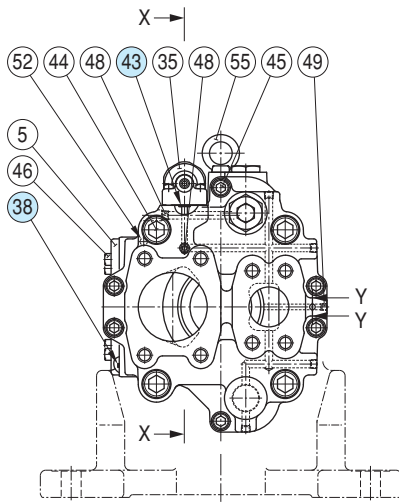

Detail of Section X – X

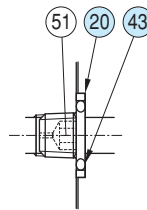

Detail of Section Y – Y

Item	Name of Parts	Part Numbers				Qty.
		A3H71	A3H100	A3H145	A3H180	
19	Gasket	2273-PK212356-0	2274-PK212368-5	2275-PK212382-6	2276-PK212301-6	1
20	Back Up Ring	1310E-PK412440-0				1
29	Tapered Roller Bearing	33009JR	4T-33206	HR33011	—	1
	Cylindrical Roller Bearing	—	—	—	2276-PK412859-1	
30	Tapered Roller Bearing	32205JR	4T-30210	4T-33206	—	1
	Needle Roller Bearing	—	—	—	2276-PK412860-9	
36	Oil Seal	TCN426512 (FKM)	TCN507212 (FKM)	TCN557812 (FKM)	TCN557812 (FKM)	1
38	O-Ring	S100 (NBR-70)	S110 (NBR-70)	S125 (NBR-70)	S130 (NBR-70)	1
39	O-Ring	OR NBR-70 G80-N	OR NBR-70 G95-N	OR NBR-70 G95-N	OR NBR-70 G105-N	1
40	O-Ring	OR NBR-90 P24-N		OR NBR-90 P26-N		1
41	O-Ring	OR NBR-90 P14-N	OR NBR-90 P18-N	OR NBR-90 P18-N		1
42	O-Ring	OR NBR-90 P9-N		OR NBR-90 P10A-N		1
43	O-Ring	OR NBR-90 P9-N				4
68	O-Ring	AS568-A021 (NBR-70)				1
69	O-Ring	OR NBR-90 P32-N				1

A3H Series High Pressure Variable Displacement Piston Pumps, Constant Power (Torque) Control Type

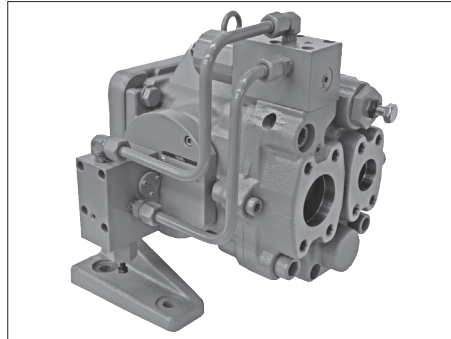

Graphic Symbol

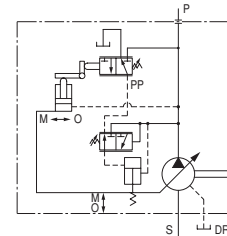

Specifications

Model Numbers	Geometric Displacement cm ³ /rev	Minimum Adj. Flow cm ³ /rev	Max. Operating Pressure MPa	Shaft Speed Range r/min		Approx. Mass kg	
				Max.*	Min.	Flange Mtg.	Foot Mtg.
A3H 37- *R09- * * *K-10	37.1	16.0	35	2700	600	23.0	30.5
A3H 56- *R09- * * *K-10	56.3	35.0		2500	600	29.0	36.5
A3H 71- *R09- * * *K-10	70.7	45.0		2300	600	38.0	45.5
A3H100- *R09- * * *K-10	100.5	63.0		2100	600	48.3	76.3
A3H145- *R09- * * *K-10	145.2	95.0		1800	600	63.0	91.0
A3H180- *R09- * * *K-10	180.7	130.0		1800	600	74.2	102.2

★ The maximum shaft speeds shown in the above table are at suction pressure 0 kPa.

Model Number Designation

A3H37	-F	R	09	-11	A	4	K	-10
Series Number	Mounting	Direction of Rotation	Control Type	Input Power Setting	Frequency of Power Source	Pole Number of Electric Motor	Shaft Extension★ ²	Design Number
A3H37 (37.1 cm ³ /rev)	F: Flange Mtg. L: Foot Mtg.	(Viewed from Shaft End) R: Clockwise★ ¹ (Normal)	09: Constant Power (Torque) Control Type	5.5: 5.5 kW 110: 110 kW Refer to the table on following page for combination.	A: 50 Hz B: 60 Hz	4: 4 Poles 6: 6 Poles	K: Keyed Shaft	10
A3H56 (56.3 cm ³ /rev)								10
A3H71 (70.7 cm ³ /rev)								10
A3H100 (100.5 cm ³ /rev)								10
A3H145 (145.2 cm ³ /rev)								10
A3H180 (180.7 cm ³ /rev)								10

★¹. Available to supply pump with anti-clockwise rotation. Consult Yuken for details.

★². We can also supply spline-type shaft extension. Consult Yuken for details.

● Combination of Pump Series and Input Power Setting (○= Available Combinations)

Model Numbers		Input Power Setting kW																						
		Pole Number of Electric Motor : 4P										Pole Number of Electric Motor : 6P												
		11	15	18.5	22	30	37	45	55	75	90	110	5.5	7.5	11	15	18.5	22	30	37	45	55	75	
A3H 37	50 Hz	○	○	○											○	○	○							
	60 Hz	○	○	○	○											○	○	○						
A3H 56	50 Hz		○	○	○	○										○	○	○						
	60 Hz			○	○	○	○										○	○	○					
A3H 71	50 Hz			○	○	○	○										○	○	○					
	60 Hz				○	○	○	○										○	○	○				
A3H100	50 Hz				○	○	○	○	○									○	○	○				
	60 Hz					○	○	○	○										○	○	○			
A3H145	50 Hz					○	○	○	○	○								○	○	○	○	○	○	○
	60 Hz						○	○	○	○	○								○	○	○	○	○	○
A3H180	50 Hz						○	○	○	○	○								○	○	○	○	○	○
	60 Hz							○	○	○	○	○								○	○	○	○	○

■ Pipe Flange Kits

For pipe flange, refer to form of pressure compensator type on page A-117.

Typical Performance Characteristics of Control Type 09 at Viscosity 32 mm²/s [ISO VG32 Oils, 40°C]

● A3H37

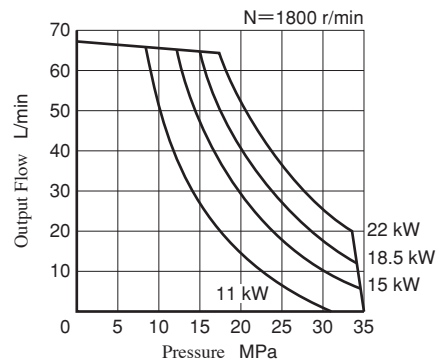
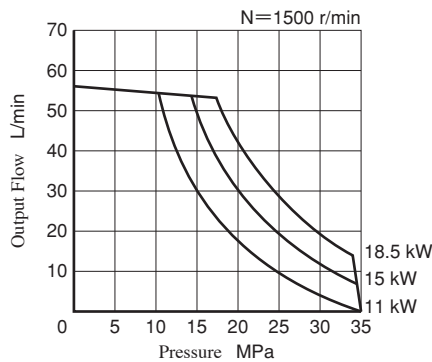

● A3H56

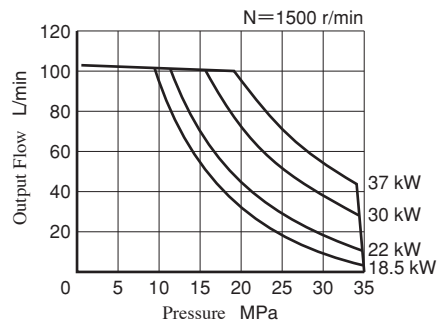
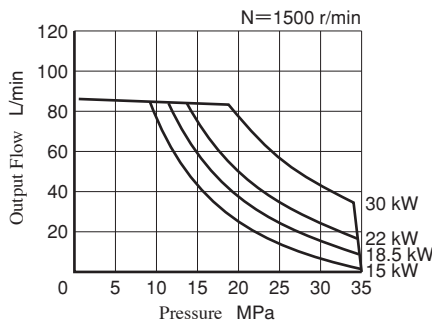

Typical Performance Characteristics of Control Type **09** at Viscosity 32 mm²/s [ISO VG32 Oils, 40°C]

● **A3H71**

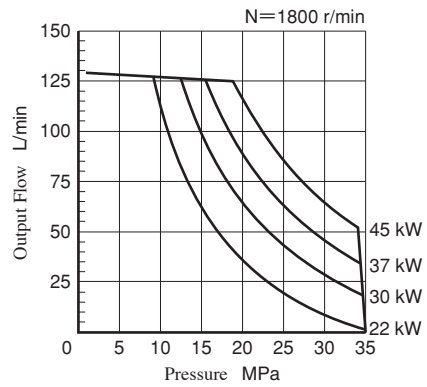
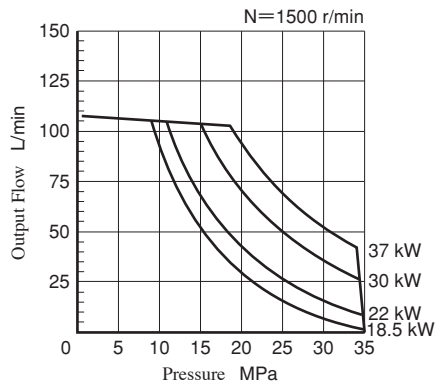

● **A3H100**

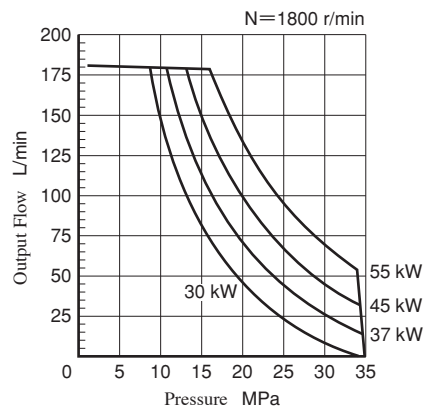
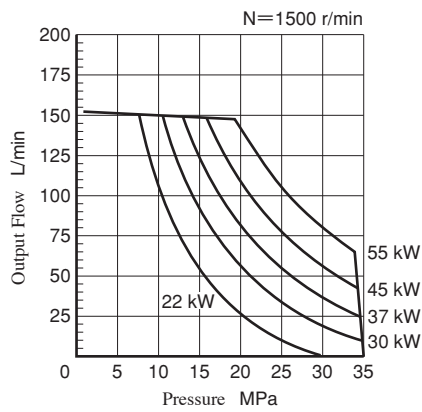

● **A3H145**

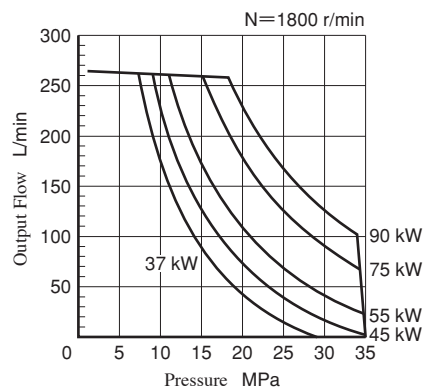
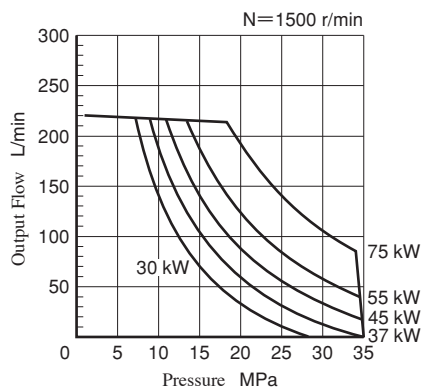

● **A3H180**

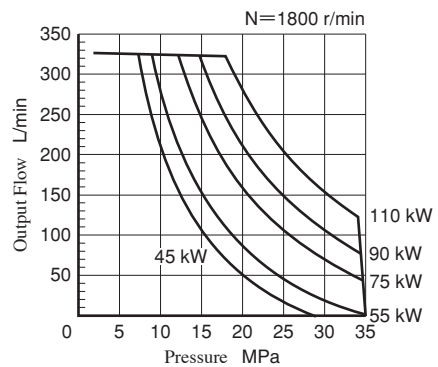
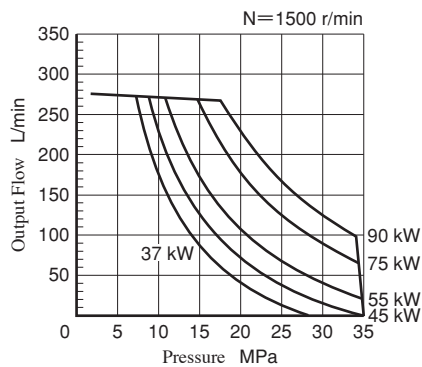

Flange Mtg. : A3H37-FR09-*K**

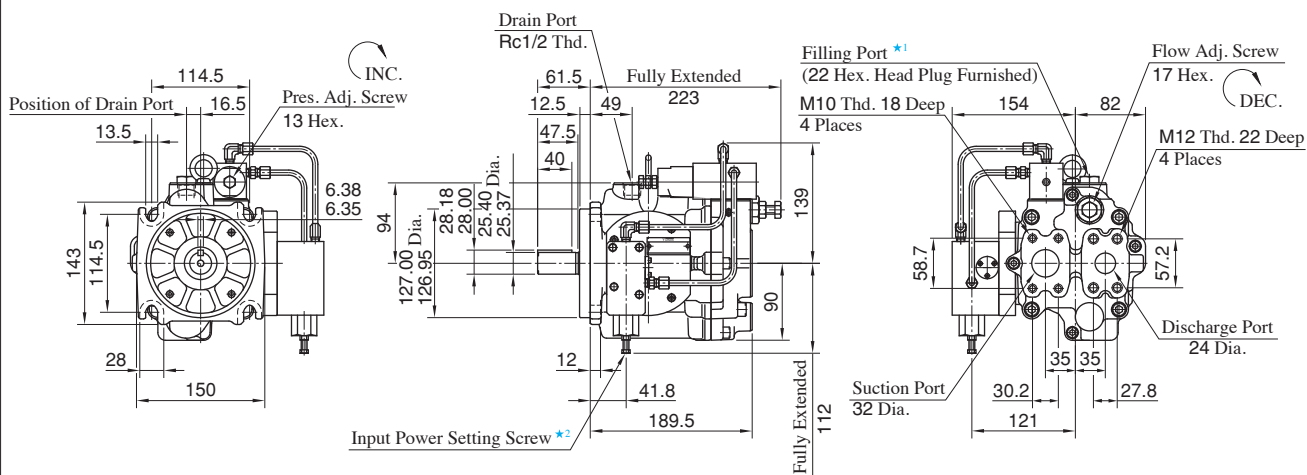

- ★1. Install the pump so that the "Filling Port" is at the top.
- ★2. Do not touch the screw because it is adjusted at the time of shipment.

● **Foot Mounting Type**

Mounting bracket is common to that of pressure compensator model.
Refer to page A-127 for the dimensions of mounting bracket.

Flange Mtg. : A3H56-FR09-*K**

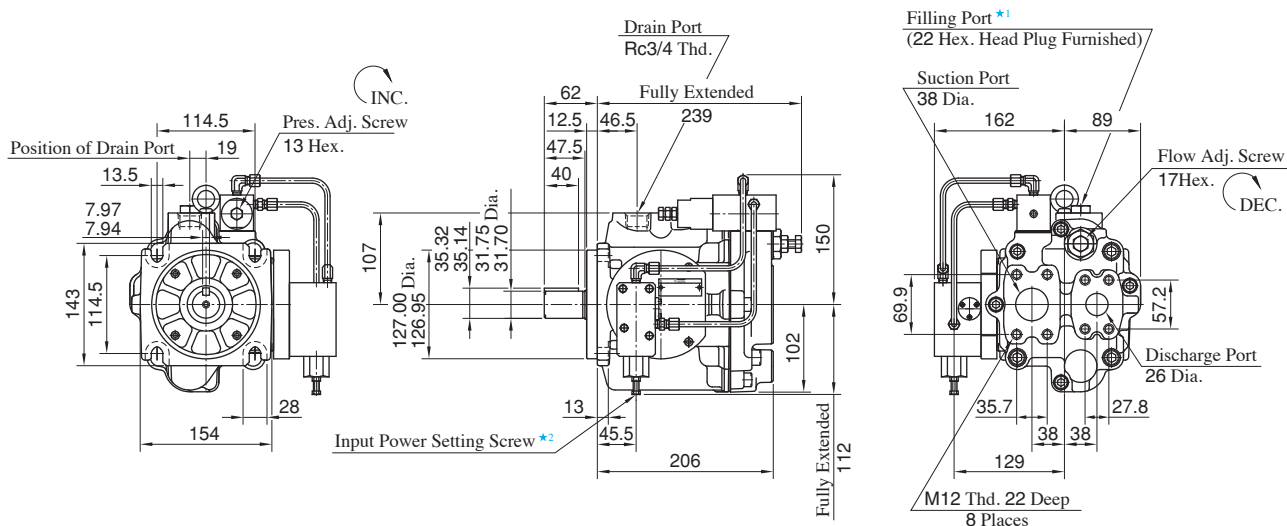

- ★1. Install the pump so that the "Filling Port" is at the top.
- ★2. Do not touch the screw because it is adjusted at the time of shipment.

● **Foot Mounting Type**

Mounting bracket is common to that of pressure compensator model.
Refer to page A-128 for the dimensions of mounting bracket.

Flange Mtg. : A3H71-FR09-***K

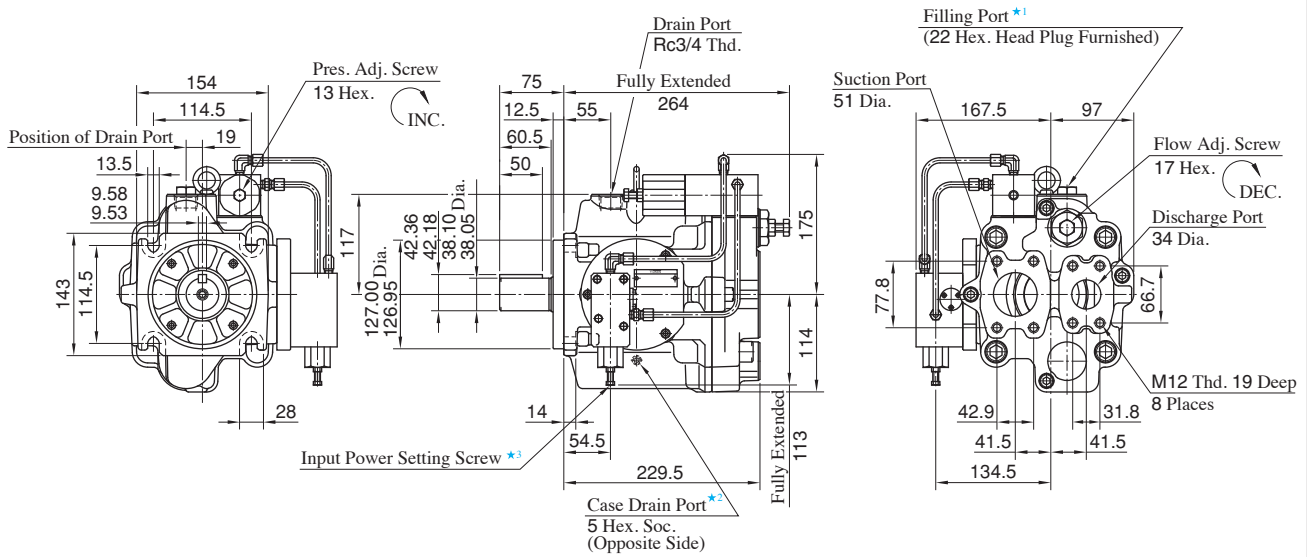

- ★1. Install the pump so that the "Filling Port" is at the top.
- ★2. Please use case drain port in case of discharge the hydraulic oil in the pump casing.
- ★3. Do not touch the screw because it is adjusted at the time of shipment.

● Foot Mounting Type

Mounting bracket is common to that of pressure compensator model.
Refer to page A-129 for the dimensions of mounting bracket.

Flange Mtg. : A3H100-FR09-***K

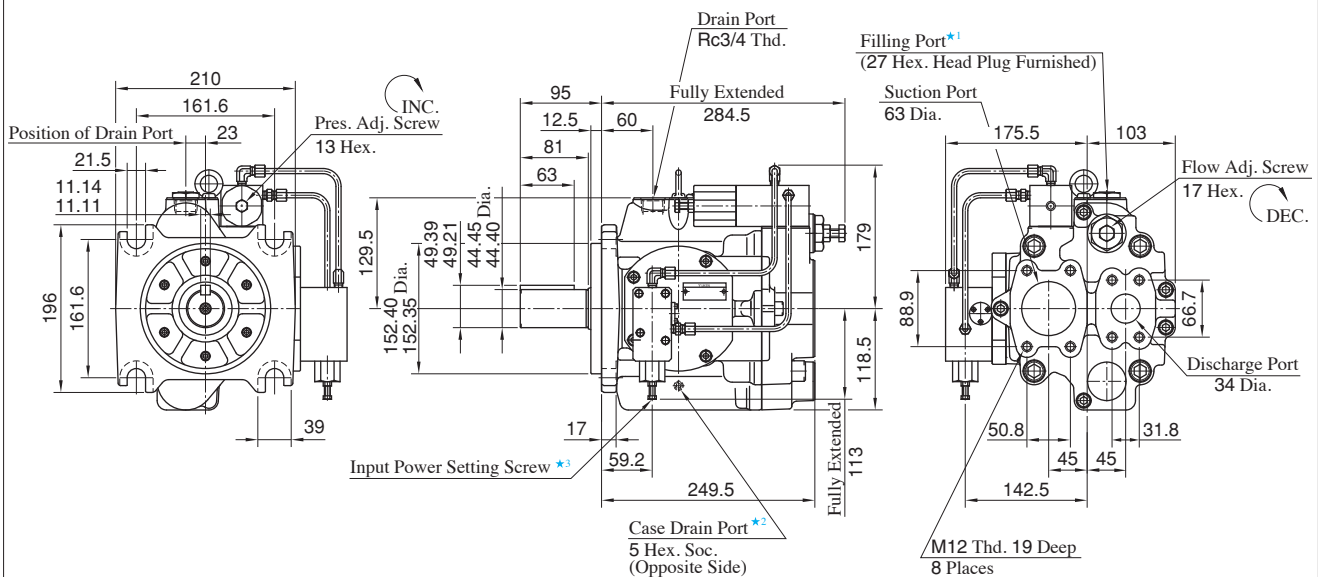

- ★1. Install the pump so that the "Filling Port" is at the top.
- ★2. Please use case drain port in case of discharge the hydraulic oil in the pump casing.
- ★3. Do not touch the screw because it is adjusted at the time of shipment.

● Foot Mounting Type

Mounting bracket is common to that of pressure compensator model.
Refer to page A-130 for the dimensions of mounting bracket.

Flange Mtg. : A3H145-FR09-*K**

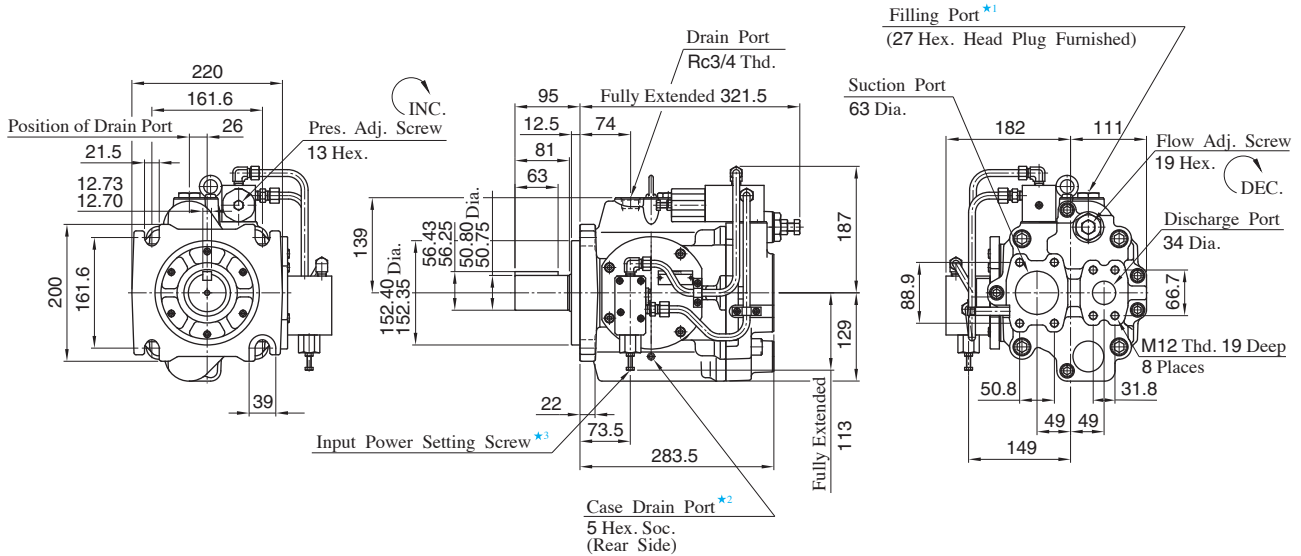

- ★1. Install the pump so that the "Filling Port" is at the top.
- ★2. Please use case drain port in case of discharge the hydraulic oil in the pump casing.
- ★3. Do not touch the screw because it is adjusted at the time of shipment.

● **Foot Mounting Type**

Mounting bracket is common to that of pressure compensator model.
Refer to page A-131 for the dimensions of mounting bracket.

Flange Mtg. : A3H180-FR09-*K**

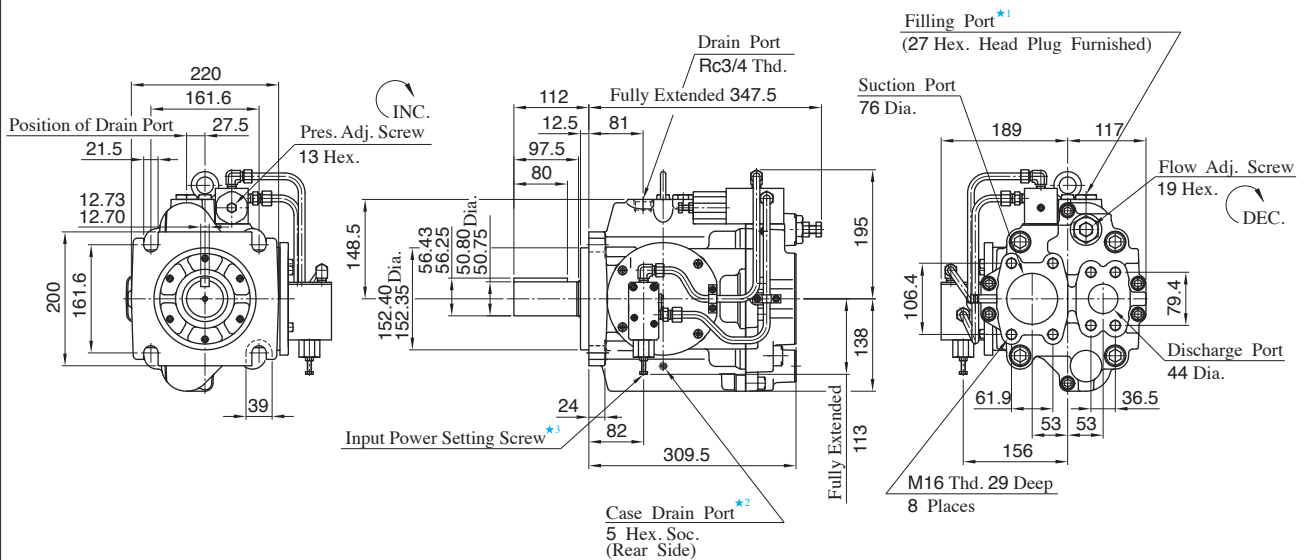

- ★1. Install the pump so that the "Filling Port" is at the top.
- ★2. Please use case drain port in case of discharge the hydraulic oil in the pump casing.
- ★3. Do not touch the screw because it is adjusted at the time of shipment.

● **Foot Mounting Type**

Mounting bracket is common to that of pressure compensator model.
Refer to page A-132 for the dimensions of mounting bracket.

A3H Series High Pressure Variable Displacement Piston Pumps, Load Sensing Type

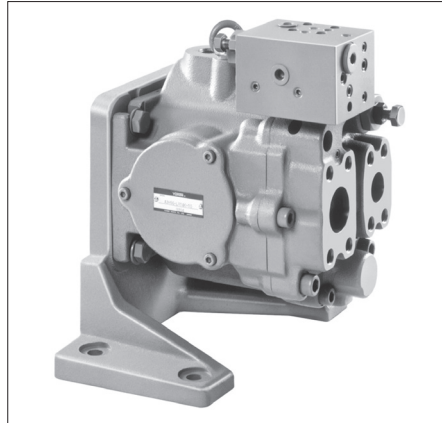

Graphic Symbol

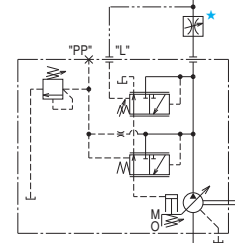

★ A flow control valve is not included with the pump. Install the valve separately.

Specifications

Model Numbers	Geometric Displacement cm ³ /rev	Operating Pressure★ ¹ MPa		Load Sensing Pres. Difference ΔP MPa	Shaft Speed Range r/min		Approx. Mass kg	
		Rated	Intermittent		Max.★ ³	Min.	Flange Mtg.	Foot Mtg.
A3H 16- *R14K-10	16.3	28	35	1.5 (At the time) (of shipment)★ ²	3600	600	17.5	26.4
A3H 37- *R14K-10	37.1				2700	600	22.5	30.0
A3H 56- *R14K-10	56.3				2500	600	28.7	36.2
A3H 71- *R14K-10	70.7				2300	600	38.0	45.5
A3H100- *R14K-10	100.5				2100	600	47.9	75.9
A3H145- *R14K-10	145.2				1800	600	63.0	91.0
A3H180- *R14K-10	180.7				1800	600	73.4	101.4

- ★1. The operating pressure means pump discharge pressure.
- ★2. Load pressure difference ΔP is adjustable in range of 1.0 - 3.0 MPa.
- ★3. The maximum shaft speeds shown in the above table are at suction pressure 0 kPa.

Model Number Designation

A3H37	-F	R	14	K	-10
Series Number	Mounting	Direction of Rotation	Control Type	Shaft Extension★ ²	Design Number
A3H16 (16.3 cm ³ /rev)	F: Flange Mtg. L: Foot Mtg.	(Viewed from) Shaft End R: Clockwise★ ¹ (Normal)	14: Load Sensing Type	K: Keyed Shaft	10
A3H37 (37.1 cm ³ /rev)					10
A3H56 (56.3 cm ³ /rev)					10
A3H71 (70.7 cm ³ /rev)					10
A3H100 (100.5 cm ³ /rev)					10
A3H145 (145.2 cm ³ /rev)					10
A3H180 (180.7 cm ³ /rev)					10

- ★1. Available to supply pump with anti-clockwise rotation. Consult Yuken for details.
- ★2. We can also supply spline-type shaft extension. Consult Yuken for details.

■ Pipe Flange Kits

Pipe flange kits are available. When ordering, specify the kit number from the table below.

Pump Model Numbers	Name of Port	Pipe Flange Kits Number		
		Threaded Connection*	Socket Welding	Butt Welding
A3H 16- *R14K	Suction	F5-08-A-10	F5-08-B-10	F5-08-C-10
	Discharge	F6-06-A-M-10	F6-06-B-M-10	—
A3H 37- *R14K	Suction	F5-10-A-10	F5-10-B-10	F5-10-C-10
	Discharge	F6-08-A-M-10	F6-08-B-M-10	—
A3H 56- *R14K	Suction	F5-12-A-10	F5-12-B-10	F5-12-C-10
	Discharge	F6-08-A-M-10	F6-08-B-M-10	—
A3H 71- *R14K	Suction	F5-16-A-10	F5-16-B-10	F5-16-C-10
	Discharge	F6-10-A-M-10	F6-10-B-M-10	—
A3H100- *R14K A3H145- *R14K	Suction	F5-20-A-10	F5-20-B-10	F5-20-C-10
	Discharge	F6-10-A-M-10	F6-10-B-M-10	—
A3H180- *R14K	Suction	F5-24-A-10	F5-24-B-10	—
	Discharge	F6-12-A-M-10	F6-12-B-M-10	—

★ These flanges are with tapered threaded port, maximum pressure is restricted at 31 MPa.

Typical Performance Characteristics of Control Type **A3H71** at Viscosity 32 mm²/s [ISO VG32 Oils, 40°C]

■ Pressure vs. Output Flow

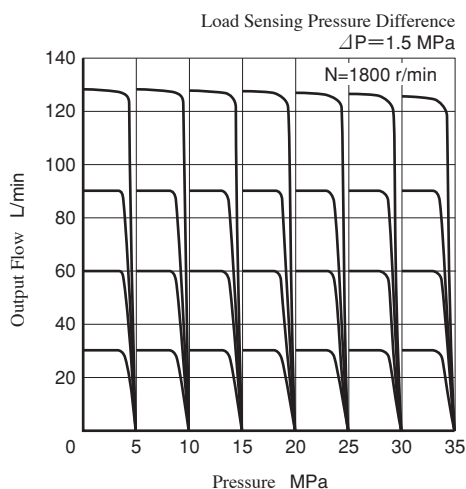

■ Full Cut-off Input Power

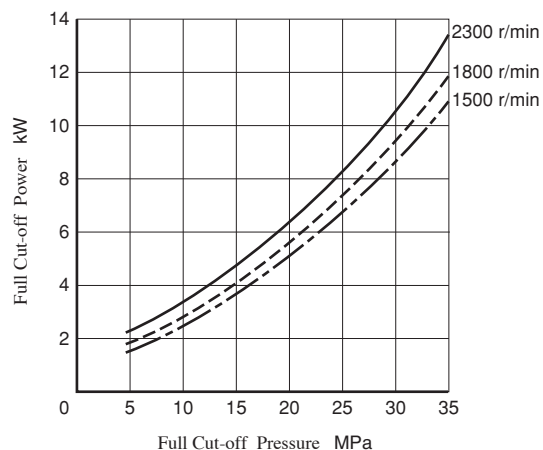

■ Drain

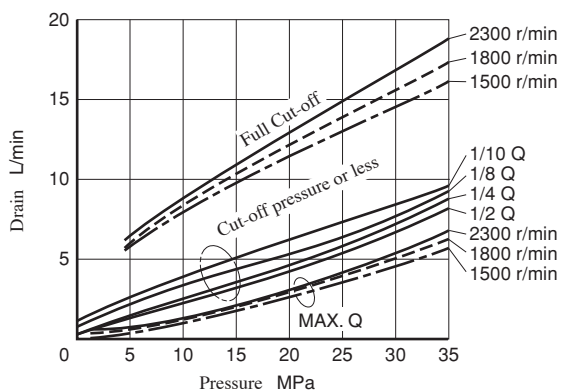

★ Consult Yuken for performance characteristics of other series than A3H71.

Flange Mtg. : A3H16-FR14K

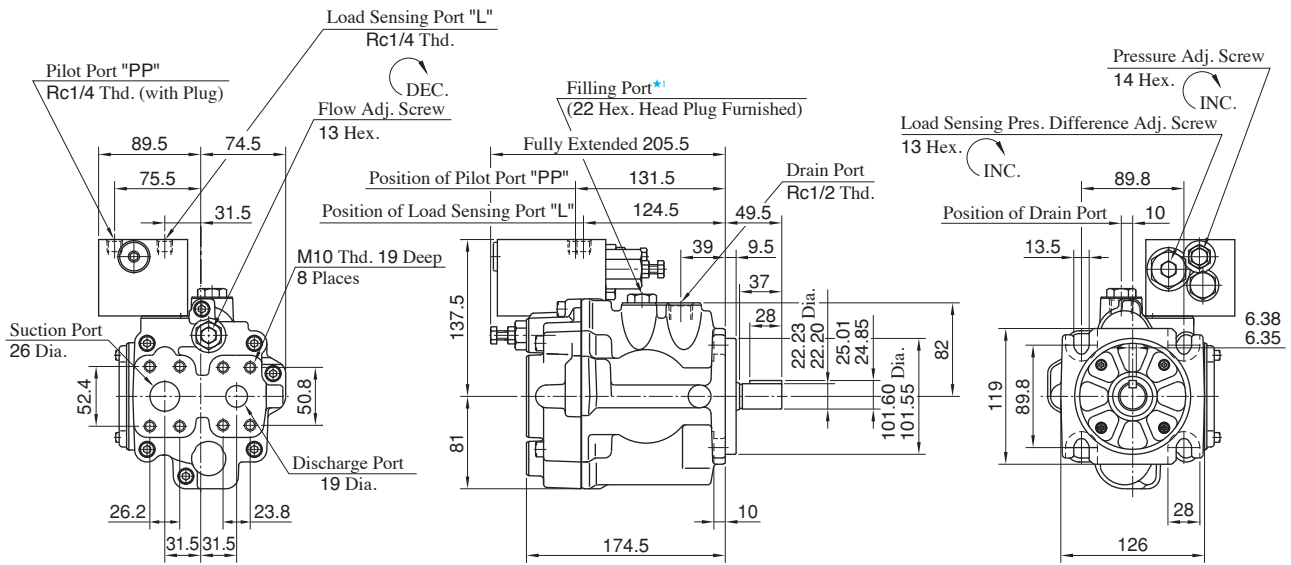

★1. Install the pump so that the "Filling Port" is at the top.

● Foot Mounting Type

Mounting bracket is common to that of pressure compensator model.
Refer to page A-126 for the dimensions of mounting bracket.

Flange Mtg. : A3H37-FR14K

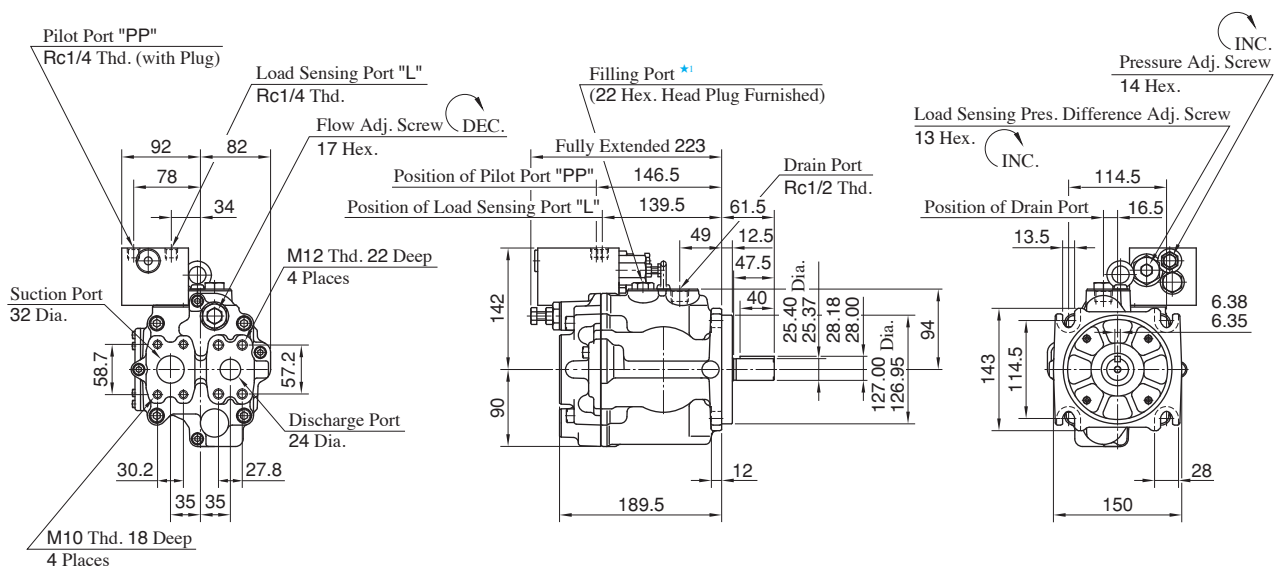

★1. Install the pump so that the "Filling Port" is at the top.

● Foot Mounting Type

Mounting bracket is common to that of pressure compensator model.
Refer to page A-127 for the dimensions of mounting bracket.

Flange Mtg. : A3H56-FR14K

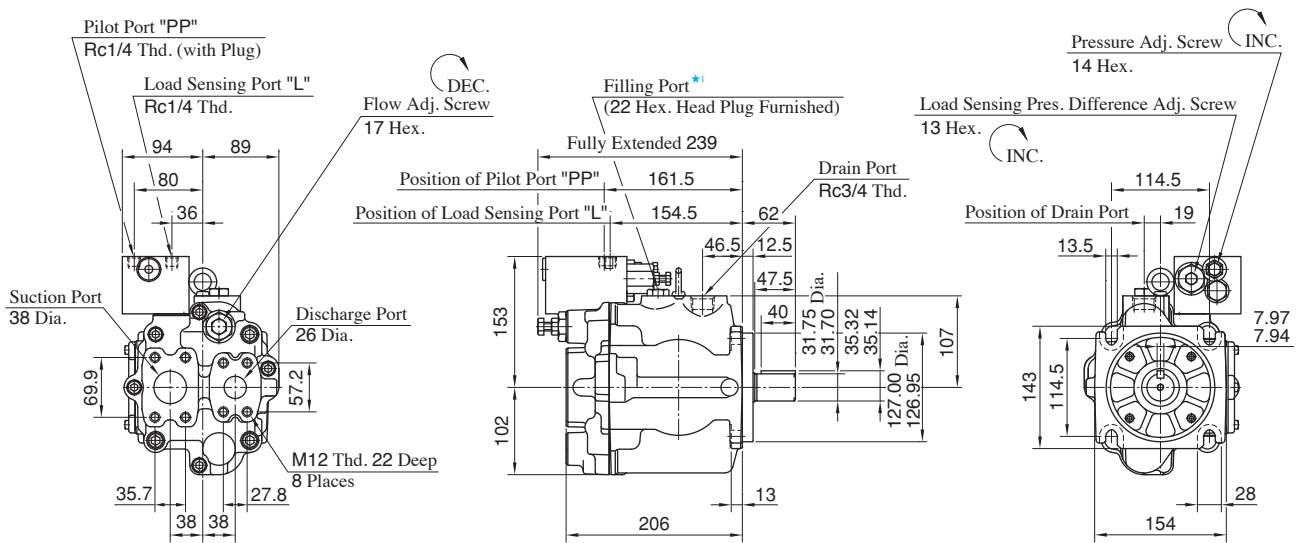

★1. Install the pump so that the "Filling Port" is at the top.

● **Foot Mounting Type**

Mounting bracket is common to that of pressure compensator model.
Refer to page A-128 for the dimensions of mounting bracket.

Flange Mtg. : A3H71-FR14K

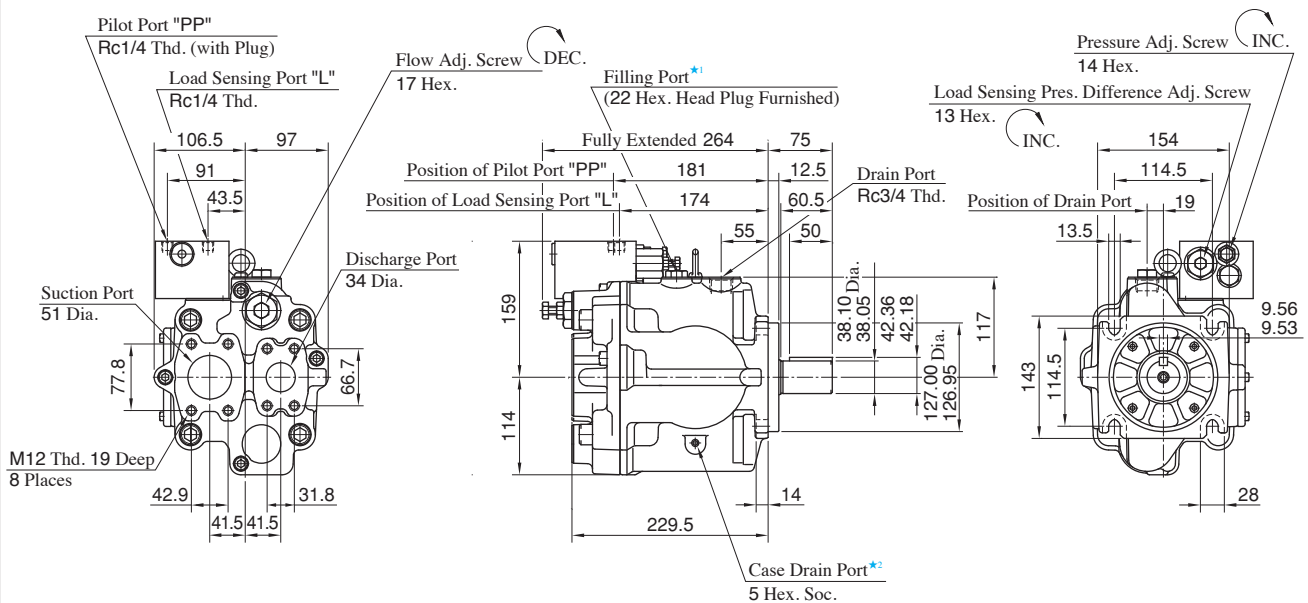

★1. Install the pump so that the "Filling Port" is at the top.

★2. Please use case drain port in case of discharge the hydraulic oil in the pump casing.

● **Foot Mounting Type**

Mounting bracket is common to that of pressure compensator model.
Refer to page A-129 for the dimensions of mounting bracket.

Flange Mtg. : A3H100-FR14K

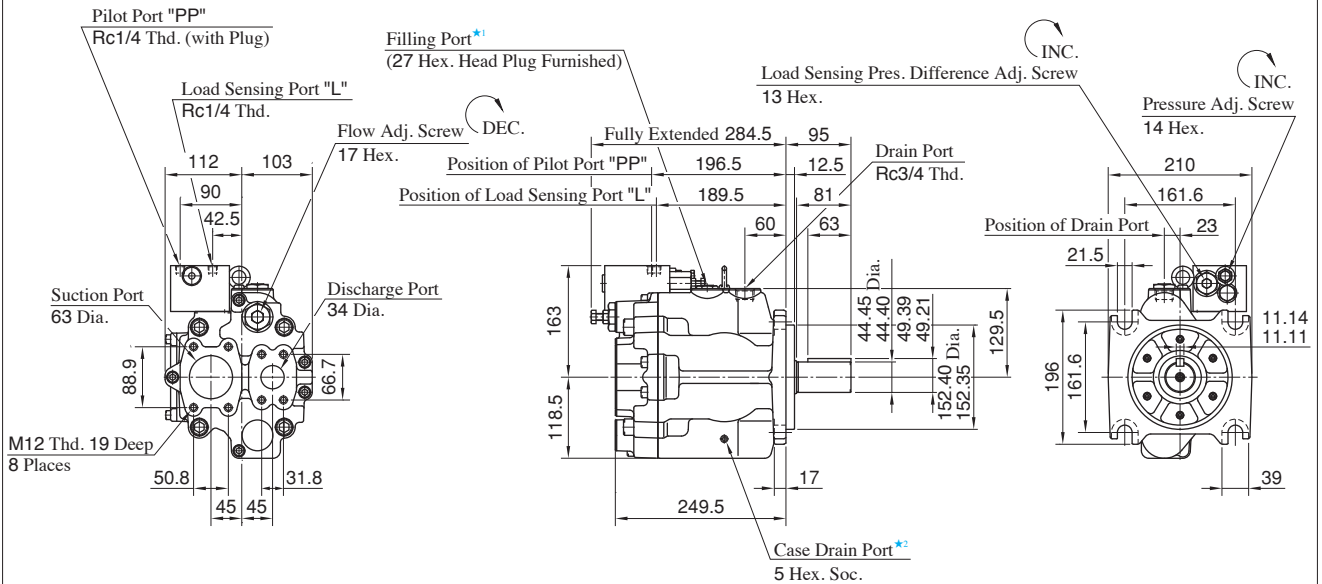

- ★1. Install the pump so that the "Filling Port" is at the top.
- ★2. Please use case drain port in case of discharge the hydraulic oil in the pump casing.

● Foot Mounting Type

Mounting bracket is common to that of pressure compensator model.
Refer to page A-130 for the dimensions of mounting bracket.

Flange Mtg. : A3H145-FR14K

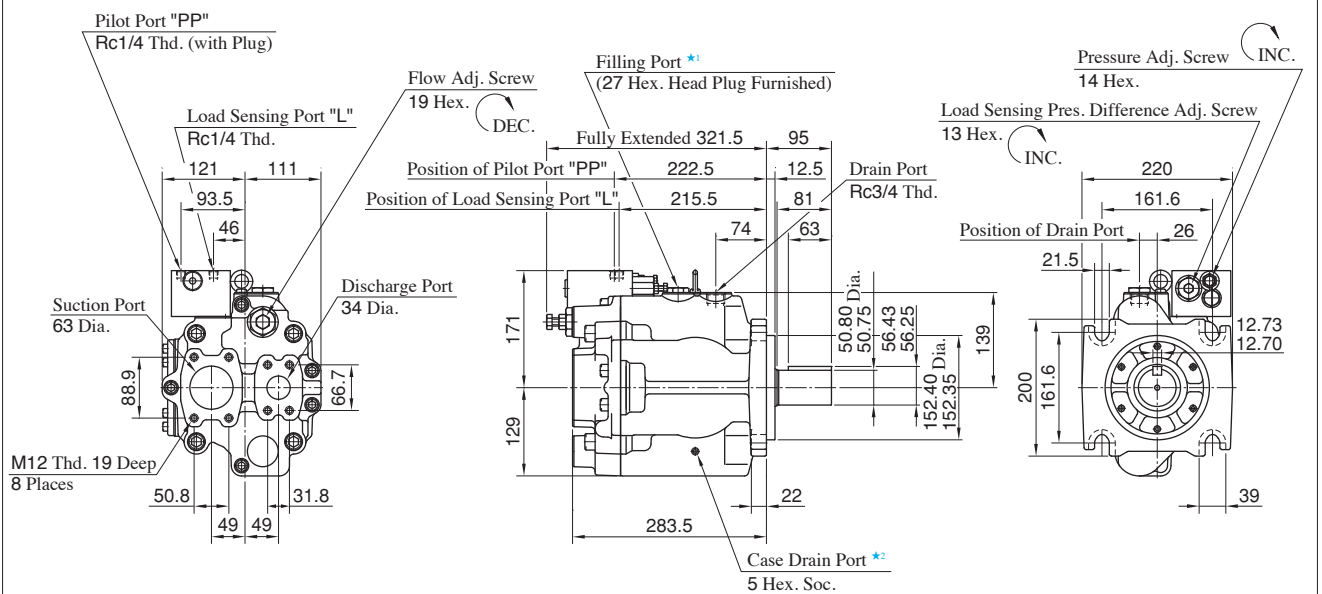

- ★1. Install the pump so that the "Filling Port" is at the top.
- ★2. Please use case drain port in case of discharge the hydraulic oil in the pump casing.

● Foot Mounting Type

Mounting bracket is common to that of pressure compensator model.
Refer to page A-131 for the dimensions of mounting bracket.

Flange Mtg. : A3H180-FR14K

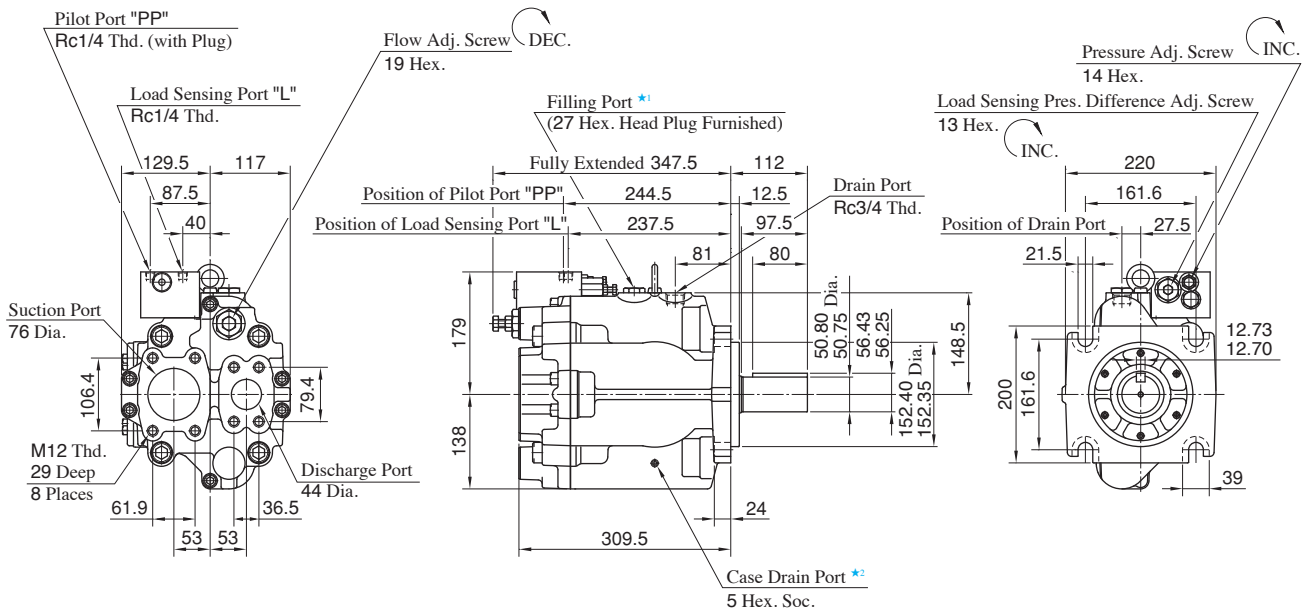

- ★1. Install the pump so that the "Filling Port" is at the top.
- ★2. Please use case drain port in case of discharge the hydraulic oil in the pump casing.

● **Foot Mounting Type**

Mounting bracket is common to that of pressure compensator model.
Refer to page A-132 for the dimensions of mounting bracket.

A3H Series High Pressure Variable Displacement Piston Pumps, Simple Two-Pressure Two-Flow Control Type

Graphic Symbol

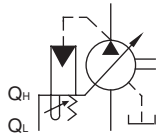

Performance Characteristics

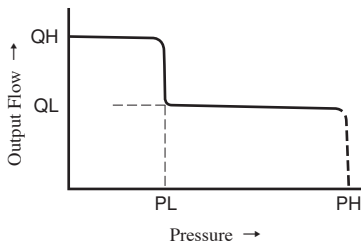

Specifications

Model Numbers	Geometric Displacement cm ³ /rev	Delivery Volume Adj. Range cm ³ /rev		Operating Pressure MPa		Shaft Speed Range r/min
		Large Displacement (QH)	Small Displacement (QL)	Rated	Intermittent	
A3H16- *R55-KK-10	16.3	8 - 16.3	★ - 8	25	25	600 - 3600
A3H37- *R55-KK-10	37.1	16 - 37.1	★ - 19			600 - 2700
A3H56- *R55-KK-10	56.3	35 - 56.3	★ - 30			600 - 2500
A3H71- *R55-KK-10	70.7	45 - 70.7	★ - 35			600 - 2300
A3H100- *R55-KK-10	100.5	63 - 100.5	★ - 48			600 - 2100
A3H145- *R55-KK-10	145.2	95 - 145.2	★ - 60			600 - 1800
A3H180- *R55-KK-10	180.7	130 - 180.7	★ - 90			600 - 1800

Note) ★ Pressure, PH, is the minimum required flow of the external relief valve.

Instruction

Please install the external relief valve since there is no full cut-off performance on this pump.

Model Number Designation

A3H37	-F	R	55	K	K	-10
Series Number	Mounting	Direction of Rotation	Control Type	Pres. Adj. Range	Shaft Extension	Design Number
A3H16 (16.3 cm ³ /rev)	F: Flange Mtg. L: Foot Mtg.	(Viewed from) Shaft End) R: Clockwise (Normal)	55: Simple Two- Pressure Two- Flow Control Type	K: 5 - 25	K: Keyed Shaft	10
A3H37 (37.1 cm ³ /rev)						10
A3H56 (56.3 cm ³ /rev)						10
A3H71 (70.7 cm ³ /rev)						10
A3H100 (100.5 cm ³ /rev)						10
A3H145 (145.2 cm ³ /rev)						10
A3H180 (180.7 cm ³ /rev)						10

Consult Yuken when detailed material such as dimensions figures is required.

A3HG Series High Pressure Variable Displacement Piston Pumps

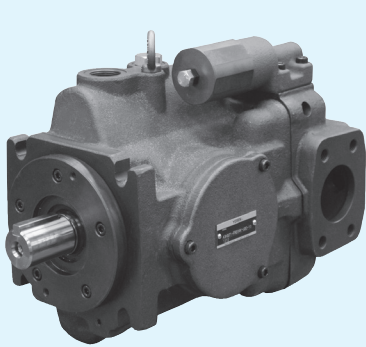

A3HG71

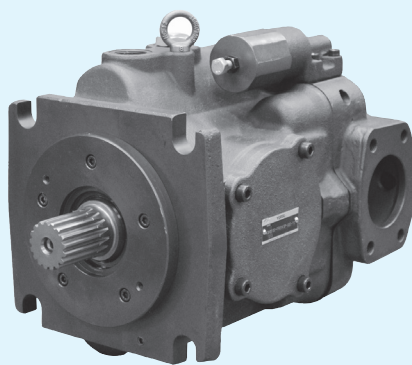

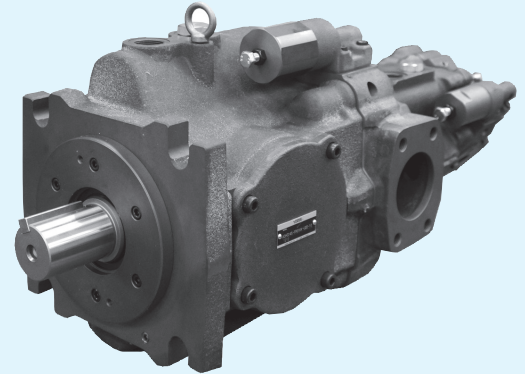

A3HG100



A3HG Through Drive

“A3HG” Series High Pressure Variable Displacement Piston Pumps

Pump Type	Graphic Symbol	Geometric Displacement cm ³ /rev								Maximum Operating Pressure MPa	Page		
		1	2	5	10	20	50	100	200			300	
 Series High Pressure Variable Displacement Piston Pumps	 Single Pump				A3HG16						35	A-151	
					A3HG37								
						A3HG56							
						A3HG71							
						A3HG100							
						A3HG145							
						A3HG180							

★ Four control types are available such as pressure compensator type. Refer to page A-152.

Hydraulic Fluids

Hydraulic Fluids

Use clean petroleum base oils equivalent to ISO VG-32 or 46. The recommended viscosity range is from 20 to 400 mm²/s and temperature range is from 0 to 60 C°, both of which have to be satisfied for the use of the above hydraulic oils.

Control of Contamination

Due caution must be paid to maintaining control over contamination of the operating oil which can otherwise lead to breakdowns and shorten the life of the unit. Please maintain the degree of contamination within NAS Grade 9.

The suction port must be equipped with at least a 100 μm (150 mesh) reservoir type filter and the return line must have a line filter of under 10 μm.

Instructions

Mounting

When installing the pump the filling port should be positioned upwards.

Alignment of Shaft

Employ a flexible coupling whenever possible, and avoid any stress from bending or thrust. Maximum permissible misalignment is less than 0.1 mm TIR and maximum permissible misangular is less than 0.2.

Suction Pressure

Permissible suction pressure at suction port of the pump is between -16.7 and +50 kPa. In case of the speed is over 1800 r/min, adjust the pressure 0 to +50 kPa.

For piping to the suction port, use the pipes of the same diameter as that of the specified pipe flange to be used. Make sure that the height of the pump suction port is within one meter from the oil level in the reservoir.

Hints on Piping

When using steel pipes for the suction or discharge ports, excessive load from the piping to the pump generates excessive noise.

Whenever there is fear of excessive load, please use rubber hoses.

Suction Piping

In case the pump is installed above the oil level, the suction piping and suction line filter should be located lower than the pump position to prevent air in the suction line.

Pilot Piping

Install pilot piping according to the chart.

[Recommended Pilot Piping Size]

Port /Flange Code	Fitting Size	Inside Dia. of Pipe
E1	M14×1.5	6 mm or more
U1	1/2-20UNF	
U2	G 1/4	
J1	R 1/4	

Drain Piping

Install drain piping according to the chart and ensure that pressure within the pump housing should be maintained at a normal pressure of less than 0.1 MPa and surge pressure of less than 0.5 MPa.

Length of piping should be less than 1 m, and the pipe end should be submerged in oil.

[Recommended Drain Piping Size]

Model	Port /Flange Code	Fitting		Inside Dia. of Pipe
		Size	Inside Dia.	
A3HG16 A3HG37	E1	M22×1.5	12 mm or more	12 mm or more
	U1	7/8-14UNF		
	U2	G 1/2		
A3HG56 A3HG180	J1	R 1/2	16 mm or more	19 mm or more
	E1	M27×2		
	U1	1 1/16-12UNF		
	U2	G 3/4		
	J1	R 3/4		

Safety Valve

When delivery line is blocked suddenly, surge pressure is occurred so a safety valve should be set in the circuit to eliminate any damage on equipment and piping.

Bleeding Air

It may be necessary to bleed air from pump case and outlet line to remove causes of vibration.

Starting

Before first starting, fill pump case with clean operating oil via the fill port.

In order to avoid air blockage when first starting, adjust the control valves so that the discharged oil from the pump is returned direct to the tank or the actuator moves in a free load.

[Volume of Pre-fill Oil Required]

Model	Volume cm ³	Model	Volume cm ³
A3HG16	400	A3HG100	1600
A3HG37	850	A3HG145	2350
A3HG56	1050	A3HG180	3300
A3HG71	1480	—	—

■ **Setting Discharge Pressure and Delivery**

At the time of shipment, the unit has been preset to maximum delivery and minimum discharge pressure. Adjust the preset delivery and pressure to meet your system requirements.

● **Adjustment of Discharge Pressure**

Turning the adjustment screw clockwise, increases pressure. For the volume adjusted by each full turn of the adjustment screw, see the table below. After adjustment, make sure to tighten the lock nut.

[Volume adjusted by each full turn of the pressure adjustment screw]

Model Numbers	Adjustment Volume MPa
A3HG16/A3HG37/A3HG56-01	5.5
A3HG71/A3HG100/A3HG145-01	6.3
A3HG180-01	5.7

● **Adjustment of Delivery**

Turning the flow adjustment screw clockwise, decreases delivery. For the volume adjusted by each full turn of the adjustment screw, see the table below. After adjustment, make sure to tighten the lock nut.

[The minimum adjustment flow and adjustable volume of each full turn of the delivery adjustment screw]

Model Numbers	Adjustable volume with each full turn of the adjustment screw cm ³ /rev	Minimum Adjustment Flow cm ³ /rev
A3HG16	1.4	8
A3HG37	3.3	16
A3HG56	4.2	35
A3HG71	4.9	45
A3HG100	6.2	63
A3HG145	9.4	95
A3HG180	10.3	130

■ **Flow Adjustment Screw Protrusion Length “L” vs. Geometric Displacement (Reference)**

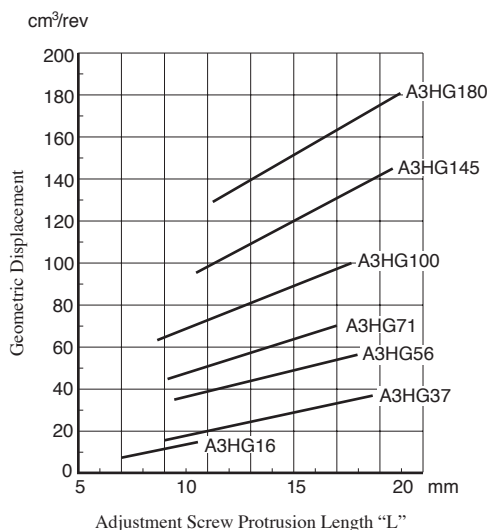
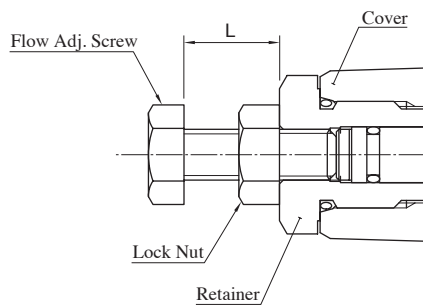

A3HG Series High Pressure Variable Displacement Piston Pumps

A3HG Series

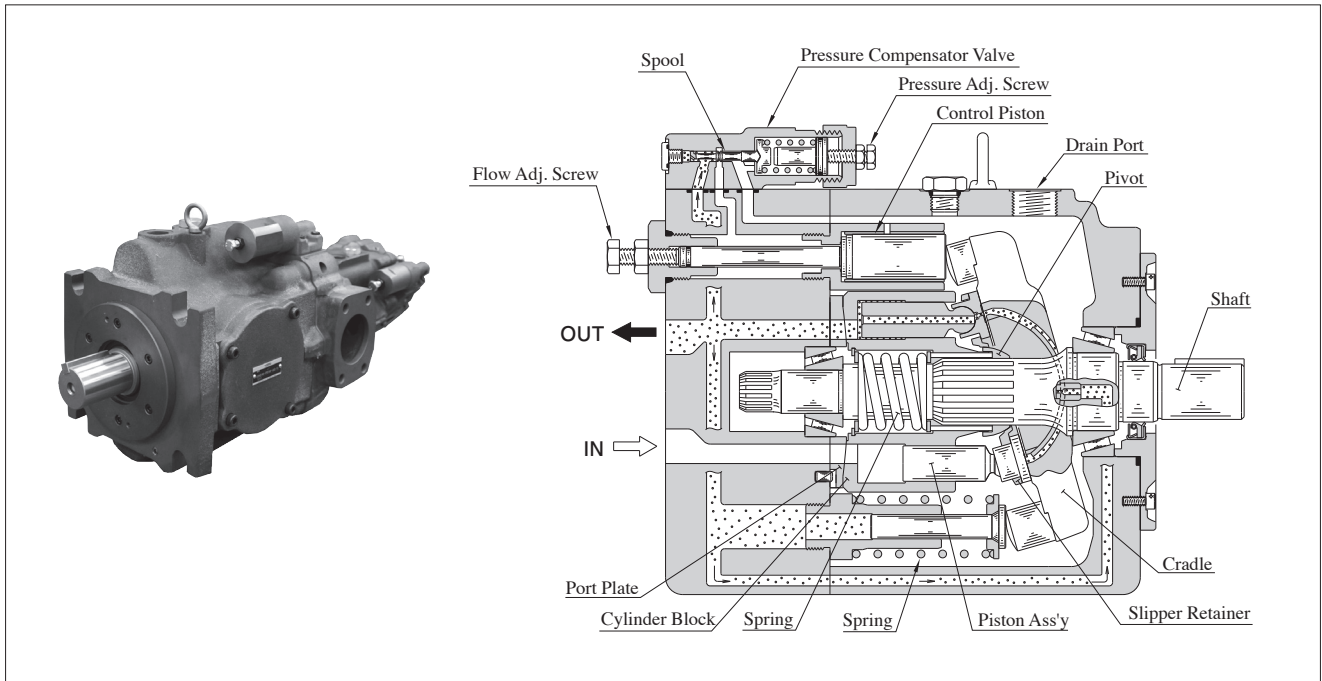

Features

Conforming to International Standards

We have widened the range and now have available pumps not only with JIS mounting but also ISO 3019-2 and ISO 3019-1 variants as standard depending on market needs.

Both keyed shaft and spline shaft are available as standard design.

Mounting

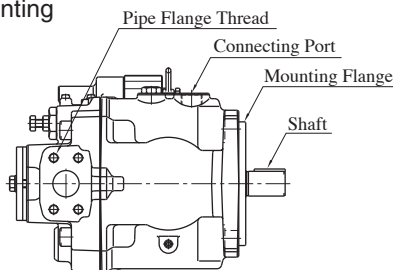

Frage/Port Code	Pipe Flange Thread	Connecting Port	Mounting Flange and Shaft
E1	Metric	Metric	Conforms to ISO 3019-2
U1	Unified	Unified	Conforms to ISO 3019-1
U2	Metric	BSPP	Conforms to ISO 3019-1
J1	Metric	Rc	Conforms to ISO 3019-1

Shaft Extension

Keyed



Spline



High Pressure and Wide Flow Range

Maintaining the high performance of our A3H pumps, the improved A3HG series now offers a nominal pressure of 31.5 MPa.

With a wide flow range, varying from 16.3 cm³/rev to 180.7 cm³/rev.

Supporting a wide range of applications as mid-high load capacity pumps.

Through-drive System Adopted as A Standard Feature

The through-drive system adopted as a standard feature allows connecting a pump having the same capacity as the driving pump on the driven side, increasing the maximum flow range. Any pump conforming to international standards can be used on the driven side; replacement in machines can be readily done.

Wide Variety of Control Modes

Four control modes are available to support various functions:

pressure compensator type, pilot pressure control type pressure compensator, constant power control type with external pilot and load sensing type.

Control Type

Control Type	Graphic Symbols	Performance Characteristics	Explanation	Page
<p>“01” Pressure Compensator Type</p>			<ul style="list-style-type: none"> When the system pressure increases and comes close to the preset cut-off pressure, the pump flow decreases automatically while maintaining the set pressure as it is. The output flow and full cut-off pressure can be manually adjusted. 	A-153
<p>“07” Pilot Pressure Control Type Pressure Compensator</p>			<p>The pump is used in combination with the pilot relief valve or multistage pressure control valve. By controlling the pilot pressure, the full cut-off pressure can be remote-controlled according to your requirements.</p>	A-172
<p>“09V” Constant Power Control Type With External Pilot</p>			<ul style="list-style-type: none"> This type of control can control the pump input power according to the motor output. When the system pressure increases, the output flow decreases, in correspondence to predetermined shaft input values. This type of control can enable one pump to act as two pumps (low-pressure and large-flow/high-pressure and small-flow). Therefore, the motor capacity can be reduced. This type of control provides the remote control of the full cut-off pressure by connecting a remote control relief valve to the pilot port “PP”. 	A-179
<p>“14” Load Sensing Type</p>			<ul style="list-style-type: none"> This is an energy-saving type control which maintains the pump flow and load pressure at the absolute minimum necessary level to operate the actuator. This type of control automatically regulates the output flow so that the inlet-outlet differential pressure of the flow control valve at the output side is constant. To do so, the load pressure must be introduced to the load sensing port “L” of the pump through the external piping. This type of control provides the remote control of the full cut-off pressure by connecting a remote control relief valve to the pilot port “PP”. 	A-186

★ A flow control valve is not included with the pump. Install the valve separately.

Availability of Control Type

Mark “○” in the table below refers to standard model.

Model Numbers	Geometric Displacement cm ³ /rev	Control Type			
		“01”	“07”	“09V”	“14”
A3HG16	16.3	○	○		○
A3HG37	37.1	○	○	○	○
A3HG56	56.3	○	○	○	○
A3HG71	70.7	○	○	○	○
A3HG100	100.5	○	○	○	○
A3HG145	145.2	○	○	○	○
A3HG180	180.7	○	○	○	○

A3HG Series High Pressure Variable Displacement Piston Pumps Pressure Compensator Type

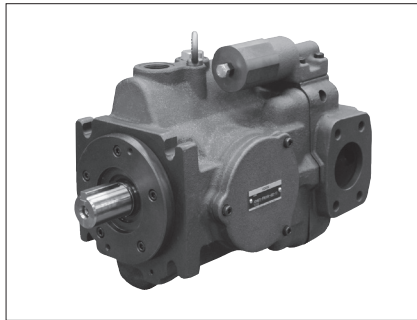

Graphic Symbol

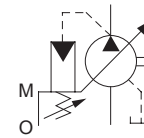

Specifications

Model Numbers	Geometric Displacement cm ³ /rev	Minimum Adjustment Flow cm ³ /rev	Operating Pressure MPa		Shaft Speed Range r/min		Approx. Mass kg		
			Rated ^{★1}	Intermittent	Max. ^{★2}	Min.	Flange Mtg.	Foot Mtg.	
A3HG16- *R01K * - *C-10	16.3	8	31.5	35	3600	600	17	21	
A3HG37- *R01K * - *C-10	37.1	16			2700	600	26.5	35	
A3HG37- *R01K * - *D-10								34	
A3HG56- *R01K * - *C-10	56.3	35			2500	600	34.5	43	
A3HG56- *R01K * - *D-10								32.5	40
A3HG71- *R01K * -E1D/E2D-10	70.7	45			2300	600	45	71	
A3HG71- *R01K * -U1D/U2D/J1D-10								41.5	49
A3HG100- *R01KK-E1D/E2D-10	100.5	63			2100	600	56.5	81.5	
A3HG100- *R01KSP * -E1D/E2D-10								56	81
A3HG100- *R01K * -U1D/U2D/J1D-10								56	83
A3HG145- *R01KK-E1D/E2D-10	145.2	95			1800	600	68.5	94.5	
A3HG145- *R01KSP * -E1D/E2D-10								68	94
A3HG145- *R01K * -U1D/U2D/J1D-10								68	95.5
A3HG180- *R01KK-E1D/E2D-10	180.7	130			1800	600	88	114	
A3HG180- *R01KSP * -E1D/E2D-10								87.5	113.5
A3HG180- *R01KK-U1D/U2D/J1D-10								87.5	115

★1. Consult Yuken when pump is used over rated pressure because there is a restriction on operating condition.

★2. The maximum shaft speeds shown in the above table are at suction pressure 0 kPa.

Model Number Designation

A3HG16	-F	R	01	K	K	-E1					D	-10					
Series Number	Mounting	Direction of Rotation	Control Type	Pres. Adj. Range MPa	Shaft Extension	Main Pump Mtg. Flange Connecting Port / Pipe Flange Thread Second Pump Mtg.					Number of Pump Mtg. Bolts	Design Number					
A3HG16 (16.3 cm ³ /rev)	F: Flange Mtg. L: Foot Mtg.	(Viewed from Shaft End) R: Clockwise (Normal)	01: Pressure Compensator Type	K: 5 - 35	K: Keyed Shaft SP: Splined Shaft (High Torque) SP1: Splined Shaft (Conforms to ISO 3019-1)	Code	Main Pump Mtg. Flange	Connecting Port	Pipe Flange Thread	Second Pump Mtg.	C: 2 D: 4 D: 4	10 10 10 10 10					
A3HG37 (37.1 cm ³ /rev)													E1	ISO 3019-2	Metric	Metric	ISO 3019-2
A3HG56 (56.3 cm ³ /rev)													E2	ISO 3019-2	Metric	Metric	ISO 3019-1
A3HG71 (70.7 cm ³ /rev)													U1	ISO 3019-1	Unified	Unified	ISO 3019-1
A3HG100 (100.5 cm ³ /rev)													U2	ISO 3019-1	BSPP	Metric	ISO 3019-1
A3HG145 (145.2 cm ³ /rev)													J1	ISO 3019-1	Rc	Metric	ISO 3019-1
A3HG180 (180.7 cm ³ /rev)																	

■ Pipe Flange Kits

Pipe flange mouting surface conforms to SAE J 518, 4 bolt split flange.
 Pipe flange kits are not available. Contact us for the details.

Response Characteristics Change in Accordance with Circuits and Operating Conditions.

■ Test Circuit and Conditions

● Circuit

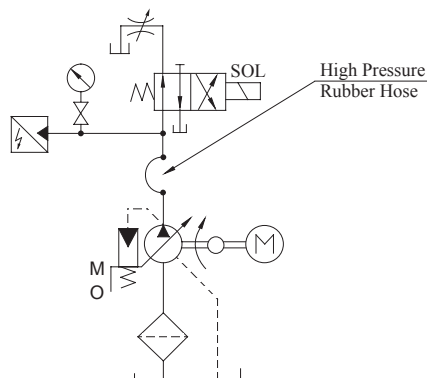

● Size of High Pressure Rubber Hose

Model	High Pressure Rubber Hose
A3HG16	3/4B × 1500 mm
A3HG37/56/71	3/4B × 2000 mm
A3HG100/145	1-1/4B × 2000 mm
A3HG180	1-1/4B × 2500 mm

● Conditions

Drive Speed : 1500 r/min
 Hydraulic Fluid : ISO VG32 Oil
 Oil Temperature: 40°C [Viscosity 32 mm²/s]

■ Result of Measurement

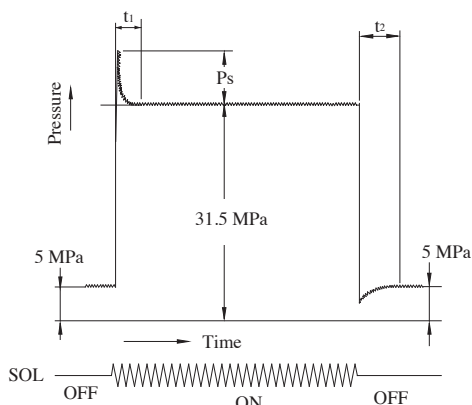

Model	Response Time ms		Overshoot Pressure Ps MPa
	t_1	t_2	
A3HG16	130	140	2.5
A3HG37	95	70	4.0
A3HG56	105	90	7.5
A3HG71	80	125	9.5
A3HG100	85	140	11.0
A3HG145	85	150	12.0
A3HG180	95	230	16.0

Typical Performance Characteristics of Type **A3HG16** at Viscosity 32 mm²/s [ISO VG32 Oils, 40°C]

Performance Characteristic Curve

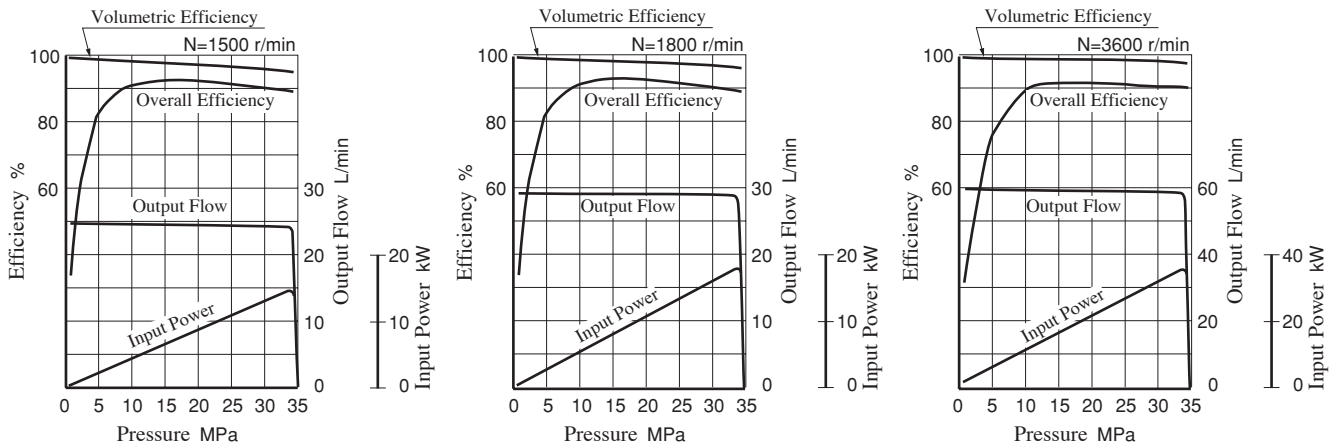

Input Power

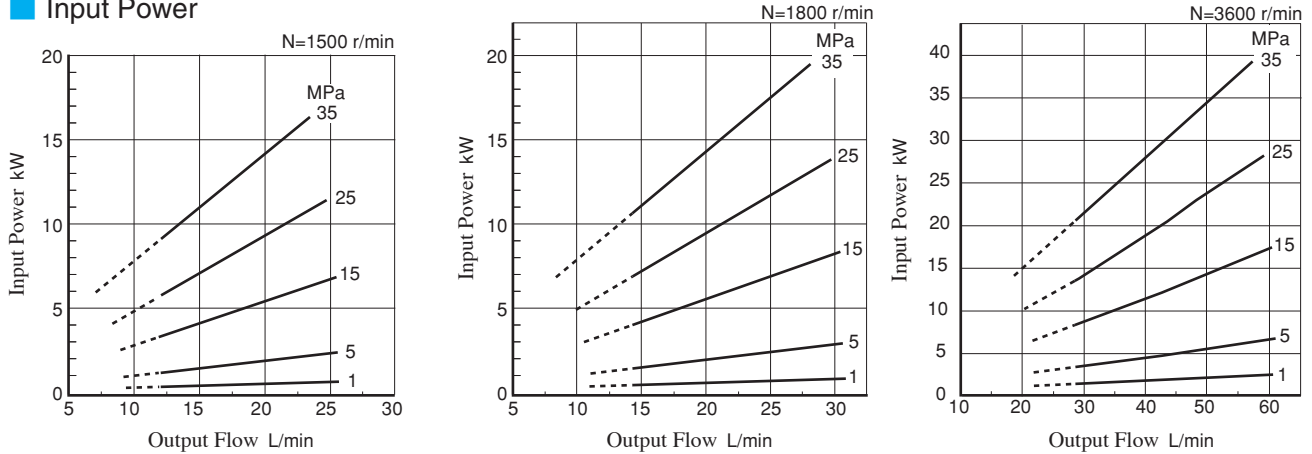

★ The dotted line in the graph indicates less than minimum adjustable flow.

Full Cut-off Power

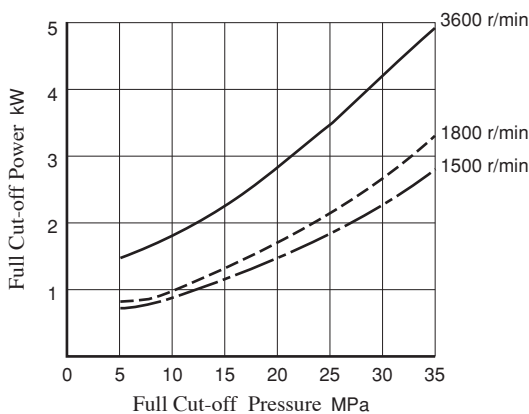

Drain

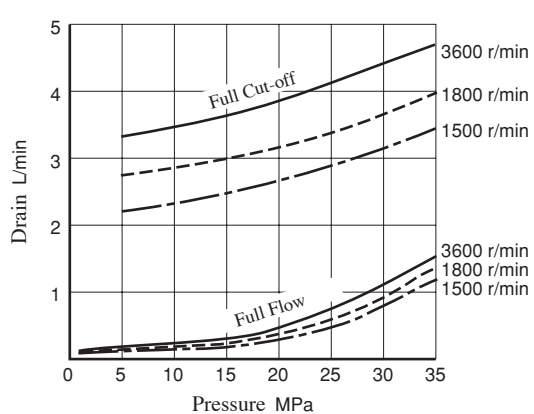

Noise Level [One meter horizontally away from pump head cover]

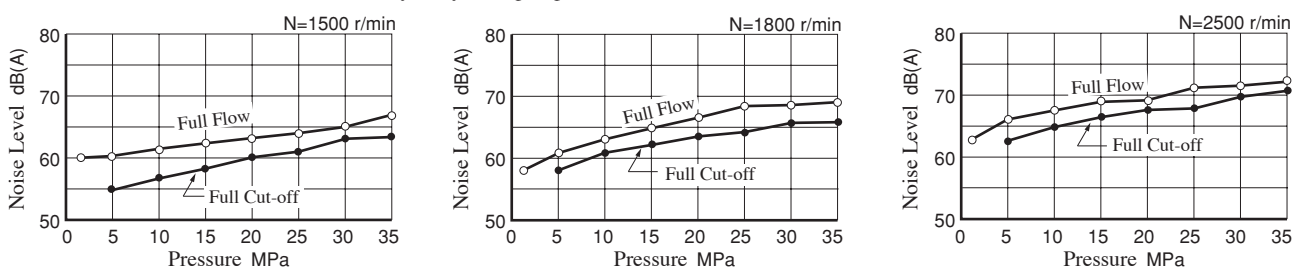

Typical Performance Characteristics of Type **A3HG37** at Viscosity 32 mm²/s [ISO VG32 Oils, 40°C]

Performance Characteristic Curve

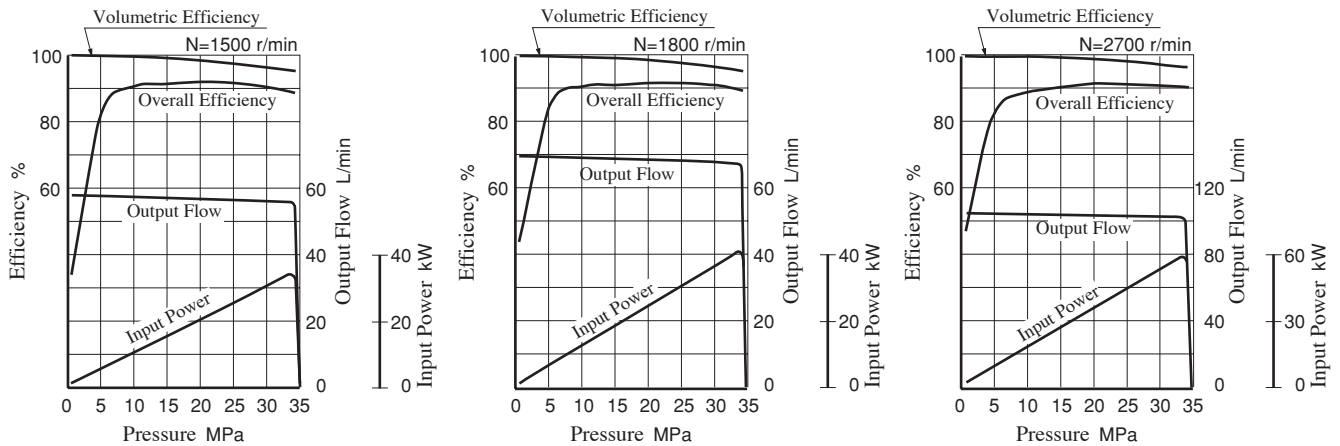

Input Power

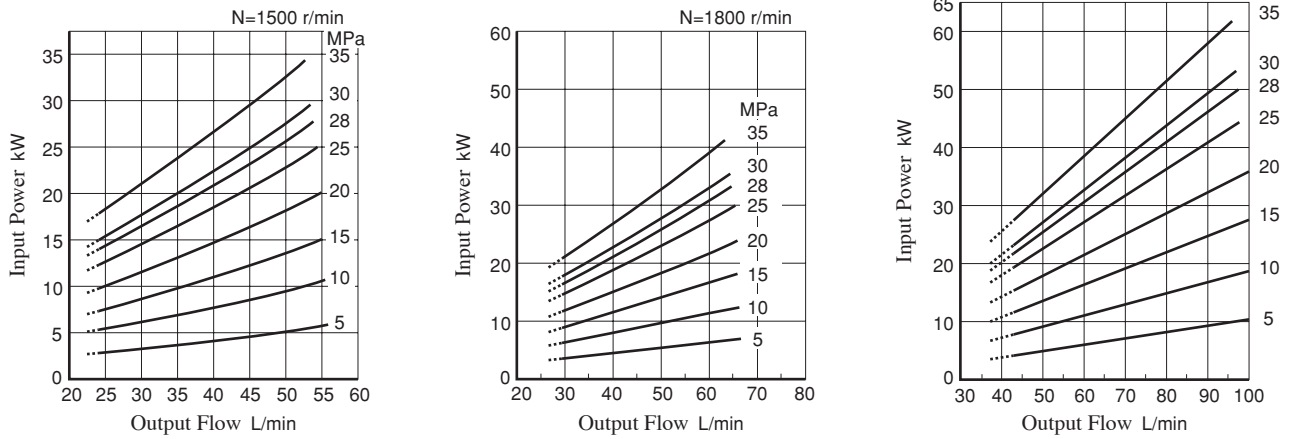

★ The dotted line in the graph indicates less than minimum adjustable flow.

Full Cut-off Power

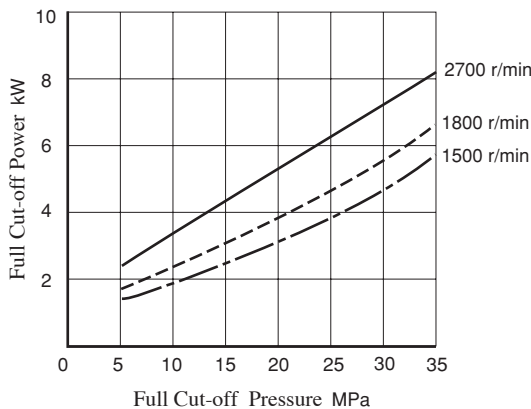

Drain

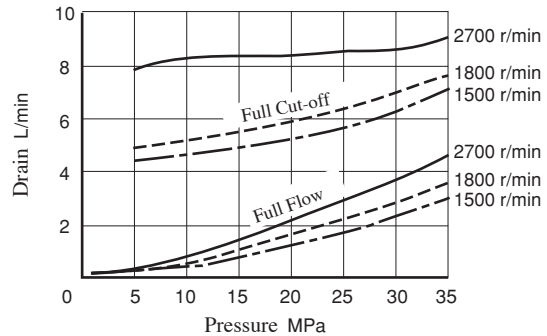

Noise Level [One meter horizontally away from pump head cover]

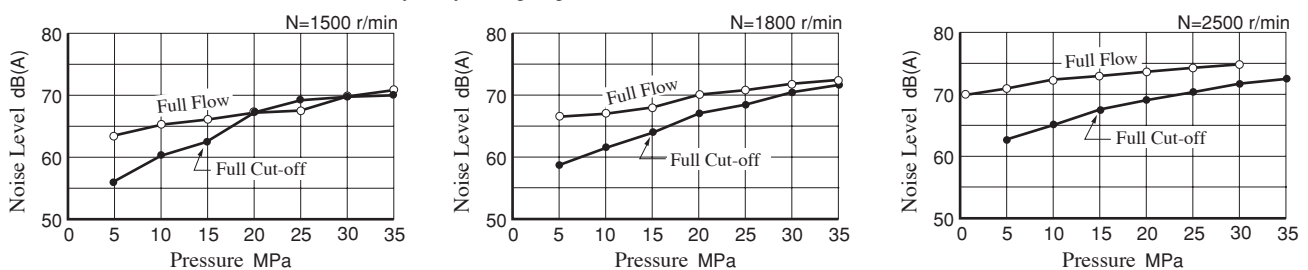

Typical Performance Characteristics of Type **A3HG56** at Viscosity 32 mm²/s [ISO VG32 Oils, 40°C]

Performance Characteristic Curve

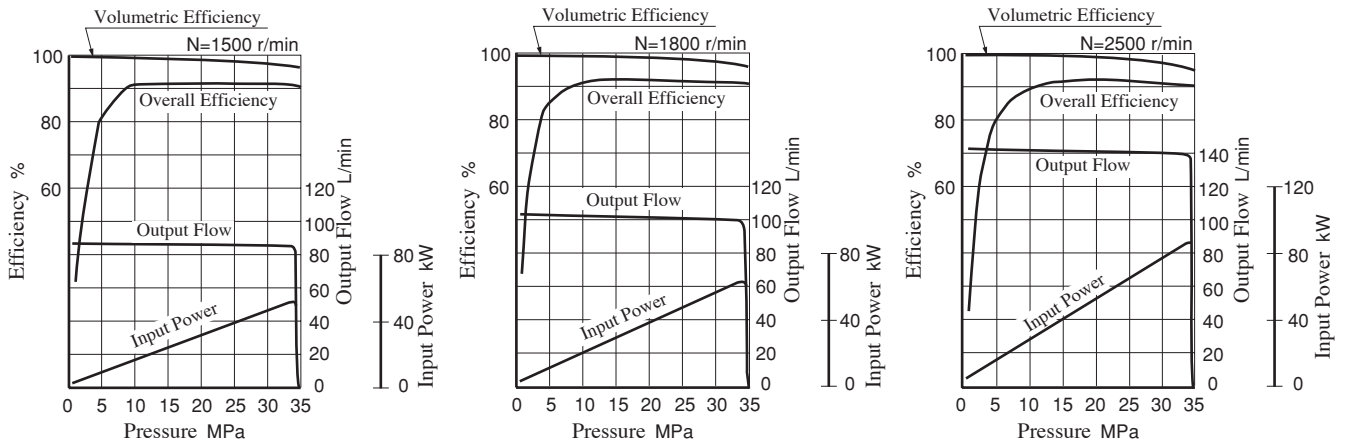

Input Power

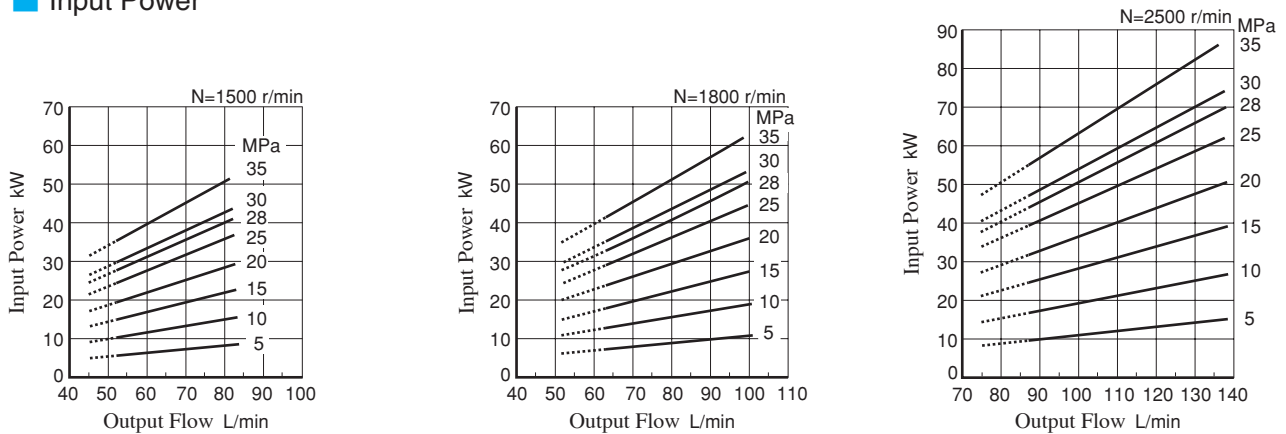

★ The dotted line in the graph indicates less than minimum adjustable flow.

Full Cut-off Power

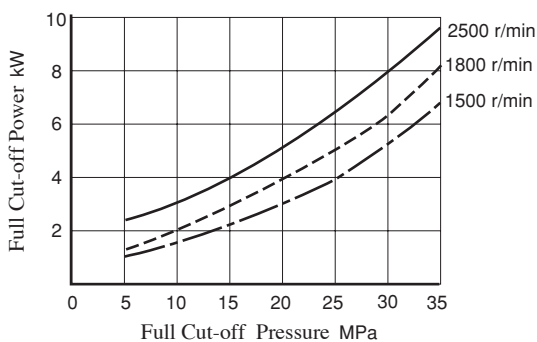

Drain

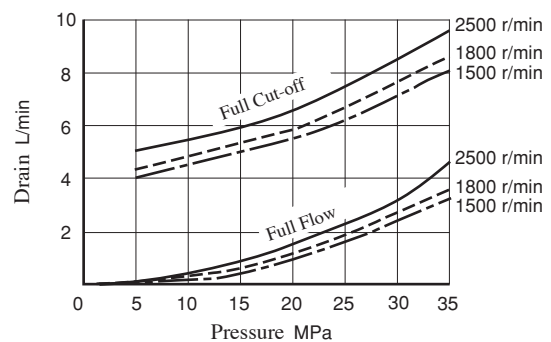

Noise Level [One meter horizontally away from pump head cover]

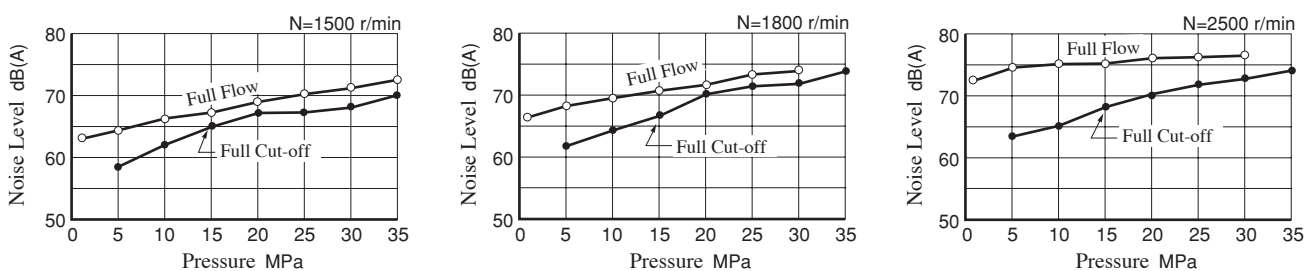

Typical Performance Characteristics of Type **A3HG71** at Viscosity 32 mm²/s [ISO VG32 Oils, 40°C]

Performance Characteristic Curve

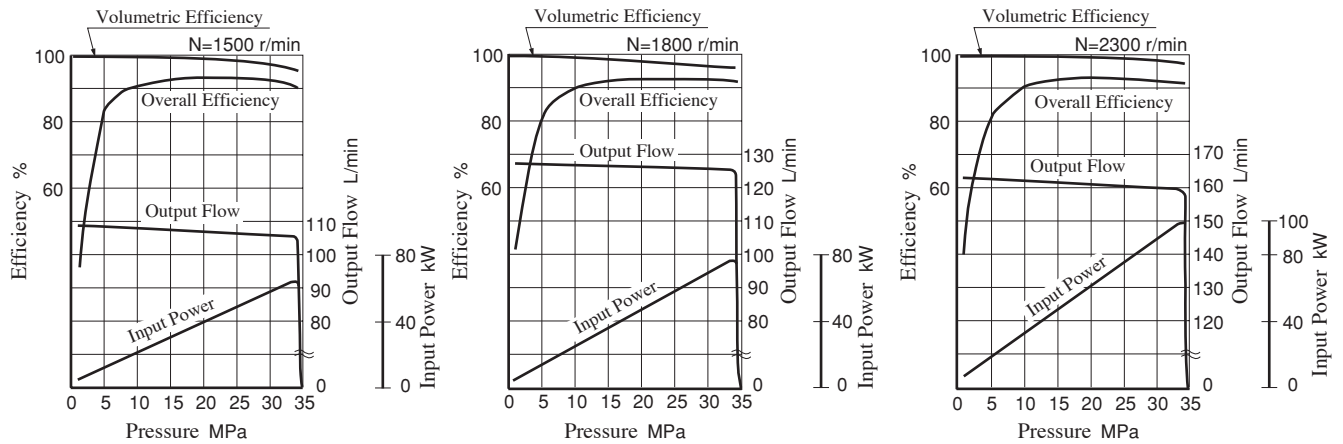

Input Power

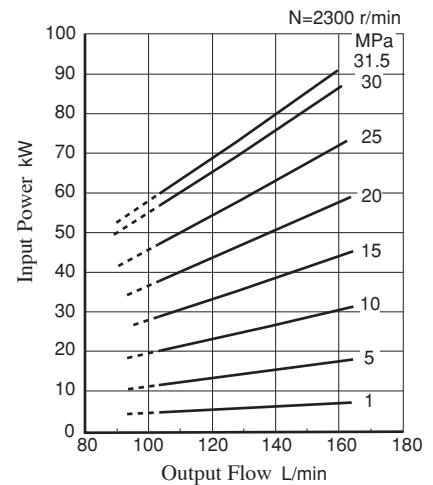
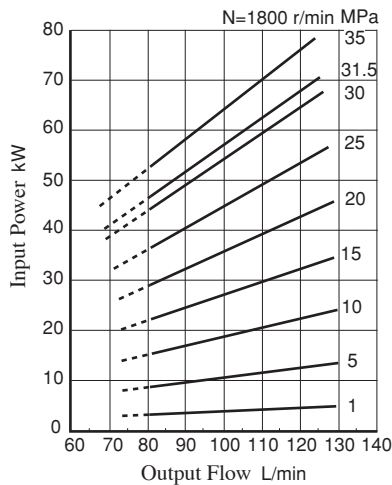
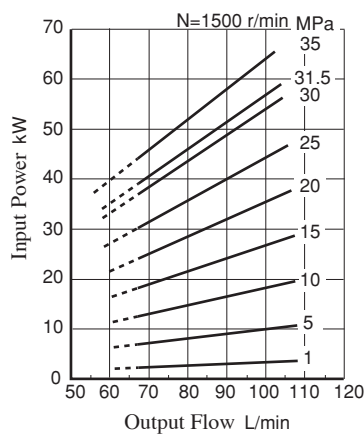

★ The dotted line in the graph indicates less than minimum adjustable flow.

Full Cut-off Power

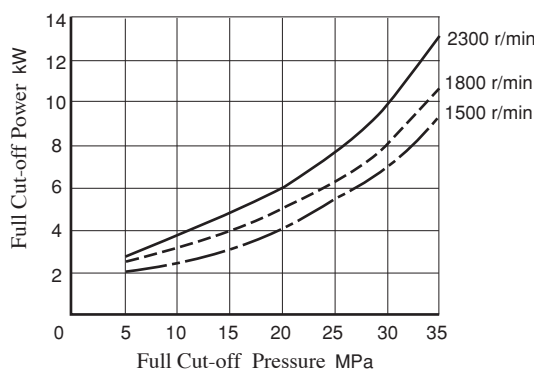

Drain

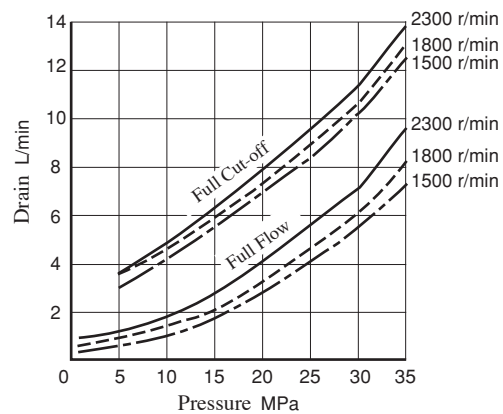

Noise Level [One meter horizontally away from pump head cover]

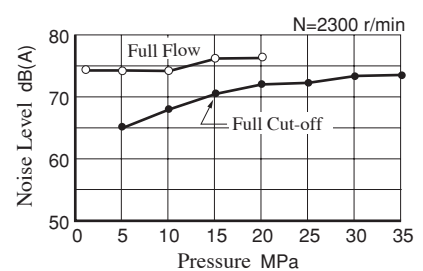
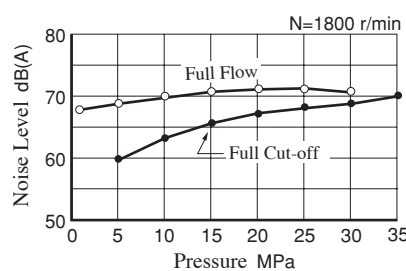
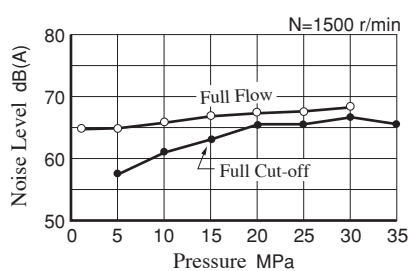

Typical Performance Characteristics of Type **A3HG100** at Viscosity 32 mm²/s [ISO VG32 Oils, 40°C]

Performance Characteristic Curve

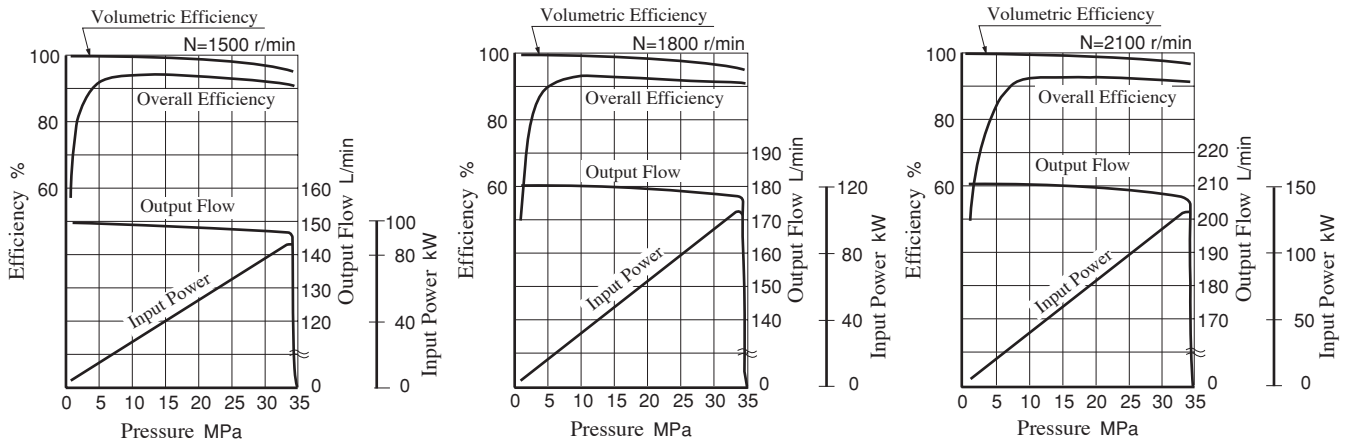

Input Power

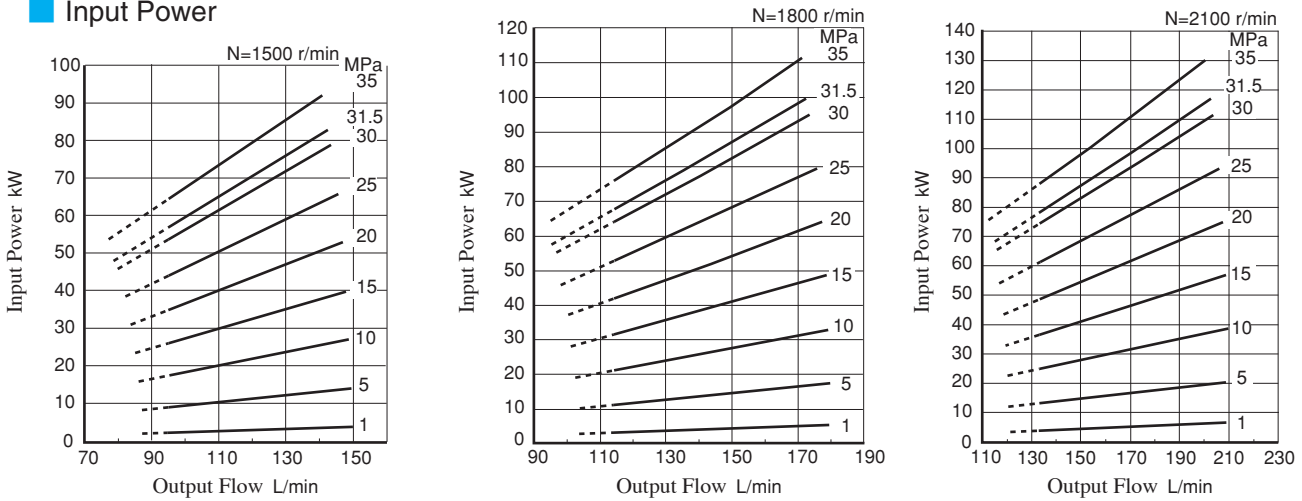

★ The dotted line in the graph indicates less than minimum adjustable flow.

Full Cut-off Power

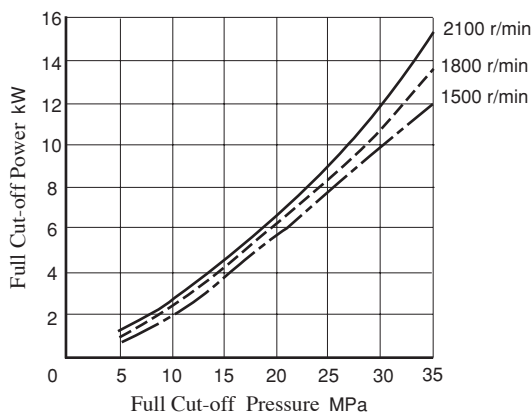

Drain

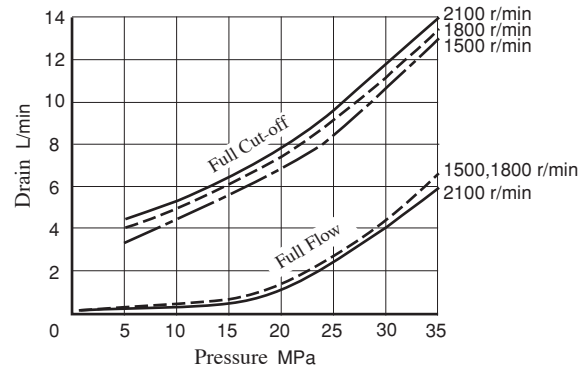

Noise Level [One meter horizontally away from pump head cover]

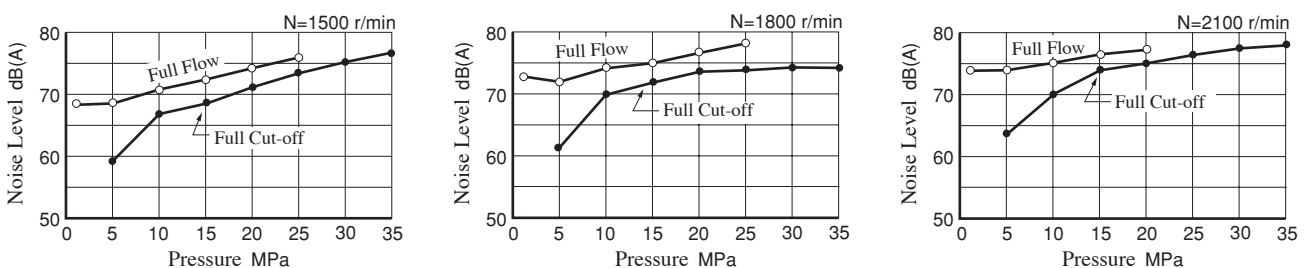

Typical Performance Characteristics of Type **A3HG145** at Viscosity 32 mm²/s [ISO VG32 Oils, 40°C]

Performance Characteristic Curve

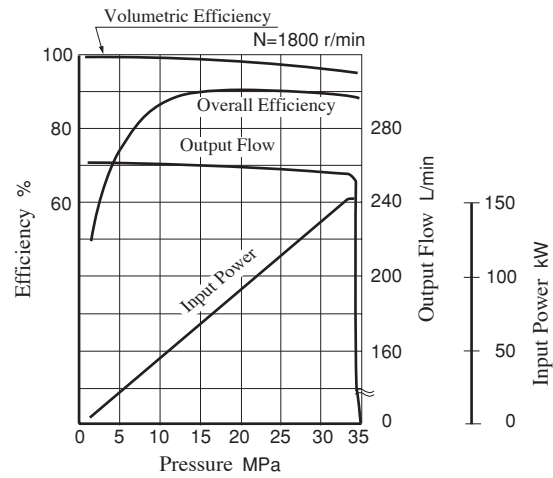
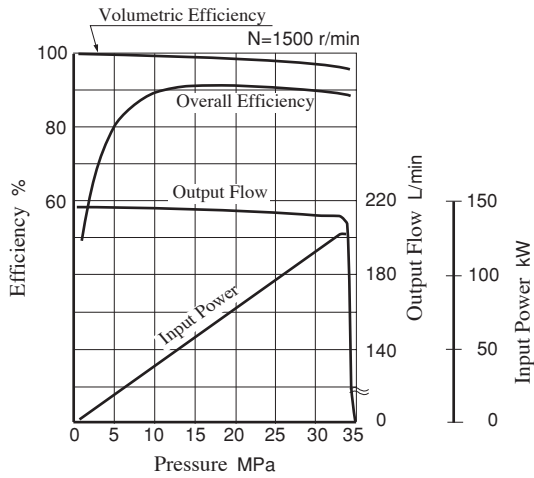

Input Power

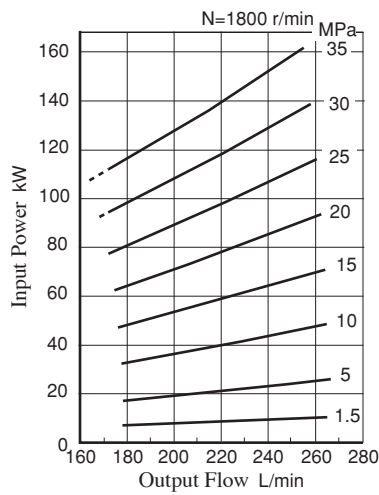
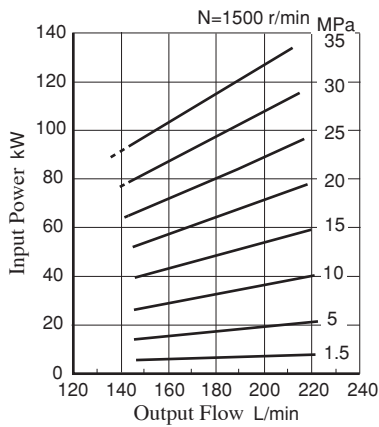

★ The dotted line in the graph indicates less than minimum adjustable flow.

Full Cut-off Power

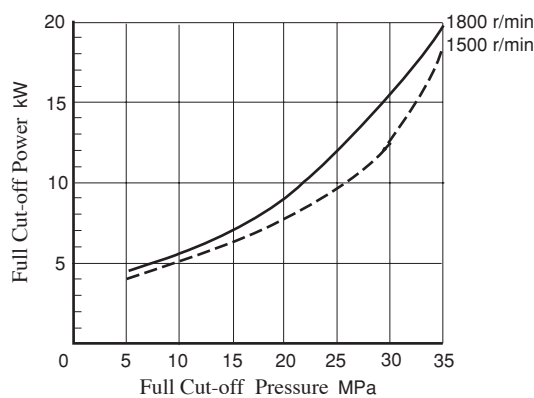

Drain

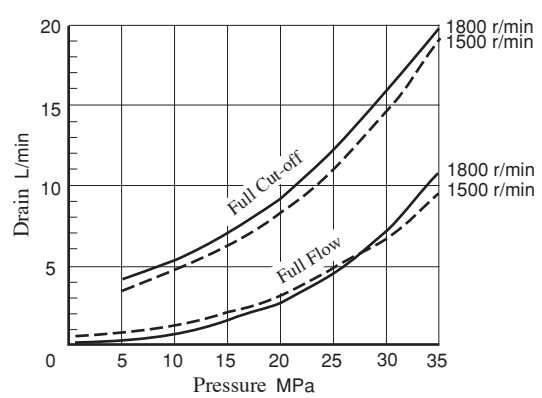

Noise Level [One meter horizontally away from pump head cover]

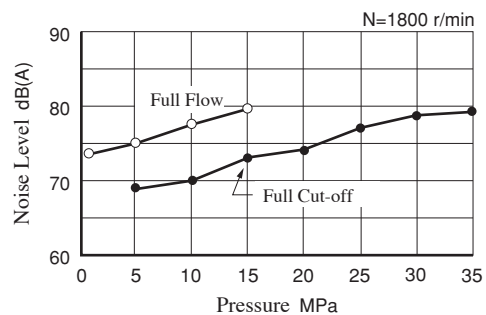
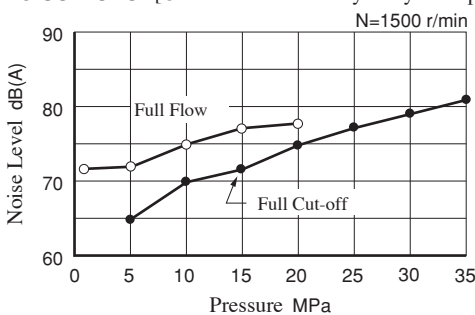

Typical Performance Characteristics of Type **A3HG180** at Viscosity 32 mm²/s [ISO VG32 Oils, 40°C]

Performance Characteristic Curve

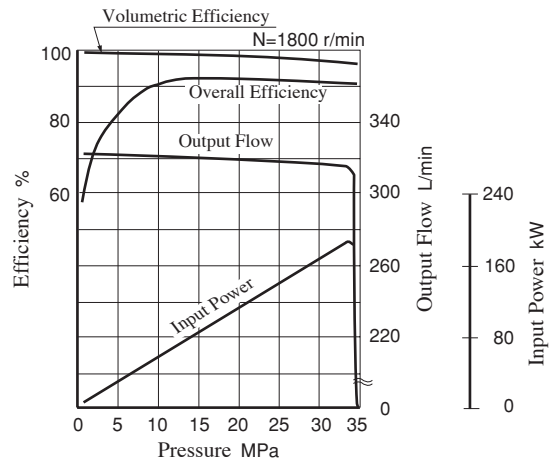
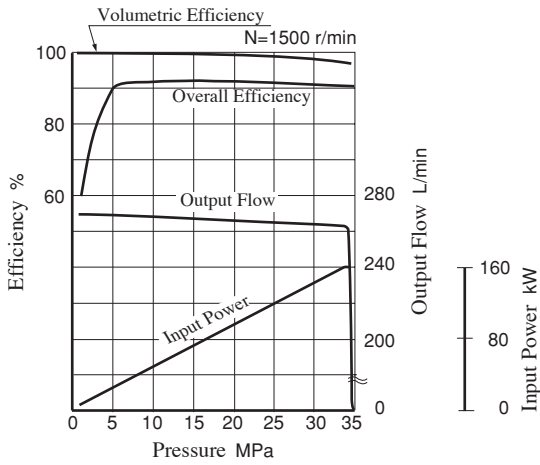

Input Power

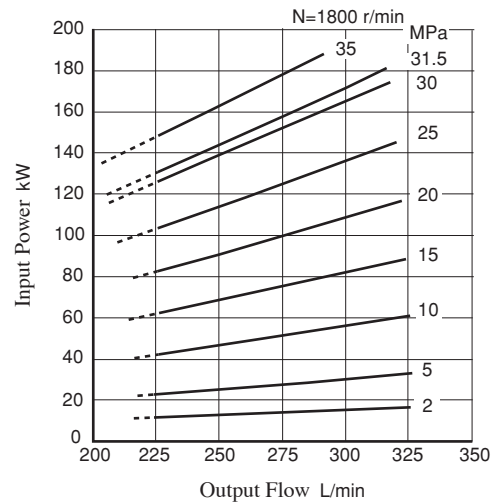
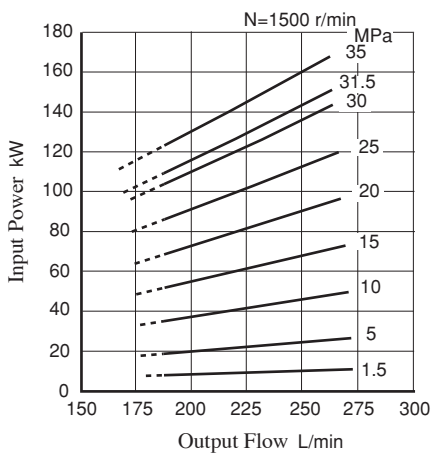

★ The dotted line in the graph indicates less than minimum adjustable flow.

Full Cut-off Power

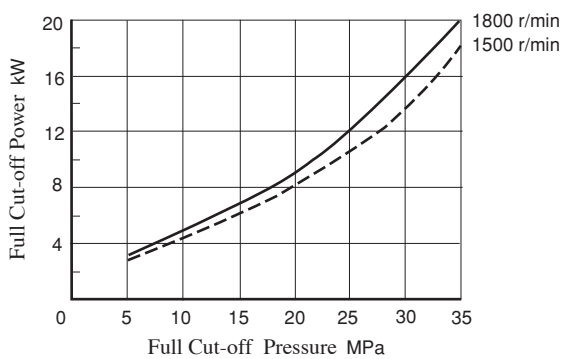

Drain

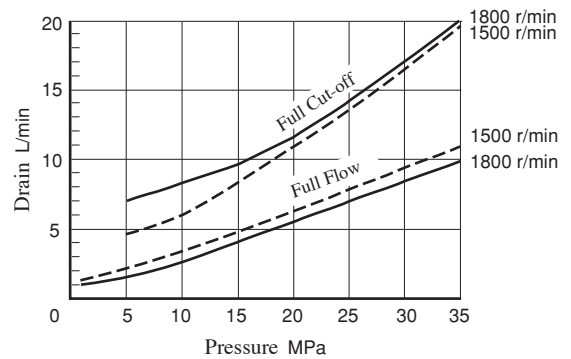

Noise Level [One meter horizontally away from pump head cover]

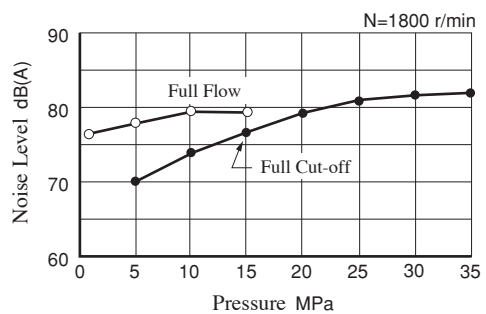
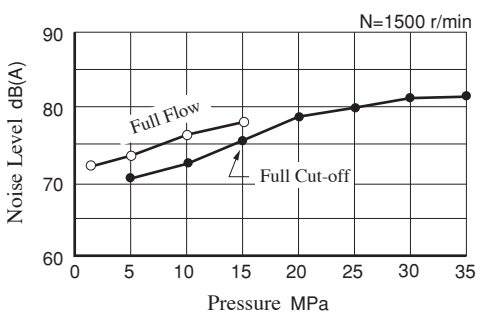

Flange Mtg.:A3HG16-FR01KK-E1C/U1C/U2C/J1C

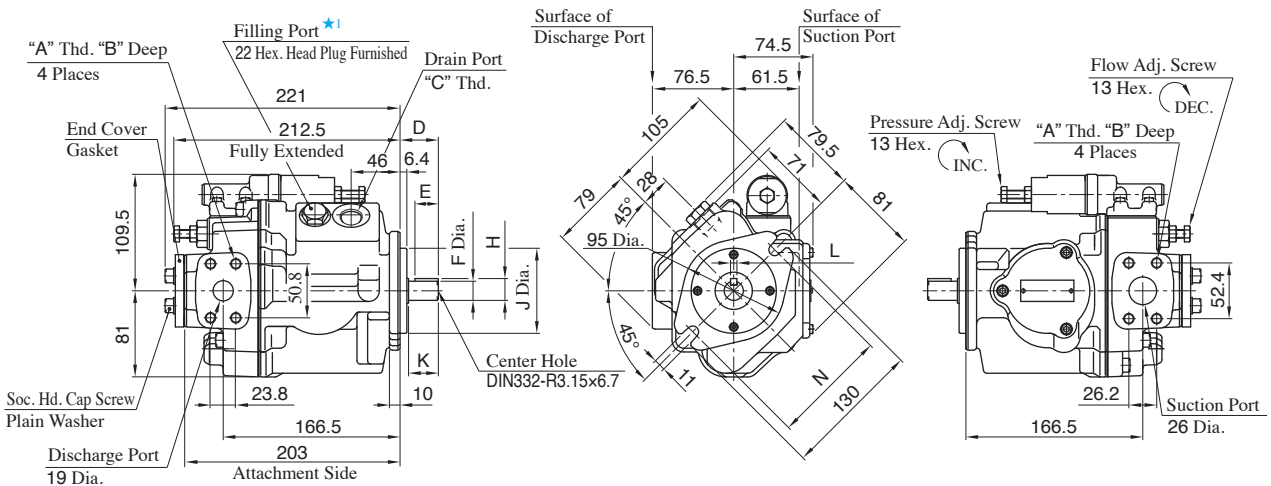

★1. Install the pump so that the "Filling Port" is at the top.

Model Numbers	A	B	C	D	E	F	H	J	K	L	N	Mounting Flange	Connecting Port	Pipe Flange Threads
A3HG16-FR01KK-E1C	M10	19	M22X1.5	36	22	18 ^{+0.008} _{-0.003}	20.5 ^{+0.008} _{-0.133}	80 ⁰ _{-0.046}	28	6 ⁰ _{-0.03}	109	Conforms to ISO 3019-2	Metric	Metric
A3HG16-FR01KK-U1C	3/8-16 UNC	17	G 1/2	41	28	19.05 ⁰ _{-0.03}	21.24 ⁰ _{-0.16}	82.55 ⁰ _{-0.05}	33	4.76 ^{+0.03} ₀	106	Conforms to ISO 3019-1	Unified	Unified
A3HG16-FR01KK-U2C	M10	19	G 1/2	41	28	19.05 ⁰ _{-0.03}	21.24 ⁰ _{-0.16}	82.55 ⁰ _{-0.05}	33	4.76 ^{+0.03} ₀	106	Conforms to ISO 3019-1	BSPP	Metric
A3HG16-FR01KK-J1C	M10	19	G 1/2	41	28	19.05 ⁰ _{-0.03}	21.24 ⁰ _{-0.16}	82.55 ⁰ _{-0.05}	33	4.76 ^{+0.03} ₀	106	Conforms to ISO 3019-1	Rc	Metric

Drain Port

For port/flange code "U1/J1", adapter and bonded seal are attached. After installing the bonded seal at the drain port tighten the adapter.

Detail:A3HG16-FR01KK-E1C

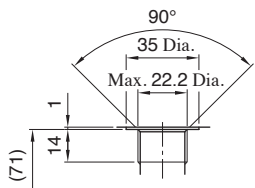

Detail of Drain Port ★2

★2. Drain port conforms to ISO 9974-1, metric threads.

Accessories:A3HG16-FR01KK-U1C

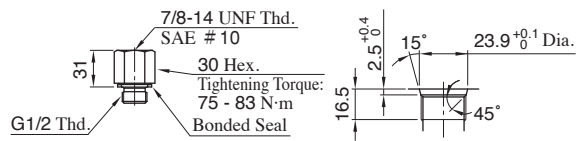

Adapter

Detail of Adapter Port ★3

★3. Adapter port conforms to SAE J 514, O-ring seals.

Detail:A3HG16-FR01KK-U2C

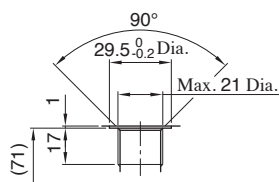

Detail of Drain Port ★4

★4. Drain port conforms to ISO 1179-1, BSPP threads.

Accessories:A3HG16-FR01KK-J1C

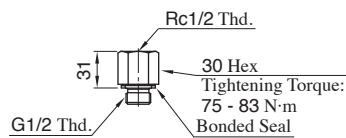

Adapter

Foot Mtg.:A3HG16-LR01KK-E1C/U1C/U2C/J1C

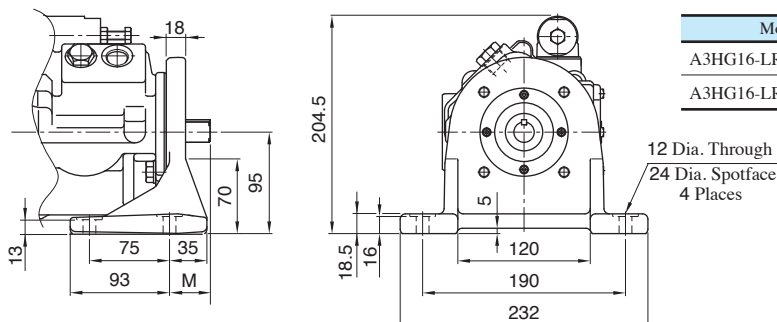

Model Numbers	M
A3HG16-LR01KK-E1C	33
A3HG16-LR01KK-U1C/U2C/J1C	38

● For other dimensions, refer to "Flange Mtg.".

Flange Mtg. Two Bolts:A3HG37-FR01KK-E1C/E2C/U1C/U2C/J1C

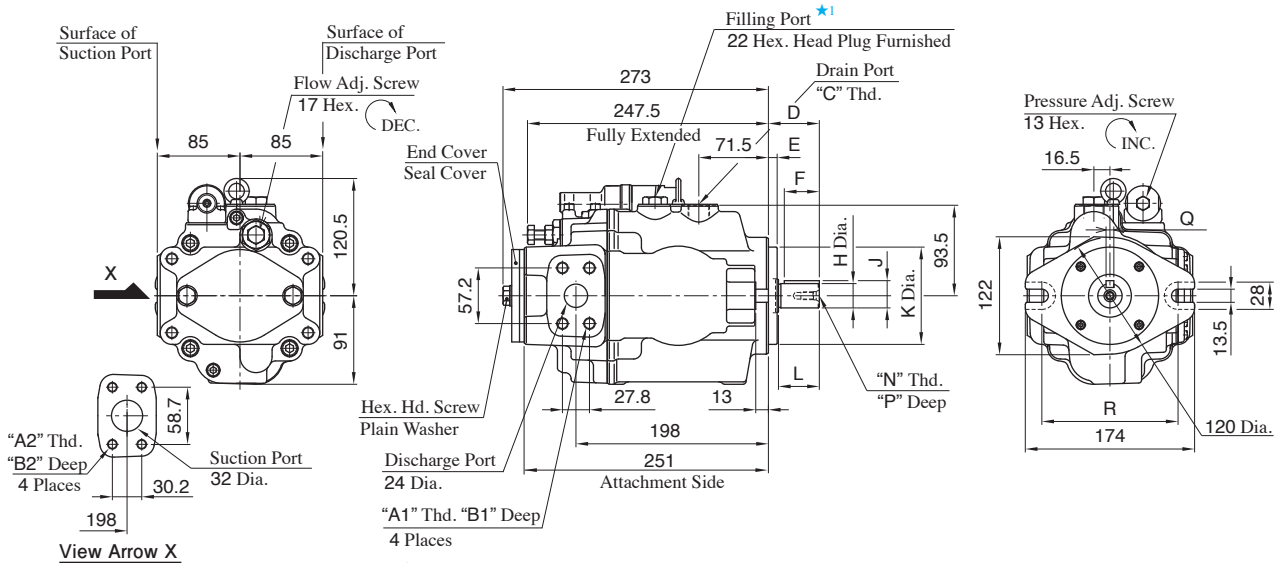

Model Numbers	A1	A2	B1	B2	C	D	E	F	H	J	K	L	N	P	Q	R	Mounting Flange	Connecting Port	Pipe Flange Threads
A3HG37-FR01KK-E1C/E2C	M12	M10	22	18	M22X1.5	52	9	36	25 ^{+0.009} _{-0.004}	28 ^{+0.009} _{-0.294}	100 ⁰ _{-0.054}	42	M8	19	8 ⁰ _{-0.036}	140	Conforms to ISO 3019-2	Metric	Metric
A3HG37-FR01KK-U1C	7/16-14 UNC		20		G 1/2	46	9.7	32	25.4 ⁰ _{-0.05}	28.18 ⁰ _{-0.18}	101.6 ⁰ _{-0.05}	38	1/4	16	6.35 ^{+0.03} ₀	146	Conforms to ISO 3019-1	Unified	Unified
A3HG37-FR01KK-U2C	M12	M10	22	18	G 1/2	46	9.7	32	25.4 ⁰ _{-0.05}	28.18 ⁰ _{-0.18}	101.6 ⁰ _{-0.05}	38	20 UNC	16	6.35 ^{+0.03} ₀	146	Conforms to ISO 3019-1	BSP	Metric
A3HG37-FR01KK-J1C	M12	M10	22	18	G 1/2	46	9.7	32	25.4 ⁰ _{-0.05}	28.18 ⁰ _{-0.18}	101.6 ⁰ _{-0.05}	38		16	6.35 ^{+0.03} ₀	146	Conforms to ISO 3019-1	Rc	Metric

Drain Port

For port/flange code "U1/J1", adapter and bonded seal are attached. After installing the bonded seal at the drain port tighten the adapter.

Detail:A3HG37-FR01KK-E1C/E2C

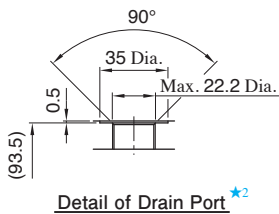

★2. Drain port conforms to ISO 9974-1, metric threads.

Accessories:A3HG37-FR01KK-U1C

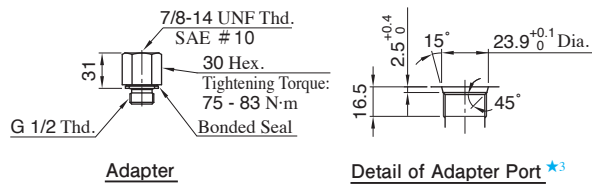

★3. Adapter port conforms to SAE J 514, O-ring seals.

Detail:A3HG37-FR01KK-U2C

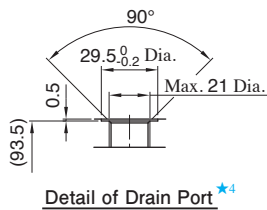

★4. Drain port conforms to ISO 1179-1, BSP threads.

Accessories:A3HG37-FR01KK-J1C

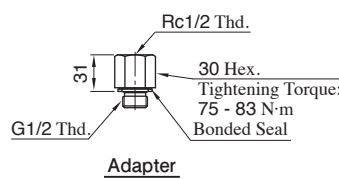

Foot Mtg. Two Bolts:A3HG37-LR01KK-E1C/E2C/U1C/U2C/J1C

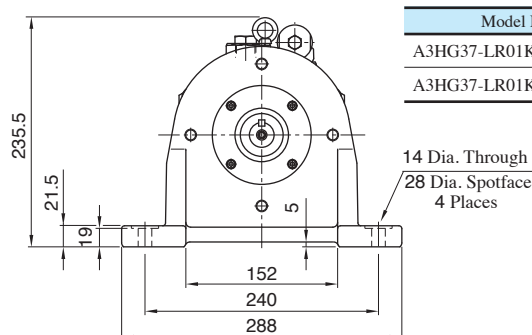
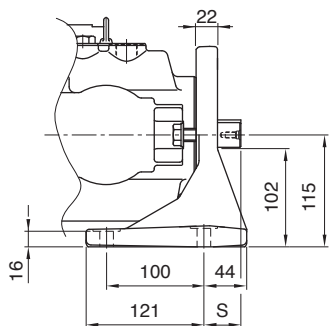

Model Numbers	S
A3HG37-LR01KK-E1C/E2C	44
A3HG37-LR01KK-U1C/U2C/J1C	38

For other dimensions, refer to "Flange Mtg. Two Bolts".

Flange Mtg. Four Bolts:A3HG37-FR01KK-E1D/E2D/U1D/U2D/J1D

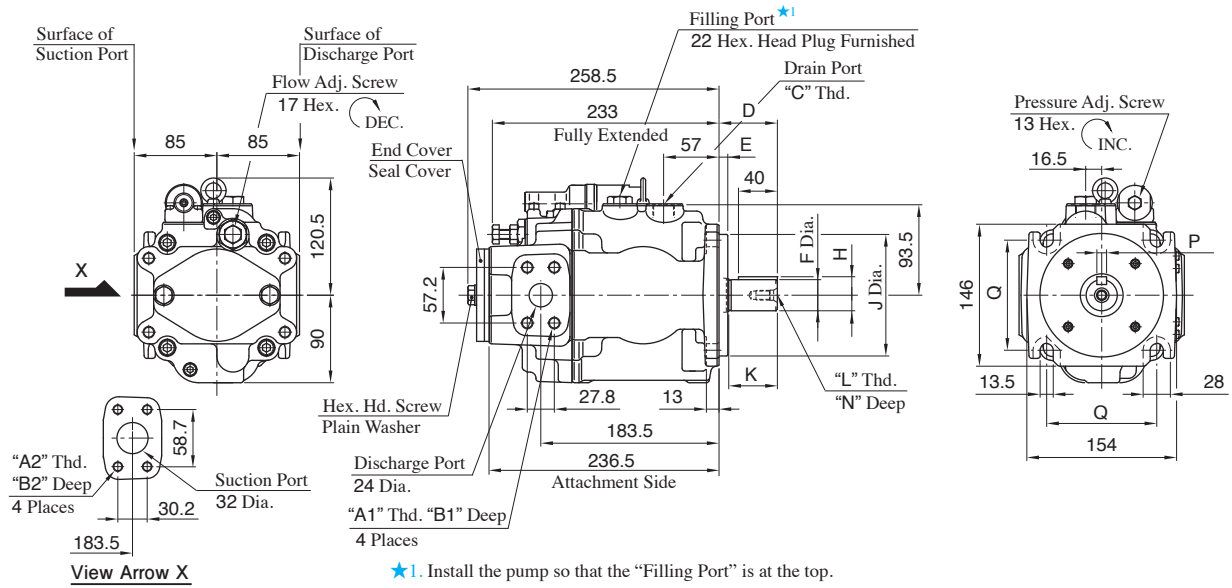

★1. Install the pump so that the "Filling Port" is at the top.

Model Numbers	A1	A2	B1	B2	C	D	E	F	H	J	K	L	N	P	Q	Mounting Flange	Connecting Port	Pipe Flange Threads
A3HG37-FR01KK-E1D/E2D	M12	M10	22	18	M22×1.5	60	9	32 ^{+0.018} _{-0.002}	35 ^{+0.018} _{-0.288}	125 ⁰ _{-0.063}	50	M10	22	10 ⁰ _{-0.036}	113.2	Conforms to ISO 3019-2	Metric	Metric
A3HG37-FR01KK-U1D	7/16-14 UNC		20		G 1/2	56	12.7	31.75 ⁰ _{-0.05}	35.32 ⁰ _{-0.18}	127 ⁰ _{-0.05}	48		19	7.94 ^{+0.03} ₀	114.5	Conforms to ISO 3019-1	Unified	Unified
A3HG37-FR01KK-U2D	M12	M10	22	18	G 1/2	56	12.7	31.75 ⁰ _{-0.05}	35.32 ⁰ _{-0.18}	127 ⁰ _{-0.05}	48	5/16-18 UNC	19	7.94 ^{+0.03} ₀	114.5	Conforms to ISO 3019-1	BSPP	Metric
A3HG37-FR01KK-J1D	M12	M10	22	18	G 1/2	56	12.7	31.75 ⁰ _{-0.05}	35.32 ⁰ _{-0.18}	127 ⁰ _{-0.05}	48		19	7.94 ^{+0.03} ₀	114.5	Conforms to ISO 3019-1	Rc	Metric

Drain Port

For port/flange code "U1/J1", adapter and bonded seal are attached. After installing the bonded seal at the drain port tighten the adapter.

● Detail:A3HG37-FR01KK-E1D/E2D

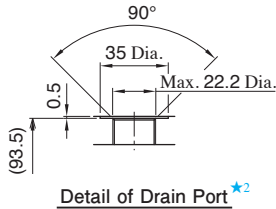

★2. Drain port conforms to ISO 9974-1, metric threads.

● Accessories:A3HG37-FR01KK-U1D

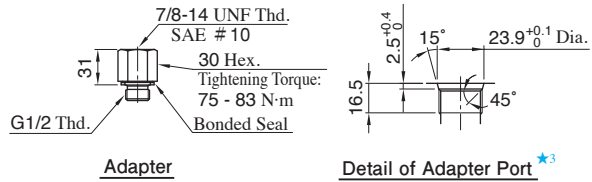

★3. Adapter port conforms to SAE J 514, O-ring seals.

● Detail:A3HG37-FR01KK-U2D

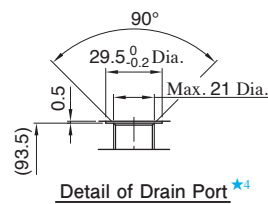

★4. Drain port conforms to ISO 1179-1, BSPP threads.

● Accessories:A3HG37-FR01KK-J1D

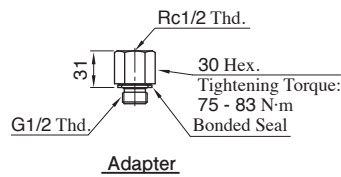

Foot Mtg. Four Bolts:A3HG37-LR01KK-E1D/E2D/U1D/U2D/J1D

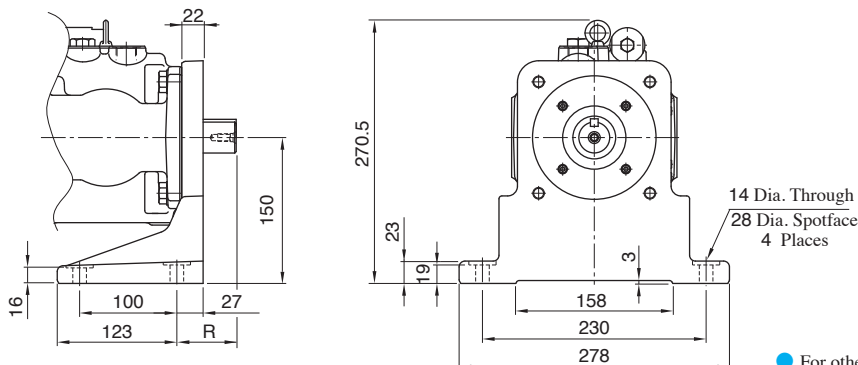

Model Numbers	R
A3HG37-LR01KK-E1D/E2D	65
A3HG37-LR01KK-U1D/U2D/J1D	61

● For other dimensions, refer to "Flange Mtg. Four Bolts".

Flange Mtg. Two Bolts: A3HG56-FR01KK-E1C/E2C/U1C/U2C/J1C

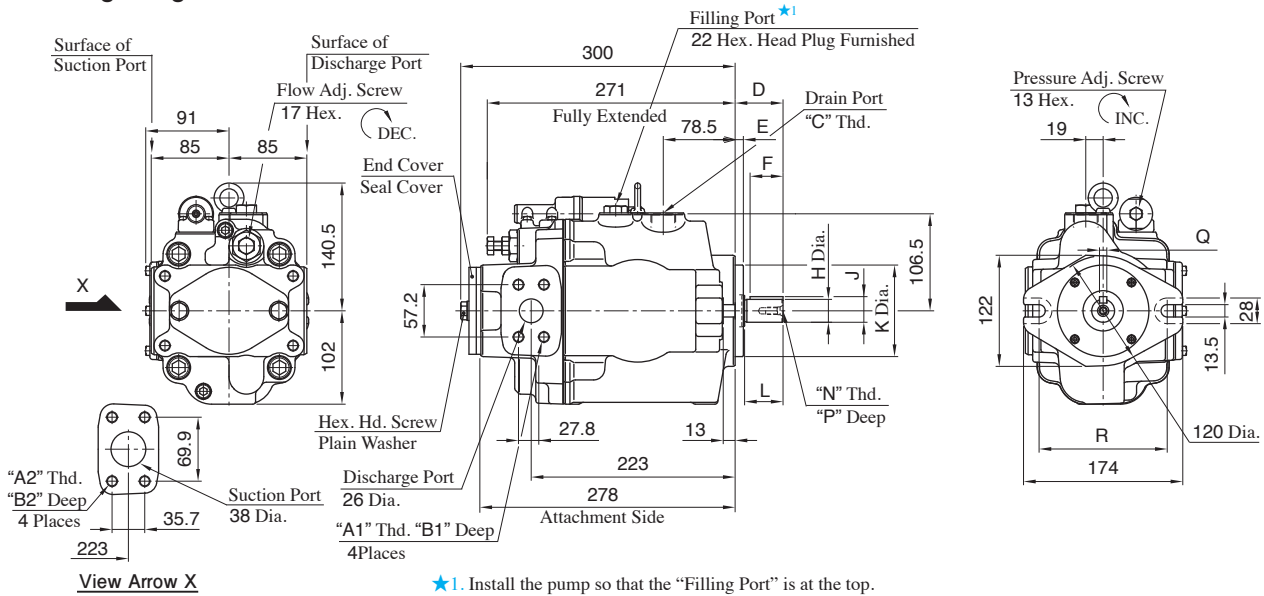

Model Numbers	A1	A2	B1	B2	C	D	E	F	H	J	K	L	N	P	Q	R	Mounting Flange	Connecting Port	Pipe Flange Threads
A3HG56-FR01KK-E1C/E2C	M12	M12	22	22	M27X2	52	9	36	25 ^{+0.009} _{-0.004}	28 ^{+0.009} _{-0.294}	100 ⁰ _{-0.054}	42	M8	19	8 ⁰ _{-0.036}	140	Conforms to ISO 3019-2	Metric	Metric
A3HG56-FR01KK-U1C	7/16-14 UNC	1/2-13 UNC	20	21	G 3/4	46	9.7	32	25.4 ⁰ _{-0.05}	28.18 ⁰ _{-0.18}	101.6 ⁰ _{-0.05}	38	1/4-20 UNC	16	6.35 ^{+0.03} ₀	146	Conforms to ISO 3019-1	Unified	Unified
A3HG56-FR01KK-U2C	M12	M12	22	22	G 3/4	46	9.7	32	25.4 ⁰ _{-0.05}	28.18 ⁰ _{-0.18}	101.6 ⁰ _{-0.05}	38	20 UNC	16	6.35 ^{+0.03} ₀	146	Conforms to ISO 3019-1	BSP	Metric
A3HG56-FR01KK-J1C	M12	M12	22	22	G 3/4	46	9.7	32	25.4 ⁰ _{-0.05}	28.18 ⁰ _{-0.18}	101.6 ⁰ _{-0.05}	38		16	6.35 ^{+0.03} ₀	146	Conforms to ISO 3019-1	Rc	Metric

Drain Port

For port/flange code "U1/J1", adapter and bonded seal are attached. After installing the bonded seal at the drain port tighten the adapter.

Detail: A3HG56-FR01KK-E1C/E2C

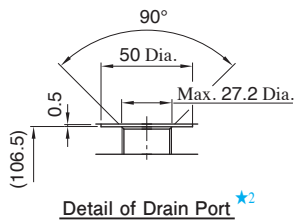

★2. Drain port conforms to ISO 9974-1, metric threads.

Accessories: A3HG56-FR01KK-U1C

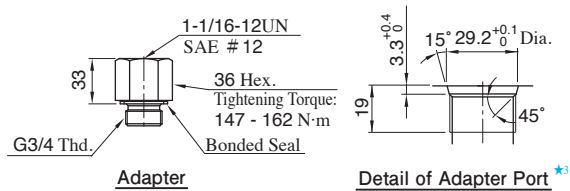

★3. Adapter port conforms to SAE J 514, O-ring seals.

Detail: A3HG56-FR01KK-U2C

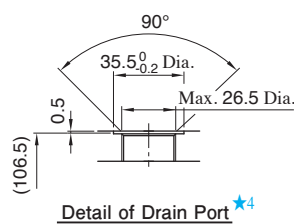

★4. Drain port conforms to ISO 1179-1, BSP threads.

Accessories: A3HG56-FR01KK-J1C

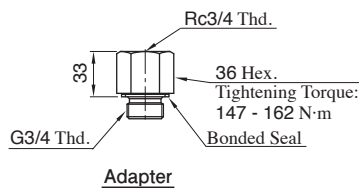

Foot Mtg. Two Bolts: A3HG56-LR01KK-E1C/E2C/U1C/U2C/J1C

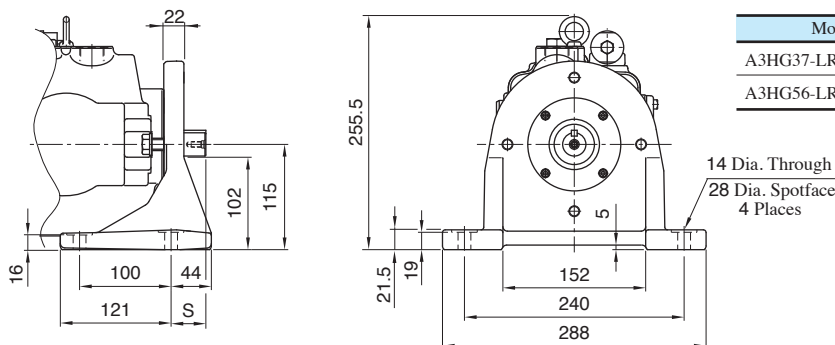

Model Numbers	S
A3HG37-LR01KK-E1C/E2C	44
A3HG56-LR01KK-U1C/U2C/J1C	38

● For other dimensions, refer to "Flange Mtg. Two Bolts".

Flange Mtg. Four Bolts: A3HG56-FR01KK-E1D/E2D/U1D/U2D/J1D

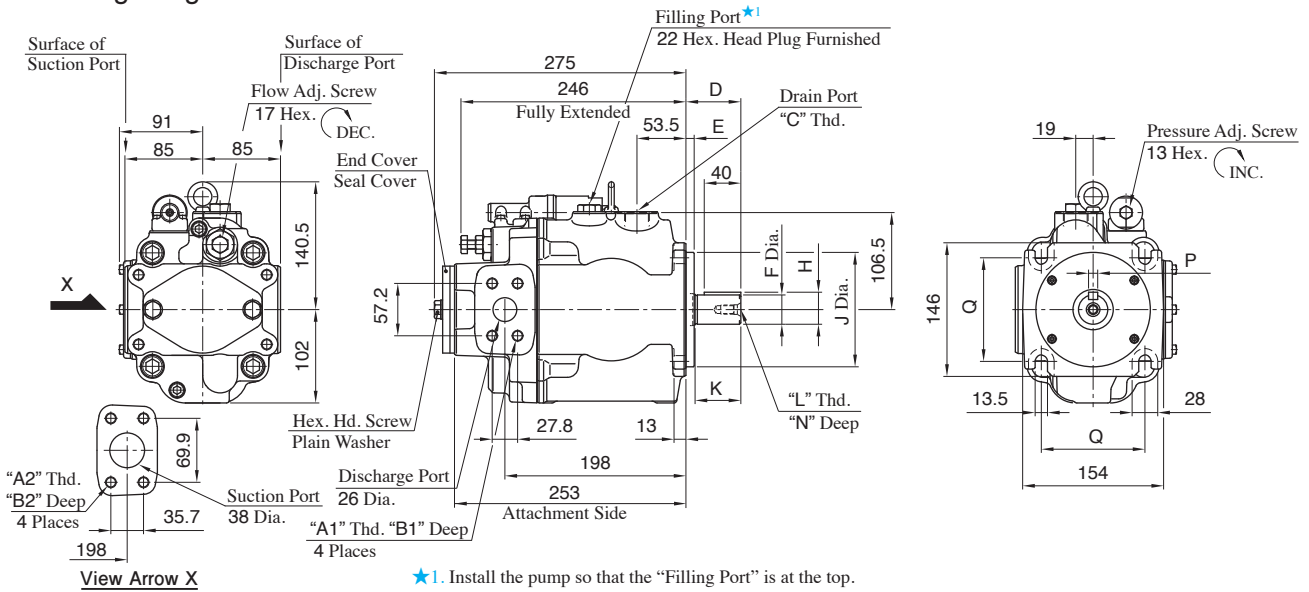

★1. Install the pump so that the "Filling Port" is at the top.

Model Numbers	A1	A2	B1	B2	C	D	E	F	H	J	K	L	N	P	Q	Mounting Flange	Connecting Port	Pipe Flange Threads
A3HG56-FR01KK-E1D/E2D	M12	M12	22	22	M27X2	60	9	32 ^{+0.018} / _{-0.002}	35 ^{+0.018} / _{-0.288}	125 ⁰ / _{-0.063}	50	M10	22	10 ⁰ / _{-0.036}	113.2	Conforms to ISO 3019-2	Metric	Metric
A3HG56-FR01KK-U1D	7/16-14 UNC	1/2-13 UNC	20	21	G 3/4	56	12.7	31.75 ⁰ / _{-0.05}	35.32 ⁰ / _{-0.18}	127 ⁰ / _{-0.05}	48	5/16-18 UNC	19	7.94 ^{+0.03} / ₀	114.5	Conforms to ISO 3019-1	Unified	Unified
A3HG56-FR01KK-U2D	M12	M12	22	22	G 3/4	56	12.7	31.75 ⁰ / _{-0.05}	35.32 ⁰ / _{-0.18}	127 ⁰ / _{-0.05}	48		19	7.94 ^{+0.03} / ₀	114.5	Conforms to ISO 3019-1	BSPP	Metric
A3HG56-FR01KK-J1D	M12	M12	22	22	G 3/4	56	12.7	31.75 ⁰ / _{-0.05}	35.32 ⁰ / _{-0.18}	127 ⁰ / _{-0.05}	48		19	7.94 ^{+0.03} / ₀	114.5	Conforms to ISO 3019-1	Rc	Metric

Drain Port

For port/flange code "U1/J1", adapter and bonded seal are attached. After installing the bonded seal at the drain port tighten the adapter.

● Detail: A3HG56-FR01KK-E1D/E2D

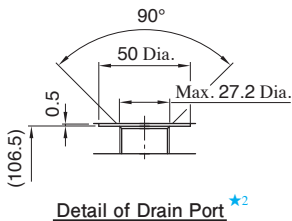

Detail of Drain Port ★2

★2. Drain port conforms to ISO 9974-1, metric threads.

● Accessories: A3HG56-FR01KK-U1D

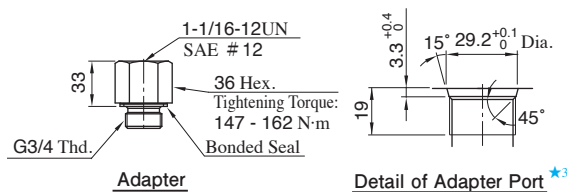

★3. Adapter port conforms to SAE J 514, O-ring seals.

● Detail: A3HG56-FR01KK-U2D

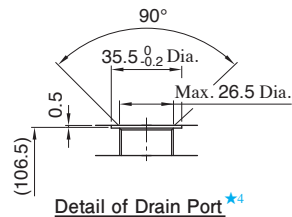

Detail of Drain Port ★4

★4. Drain port conforms to ISO 1179-1, BSPP threads.

● Accessories: A3HG56-FR01KK-J1D

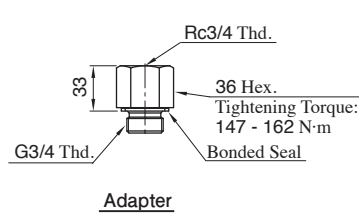

Foot Mtg. Four Bolts: A3HG56-LR01KK-E1D/E2D/U1D/U2D/J1D

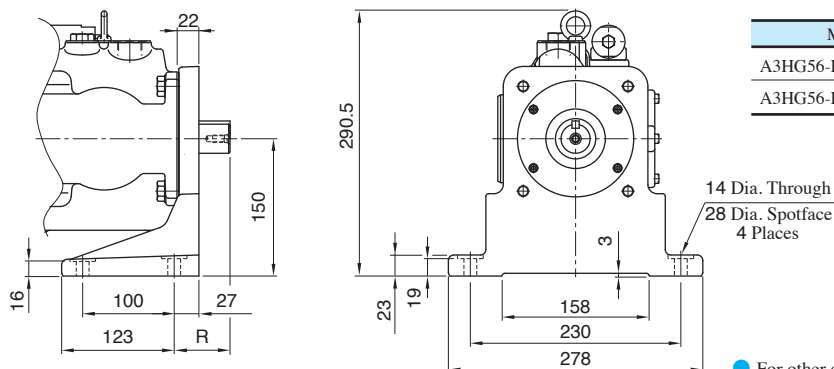

Model Numbers	R
A3HG56-LR01KK-E1D/E2D	65
A3HG56-LR01KK-U1D/U2D/J1D	61

● For other dimensions, refer to "Flange Mtg. Four Bolts".

Flange Mtg.: A3HG71-FR01KK-E1D/E2D/U1D/U2D/J1D

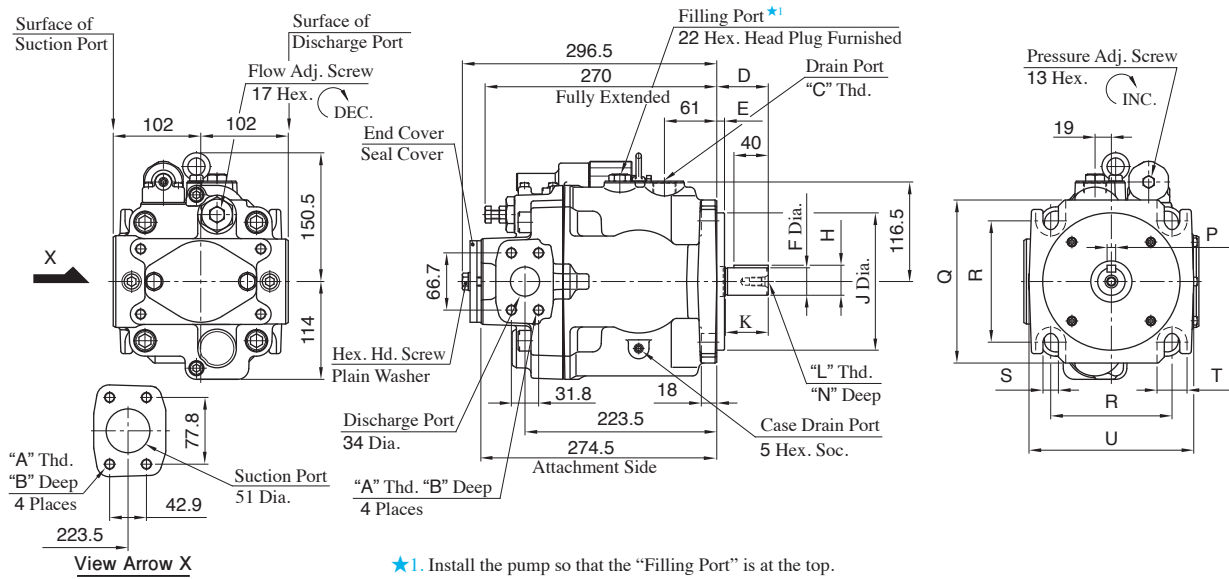

Model Numbers	A	B	C	D	E	F	H	J	K	L	N	P	Q	R	S	T	U	Mounting Flange	Connecting Port	Pipe Flange Threads
A3HG71-FR01KK-E1D/E2D	M12	22	M27X2	60	9	32 ^{+0.018} _{+0.002}	35 ^{+0.018} _{-0.288}	160 ⁰ _{-0.063}	50	M10	22	10 ⁰ _{-0.036}	190	141.4	18	35	192	Conforms to ISO 3019-2	Metric	Metric
A3HG71-FR01KK-U1D	1/2-13 UNC	21	G 3/4	56	12.7	31.75 ⁰ _{-0.05}	35.32 ⁰ _{-0.18}	127 ⁰ _{-0.05}	48		19	7.94 ^{+0.03} ₀	143	114.5	13.5	28	155	Conforms to ISO 3019-1	Unified	Unified
A3HG71-FR01KK-U2D	M12	22	G 3/4	56	12.7	31.75 ⁰ _{-0.05}	35.32 ⁰ _{-0.18}	127 ⁰ _{-0.05}	48	5/16-18 UNC	19	7.94 ^{+0.03} ₀	143	114.5	13.5	28	155	Conforms to ISO 3019-1	BSPP	Metric
A3HG71-FR01KK-J1D	M12	22	G 3/4	56	12.7	31.75 ⁰ _{-0.05}	35.32 ⁰ _{-0.18}	127 ⁰ _{-0.05}	48		19	7.94 ^{+0.03} ₀	143	114.5	13.5	28	155	Conforms to ISO 3019-1	Rc	Metric

Drain Port

For port/flange code "U1/J1", adapter and bonded seal are attached. After installing the bonded seal at the drain port tighten the adapter.

Detail: A3HG71-FR01KK-E1D/E2D

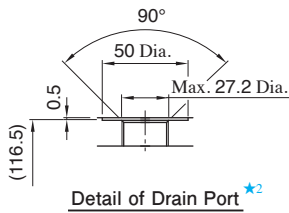

*2. Drain port conforms to ISO 9974-1, metric threads.

Accessories: A3HG71-FR01KK-U1D

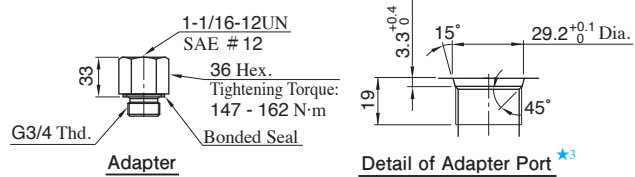

*3. Adapter port conforms to SAE J 514, O-ring seals.

Detail: A3HG71-FR01KK-U2D

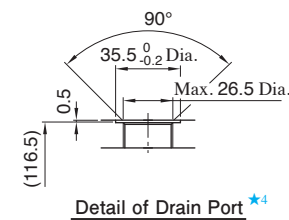

*4. Drain port conforms to ISO 1179-1, BSPP threads.

Accessories: A3HG71-FR01KK-J1D

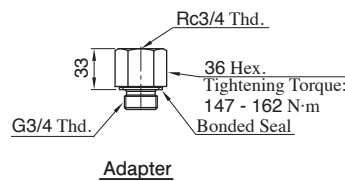

Foot Mtg.: A3HG71-LR01KK-E1D/E2D/U1D/U2D/J1D

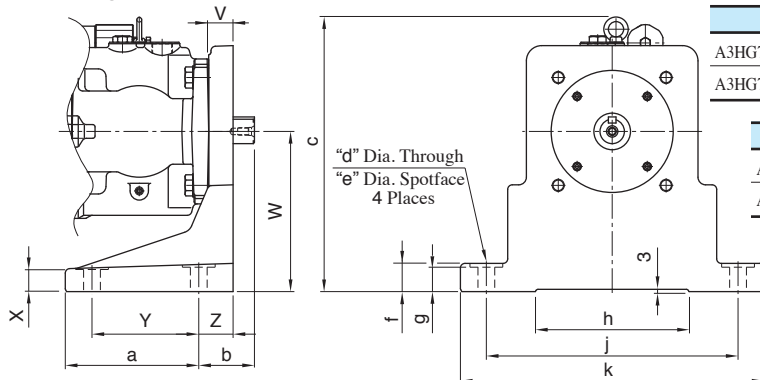

Model Numbers	V	W	X	Y	Z	a	b	c
A3HG71-LR01KK-E1D/E2D	32	210	29	140	45	175	73	360.5
A3HG71-LR01KK-U1D/U2D/J1D	22	150	16	100	27	123	61	300.5

Model Numbers	d	e	f	g	h	j	k
A3HG71-LR01KK-E1D/E2D	22	43	37	32	198	330	398
A3HG71-LR01KK-U1D/U2D/J1D	14	28	23	19	158	230	278

* For other dimensions, refer to "Flange Mtg.".

Flange Mtg.:A3HG100-FR01KK-E1D/E2D/U1D/U2D/J1D

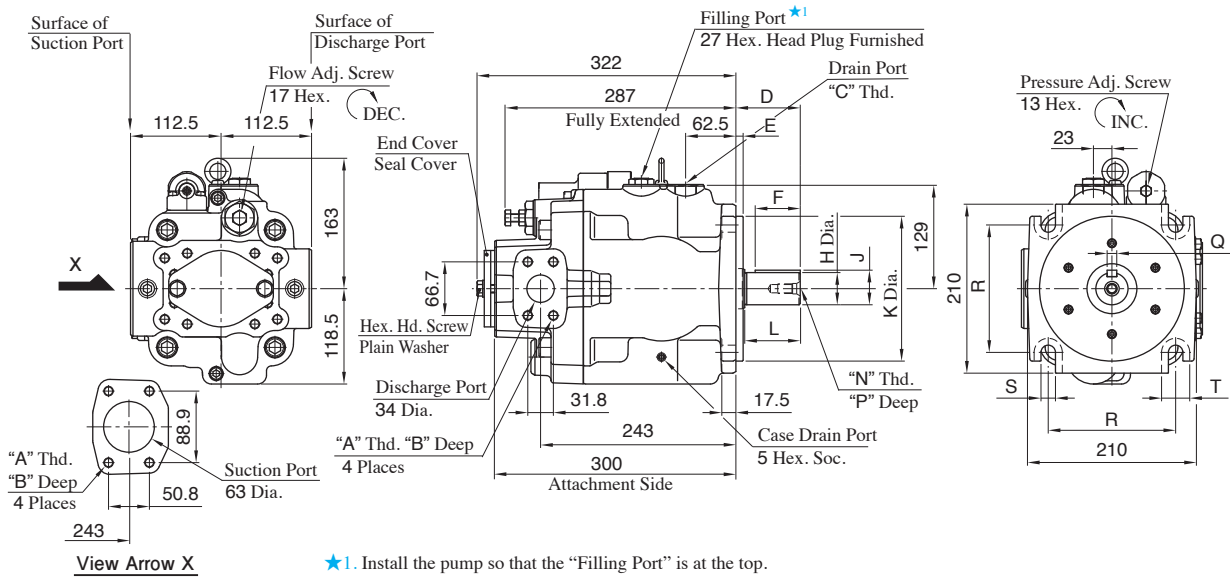

$\star 1$. Install the pump so that the "Filling Port" is at the top.

Model Numbers	A	B	C	D	E	F	H	J	K	L	N	P	Q	R	S	T	Mounting Flange	Connecting Port	Pipe Flange Threads
A3HG100-FR01KK-E1D/E2D	M12	22	M27X2	80	9	56	40 ^{+0.018} / _{+0.002}	43 ^{+0.018} / _{-0.288}	180 ⁰ / _{-0.063}	70	M12	28	12 ⁰ / _{-0.043}	158.4	18	35	Conforms to ISO 3019-2	Metric	Metric
A3HG100-FR01KK-U1D	1/2-13 UNC	21	G 3/4	62	12.7	45	38.1 ⁰ / _{-0.05}	42.36 ⁰ / _{-0.18}	152.4 ⁰ / _{-0.05}	54		28	9.53 ^{+0.03} / ₀	161.6	21.5	39	Conforms to ISO 3019-1	Unified	Unified
A3HG100-FR01KK-U2D	M12	22	G 3/4	62	12.7	45	38.1 ⁰ / _{-0.05}	42.36 ⁰ / _{-0.18}	152.4 ⁰ / _{-0.05}	54	7/16-14 UNC	28	9.53 ^{+0.03} / ₀	161.6	21.5	39	Conforms to ISO 3019-1	BSPP	Metric
A3HG100-FR01KK-J1D	M12	22	G 3/4	62	12.7	45	38.1 ⁰ / _{-0.05}	42.36 ⁰ / _{-0.18}	152.4 ⁰ / _{-0.05}	54		28	9.53 ^{+0.03} / ₀	161.6	21.5	39	Conforms to ISO 3019-1	Rc	Metric

Drain Port

For port/flange code "U1/J1", adapter and bonded seal are attached. After installing the bonded seal at the drain port tighten the adapter.

Detail:A3HG100-FR01KK-E1D/E2D

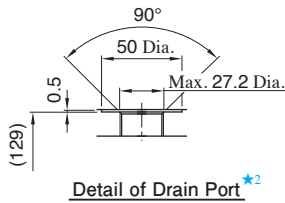

$\star 2$. Drain port conforms to ISO 9974-1, metric threads.

Accessories:A3HG100-FR01KK-U1D

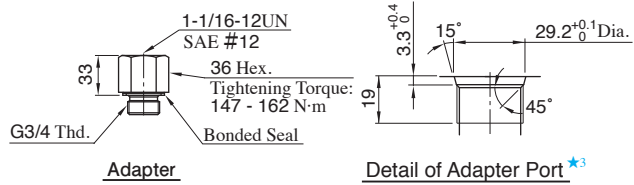

$\star 3$. Adapter port conforms to SAE J 514, O-ring seals.

Detail:A3HG100-FR01KK-U2D

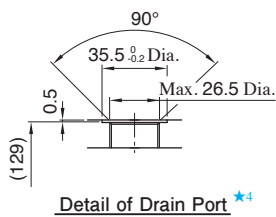

$\star 4$. Drain port conforms to ISO 1179-1, BSPP threads.

Accessories:A3HG100-FR01KK-J1D

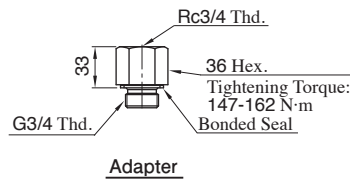

Foot Mtg.:A3HG100-LR01KK-E1D/E2D/U1D/U2D/J1D

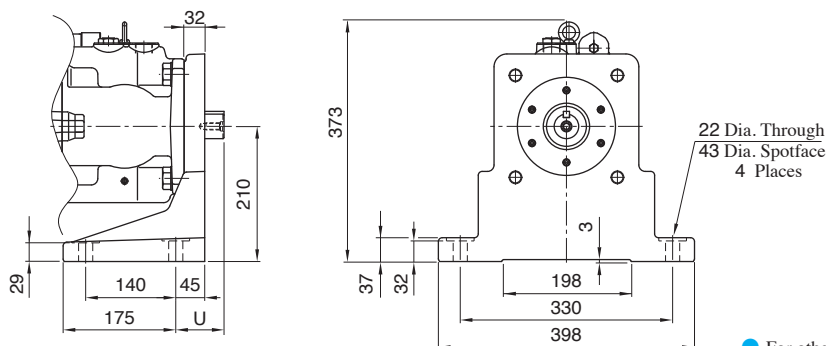

Model Numbers	U
A3HG100-LR01KK-E1D/E2D	93
A3HG100-LR01KK-U1D/U2D/J1D	75

For other dimensions, refer to "Flange Mtg."

Flange Mtg.: A3HG145-FR01KK-E1D/E2D/U1D/U2D/J1D

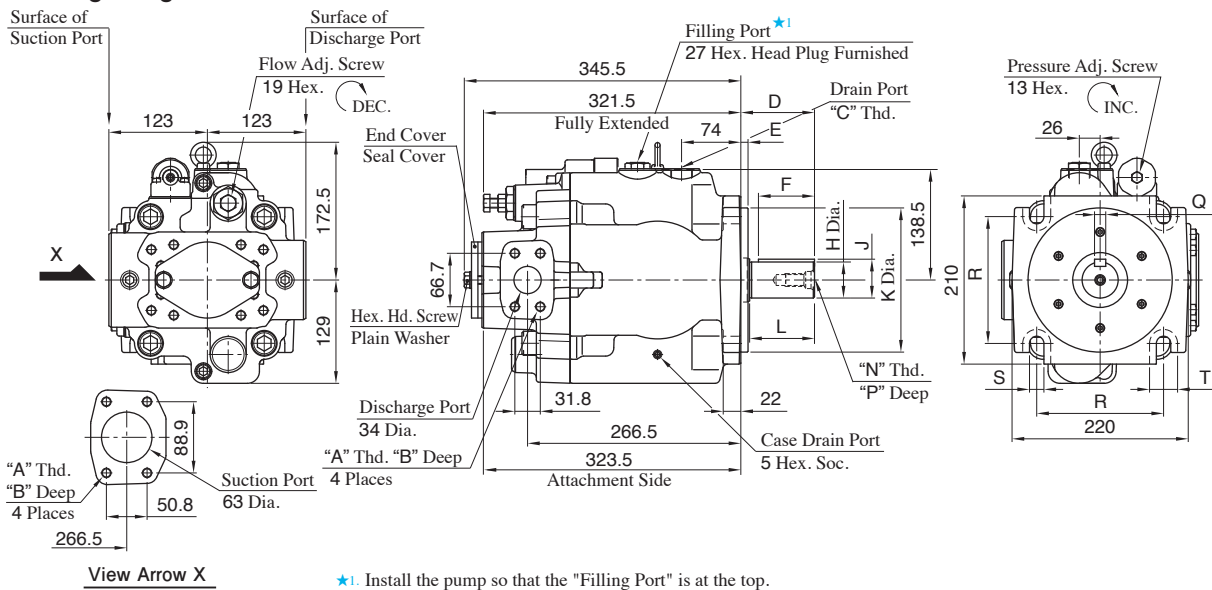

Model Numbers	A	B	C	D	E	F	H	J	K	L	N	P	Q	R	S	T	Mounting Flange	Connecting Port	Pipe Flange Threads
A3HG145-FR01KK-E1D/E2D	M12	22	M27X2	92	9	70	45 ^{+0.018} _{+0.002}	48.5 ^{+0.018} _{-0.288}	180 ⁰ _{-0.063}	82	M16	36	14 ⁰ _{-0.043}	158.4	18	35	Conforms to ISO 3019-2	Metric	Metric
A3HG145-FR01KK-U1D	1/2-13 UNC	21	G 3/4	75	12.7	56	44.45 ⁰ _{-0.05}	49.39 ⁰ _{-0.18}	152.4 ⁰ _{-0.05}	67		32	11.11 ^{+0.03} ₀	161.6	21.5	39	Conforms to ISO 3019-1	Unified	Unified
A3HG145-FR01KK-U2D	M12	22	G 3/4	75	12.7	56	44.45 ⁰ _{-0.05}	49.39 ⁰ _{-0.18}	152.4 ⁰ _{-0.05}	67	1/2-13 UNC	32	11.11 ^{+0.03} ₀	161.6	21.5	39	Conforms to ISO 3019-1	BSPP	Metric
A3HG145-FR01KK-J1D	M12	22	G 3/4	75	12.7	56	44.45 ⁰ _{-0.05}	49.39 ⁰ _{-0.18}	152.4 ⁰ _{-0.05}	67		32	11.11 ^{+0.03} ₀	161.6	21.5	39	Conforms to ISO 3019-1	Rc	Metric

Drain Port

For port/flange code "U1/J1", adapter and bonded seal are attached. After installing the bonded seal at the drain port tighten the adapter.

Detail: A3HG145-FR01KK-E1D/E2D

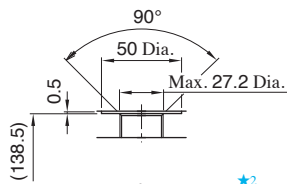

*2. Drain port conforms to ISO 9974-1, metric threads.

Accessories: A3HG145-FR01KK-U1D

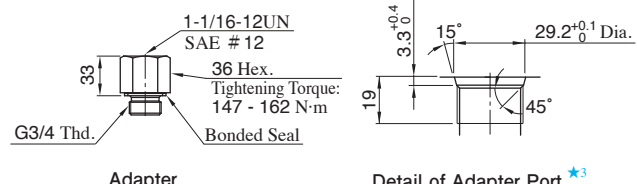

*3. Adapter port conforms to SAE J 514, O-ring seals.

Detail: A3HG145-FR01KK-U2D

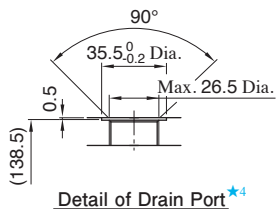

*4. Drain port conforms to ISO 1179-1, BSPP threads.

Accessories: A3HG145-FR01KK-J1D

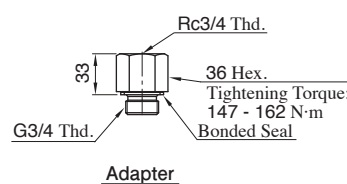

Foot Mtg.: A3HG145-LR01KK-E1D/E2D/U1D/U2D/J1D

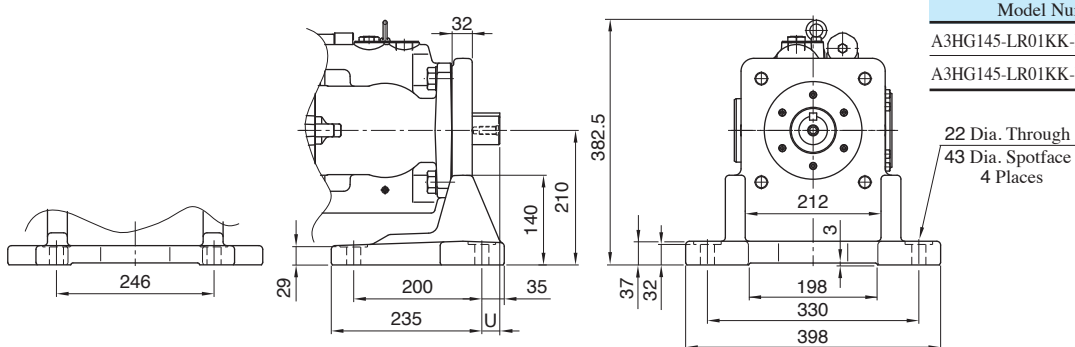

For other dimensions, refer to "Flange Mtg."

Model Numbers	U
A3HG145-LR01KK-E1D/E2D	45
A3HG145-LR01KK-U1D/U2D/J1D	28

Flange Mtg.:A3HG180-FR01KK-E1D/E2D/U1D/U2D/J1D

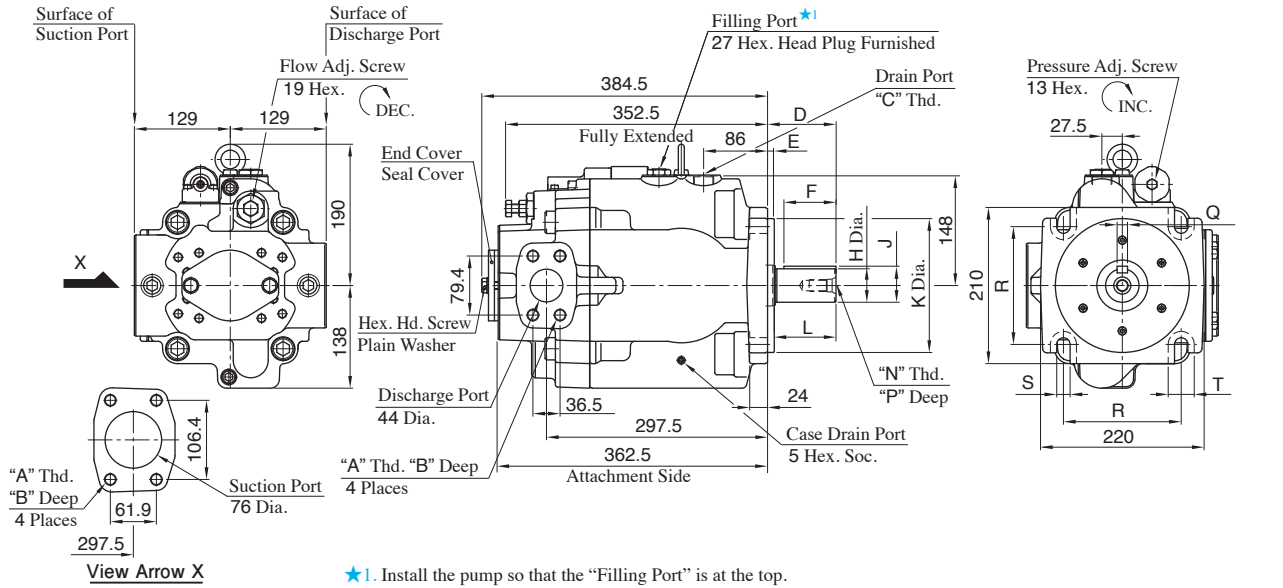

★1. Install the pump so that the "Filling Port" is at the top.

Model Numbers	A	B	C	D	E	F	H	J	K	L	N	P	Q	R	S	T	Mounting Flange	Connecting Port	Pipe Flange Threads
A3HG180-FR01KK-E1D/E2D	M16	29	M27X2	92	9	70	45 ^{+0.018} / _{+0.002}	48.5 ^{+0.018} / _{-0.288}	180 ⁰ / _{-0.063}	82	M16	36	14 ⁰ / _{-0.043}	158.4	18	35	Conforms to ISO 3019-2	Metric	Metric
A3HG180-FR01KK-U1D	5/8-11 UNC	29	G 3/4	75	12.7	56	44.45 ⁰ / _{-0.005}	49.39 ⁰ / _{-0.18}	152.4 ⁰ / _{-0.05}	67		32	11.11 ^{+0.03} / ₀	161.6	21.5	39	Conforms to ISO 3019-1	Unified	Unified
A3HG180-FR01KK-U2D	M16	29	G 3/4	75	12.7	56	44.45 ⁰ / _{-0.005}	49.39 ⁰ / _{-0.18}	152.4 ⁰ / _{-0.05}	67	1/2-13 UNC	32	11.11 ^{+0.03} / ₀	161.6	21.5	39	Conforms to ISO 3019-1	BSP	Metric
A3HG180-FR01KK-J1D	M16	29	G 3/4	75	12.7	56	44.45 ⁰ / _{-0.005}	49.39 ⁰ / _{-0.18}	152.4 ⁰ / _{-0.05}	67		32	11.11 ^{+0.03} / ₀	161.6	21.5	39	Conforms to ISO 3019-1	Rc	Metric

Drain Port

For port/flange code "U1/J1", adapter and bonded seal are attached. After installing the bonded seal at the drain port tighten the adapter.

● Detail:A3HG180-FR01KK-E1D/E2D

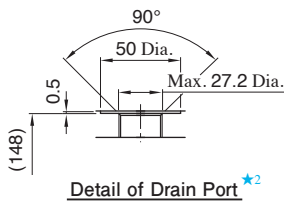

★2. Drain port conforms to ISO 9974-1, metric threads.

● Accessories:A3HG180-FR01KK-U1D

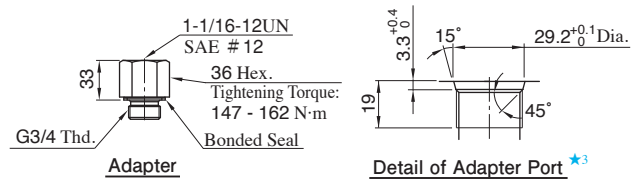

★3. Adapter port conforms to SAE J 514, O-ring seals.

● Detail:A3HG180-FR01KK-U2D

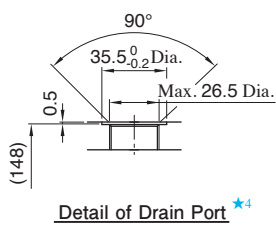

★4. Drain port conforms to ISO 1179-1, BSP threads.

● Accessories:A3HG180-FR01KK-J1D

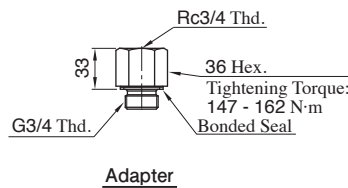

Foot Mtg.:A3HG180-LR01KK-E1D/E2D/U1D/U2D/J1D

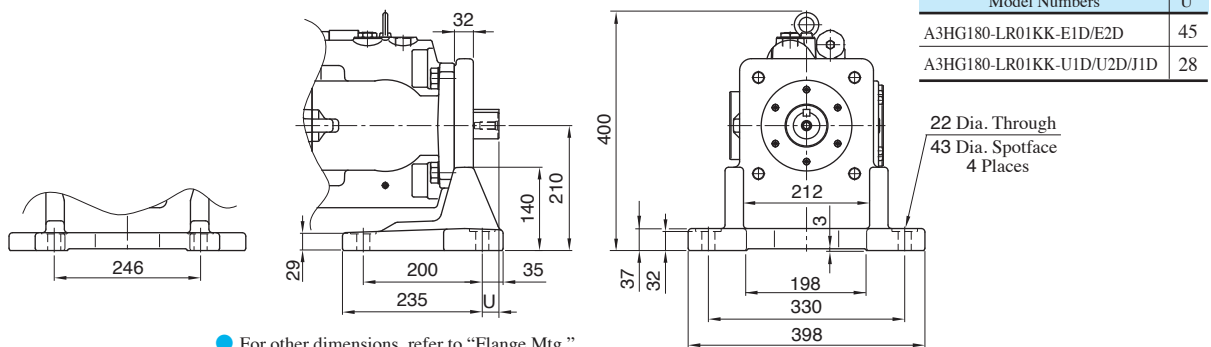

● For other dimensions, refer to "Flange Mtg."

Spare Parts List

A3HG *- *R01KK

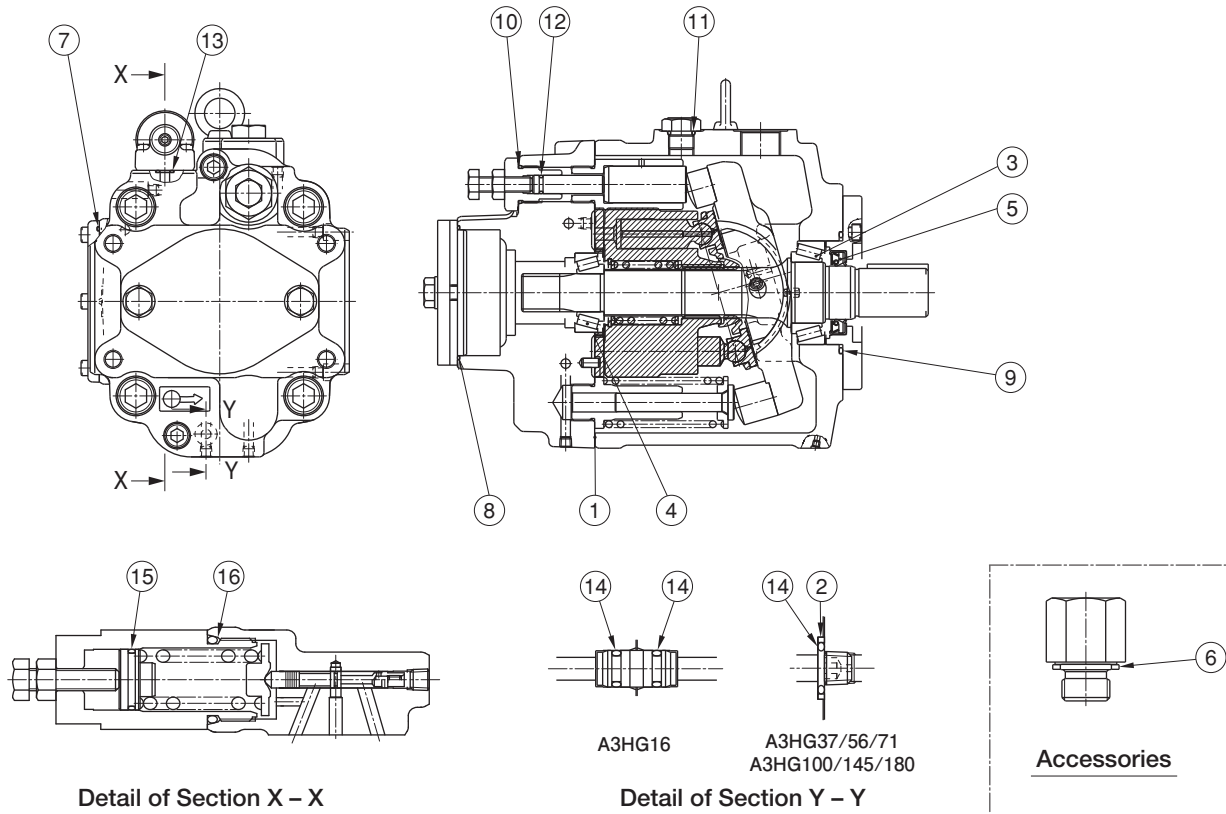

List of Seals and Bearings

Item	Name of Parts	Part Numbers							Qty.	
		A3HG16	A3HG37	A3HG56	A3HG71	A3HG100	A3HG145	A3HG180		
1	Gasket	Z150-2270-PK314095-1	Z800-2271-PK314517-4	Z800-2272-PK314506-7	2283-PK212657-1	2284-PK212655-5	2285-PK212635-7	2286-PK212656-3	1	
2	Back Up Ring	—	1310E-PK412440-0							1
3	Tapered Roller Bearing	—	HR33007J	4T-33008	33009JR	4T-30210	HR33011	—	1	
	Cylindrical Roller Bearing	NUP205E	—	—	—	—	—	2276-PK412859-1		
4	Tapered Roller Bearing	—	4T-33005	4T-33205R	4T-33205	4T-33206	4T-33206	—	1	
	Needle Roller Bearing	HMK2030V3	—	—	—	—	—	2276-PK412860-9		
5	Oil Seal	TCN254511 (FKM)	TCN355511 (FKM)	TCN355511 (FKM)	TCN355511 (FKM)	TCN507212 (FKM)	TCN557812 (FKM)	TCN557812 (FKM)	1	
6	Bonded Seal*	KP-C-04 (FKM)	KP-C-04 (FKM)	KP-C-05 (FKM)	KP-C-05 (FKM)	KP-C-05 (FKM)	KP-C-05 (FKM)	KP-C-05 (FKM)	1	
7	O-Ring	S65 (FKM-70)	S85 (FKM-70)	S95 (FKM-70)	S100 (FKM-70)	S110 (FKM-70)	S125 (FKM-70)	S130 (FKM-70)	1	
8	O-Ring, Gasket	2280-PK413358-3	S80 (FKM-70)	S80 (FKM-70)	S80 (FKM-70)	S80 (FKM-70)	S80 (FKM-70)	S80 (FKM-70)	1	
9	O-Ring	AS568-139 (FKM-90)	OR FKM-70 G70-N	OR FKM-70 G75-N	OR FKM-70 G80-N	OR FKM-70 G95-N	OR FKM-70 G95-N	OR FKM-70 G105-N	1	
10	O-Ring	OR FKM-90 P14-N	OR FKM-90 P18-N	OR FKM-90 P21-N	OR FKM-90 P24-N	OR FKM-90 P24-N	OR FKM-90 P26-N	OR FKM-90 P26-N	1	
11	O-Ring	OR FKM-90 P14-N	OR FKM-90 P14-N	OR FKM-90 P14-N	OR FKM-90 P14-N	OR FKM-90 P18-N	OR FKM-90 P18-N	OR FKM-90 P18-N	1	
12	O-Ring	OR FKM-90 P6-N	OR FKM-90 P8-N	OR FKM-90 P9-N	OR FKM-90 P9-N	OR FKM-90 P9-N	OR FKM-90 P10A-N	OR FKM-90 P10A-N	1	
13	O-Ring	OR FKM-90 P9-N	OR FKM-90 P9-N	OR FKM-90 P9-N	OR FKM-90 P9-N	OR FKM-90 P9-N	OR FKM-90 P9-N	OR FKM-90 P9-N	3	
14	O-Ring	OR FKM-90 P7-N	OR FKM-90 P9-N	OR FKM-90 P9-N	OR FKM-90 P9-N	OR FKM-90 P9-N	OR FKM-90 P9-N	OR FKM-90 P9-N	P7-N:2 P9-N:1	
15	O-Ring	AS568-018 (FKM-70)	AS568-018 (FKM-70)	AS568-018 (FKM-70)	AS568-021 (FKM-70)	AS568-021 (FKM-70)	AS568-021 (FKM-70)	AS568-021 (FKM-70)	1	
16	O-Ring	OR FKM-90 P26-N	OR FKM-90 P26-N	OR FKM-90 P26-N	OR FKM-90 P32-N	OR FKM-90 P32-N	OR FKM-90 P32-N	OR FKM-90 P32-N	1	

* Attached only to the port/flange U1 or J1.

A3HG Series High Pressure Variable Displacement Piston Pumps Pilot Pressure Control Type Pressure Compensator

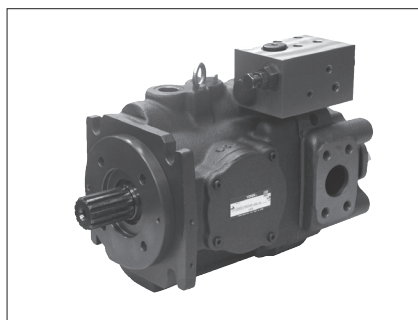

Graphic Symbol

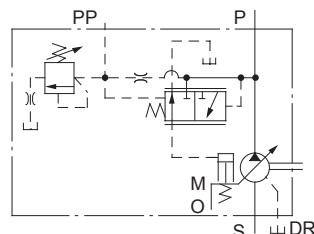

Specifications

Model Numbers	Geometric Displacement cm ³ /rev	Minimum Adjustment Flow cm ³ /rev	Operating Pressure MPa		Minimum Adjustment Pressure MPa	Shaft Speed Range r/min		Approx. Mass kg	
			Rated ^{*1}	Intermittent		Max. ^{*2}	Min.	Flange Mtg.	Foot Mtg.
A3HG16- *R07* - *C-10	16.3	8	31.5	35	5	3600	600	18.9	22.9
A3HG37- *R07* - *C-10	37.1	16				2700	600	28.5	37
A3HG37- *R07* - *D-10								36	
A3HG56- *R07* - *C-10	56.3	35				2500	600	36.5	45
A3HG56- *R07* - *D-10								34.5	42
A3HG71- *R07* -E1D/E2D-10	70.7	45				2300	600	47	73
A3HG71- *R07* -U1D/U2D/J1D-10							43.5	51	
A3HG100- *R07K-E1D/E2D-10	100.5	63			2100	600	58.5	83.5	
A3HG100- *R07SP* -E1D/E2D-10							58	83	
A3HG100- *R07* -U1D/U2D/J1D-10							58	85	
A3HG145- *R07K-E1D/E2D-10							70.5	96.5	
A3HG145- *R07SP* -E1D/E2D-10	145.2	95			1800	600	70	96	
A3HG145- *R07* -U1D/U2D/J1D-10							70	97.5	
A3HG180- *R07K-E1D/E2D-10							90	116	
A3HG180- *R07SP* -E1D/E2D-10	180.7	130			1800	600	89.5	115.5	
A3HG180- *R07* -U1D/U2D/J1D-10							89.5	117	

★1. Consult Yuken when pump is used over rated pressure because there is a restriction on operating condition.

★2. The maximum shaft speeds shown in the above table are at suction pressure 0 kPa.

Model Number Designation

A3HG16	-F	R	07	K	-E1					D	-10										
Series Number	Mounting	Direction of Rotation	Control Type	Shaft Extension	Main Pump Mtg. Flange Connecting Port / Pipe Flange Thread Second Pump Mtg.					Number of Pump Mtg. Bolts	Design Number										
A3HG16 (16.3 cm ³ /rev)	F: Flange Mtg. L: Foot Mtg.	(Viewed from Shaft End) R: Clockwise (Normal)	07: Pilot Pressure Control Type Pressure Compensator	K: Keyed Shaft SP: Splined Shaft (High Torque) SP1: Splined Shaft (Conforms to ISO 3019-1)	Code	Main Pump Mtg. Flange	Connecting Port	Pipe Flange Thread	Second Pump Mtg.	C: 2 D: 4	10										
A3HG37 (37.1 cm ³ /rev)																					
A3HG56 (56.3 cm ³ /rev)																					
A3HG71 (70.7 cm ³ /rev)																					
A3HG100 (100.5 cm ³ /rev)																					
A3HG145 (145.2 cm ³ /rev)																					
A3HG180 (180.7 cm ³ /rev)																					

■ Pipe Flange Kits

Pipe flange mouting surface conforms to SAE J 518, 4 bolt split flange.
 Pipe flange kits are not available. Contact us for details.

Typical Performance Characteristics of Type "A3HG71" at Viscosity 32 mm²/s [ISO VG32 Oils, 40°C]

■ Pressure vs. Output Flow

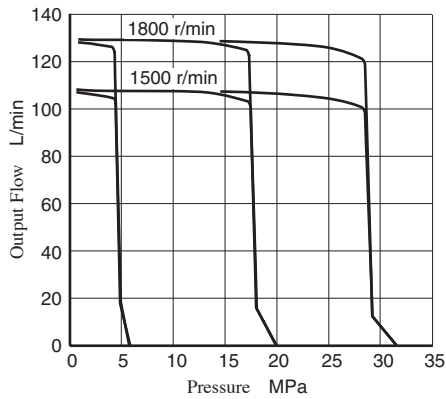

■ Full Cut-off Power

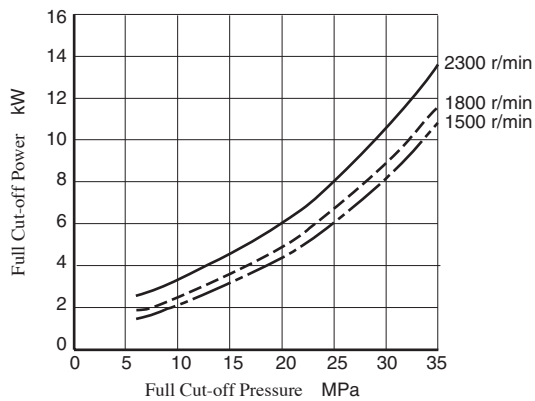

■ Full Cut-off Drain

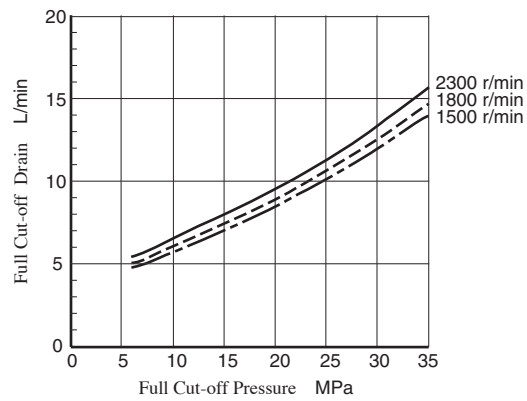

Flange Mtg.:A3HG16-FR07K-E1C/U1C/U2C/J1C

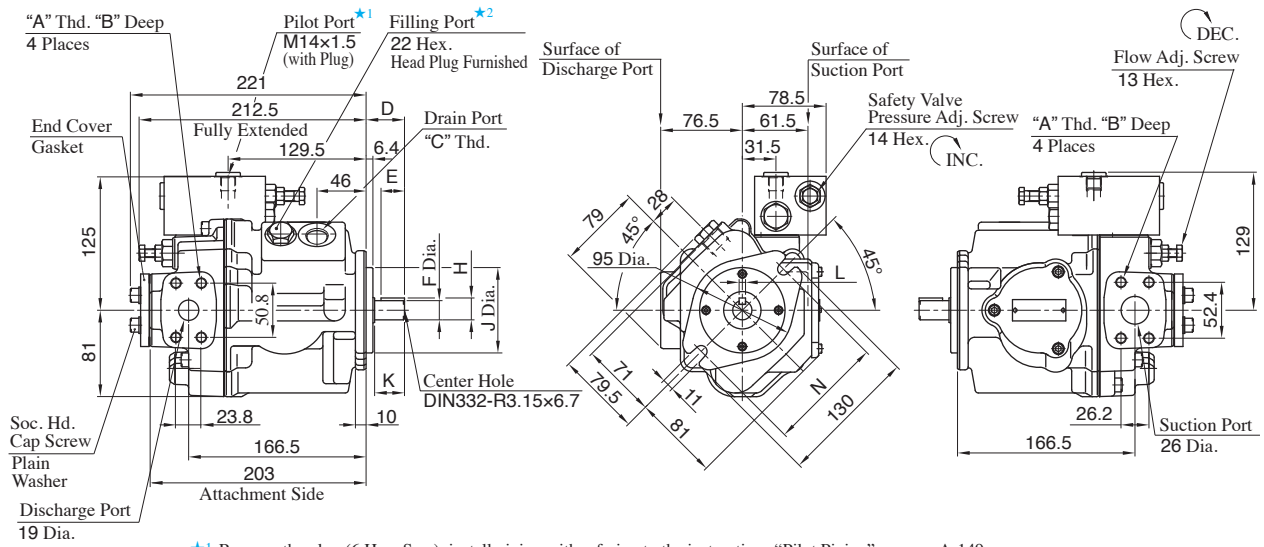

- ★1. Remove the plug (6 Hex. Soc.), install piping with referring to the instructions "Pilot Piping" on page A-149.
- ★2. Install the pump so that the "Filling Port" is at the top.

Model Numbers	A	B	C	D	E	F	H	J	K	L	N	Mounting Flange	Connecting Port	Pipe Flange Threads
A3HG16-FR07K-E1C	M10	19	M22×1.5	36	22	18 ^{+0.008} _{-0.003}	20.5 ^{+0.008} _{-0.133}	80 ⁰ _{-0.046}	28	6 ⁰ _{-0.03}	109	Conforms to ISO 3019-2	Metric	Metric
A3HG16-FR07K-U1C	3/8-16 UNC	17	G 1/2	41	28	19.05 ⁰ _{-0.03}	21.24 ⁰ _{-0.16}	82.55 ⁰ _{-0.05}	33	4.76 ^{+0.03} ₀	106	Conforms to ISO 3019-1	Unified	Unified
A3HG16-FR07K-U2C	M10	19	G 1/2	41	28	19.05 ⁰ _{-0.03}	21.24 ⁰ _{-0.16}	82.55 ⁰ _{-0.05}	33	4.76 ^{+0.03} ₀	106	Conforms to ISO 3019-1	BSP	Metric
A3HG16-FR07K-J1C	M10	19	G 1/2	41	28	19.05 ⁰ _{-0.03}	21.24 ⁰ _{-0.16}	82.55 ⁰ _{-0.05}	33	4.76 ^{+0.03} ₀	106	Conforms to ISO 3019-1	Rc	Metric

Pilot Port

For port/flange code "U1/U2/J1", adapter and O-ring are attached. After installing the O-ring at the drain port tighten the adapter.

● **Detail:A3HG16-FR07K-E1C**

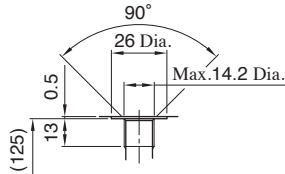

Detail of Pilot Port ★3

★3. Pilot port conforms to ISO 9974-1, metric threads.

● **Accessories:A3HG16-FR07K-U2C**

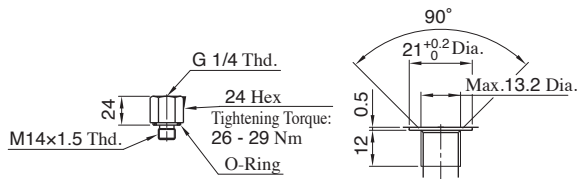

Adapter

Detail of Adapter Port ★5

★5. Adapter port conforms to ISO 1179-1, BSPP threads.

● **Accessories:A3HG16-FR07K-U1C**

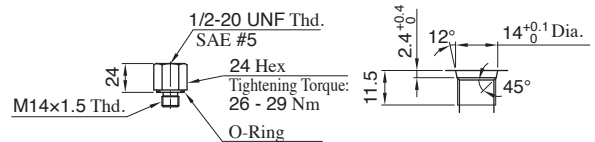

Adapter

Detail of Adapter Port ★4

★4. Adapter port conforms to SAE J 514, O-ring seals

● **Accessories:A3HG16-FR07K-J1C**

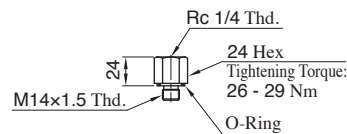

Adapter

Drain Port

Drain port is common to that of pressure compensator model. Refer to page A-162 for the dimensions of drain port.

Foot Mtg.:A3HG16-LR07K-E1C/U1C/U2C/J1C

Mounting bracket is common to that of pressure compensator model (except max. height dimension). Refer to page A-162 for the dimensions of mounting bracket.

Flange Mtg. Two Bolts:A3HG37-FR07K-E1C/E2C/U1C/U2C/J1C

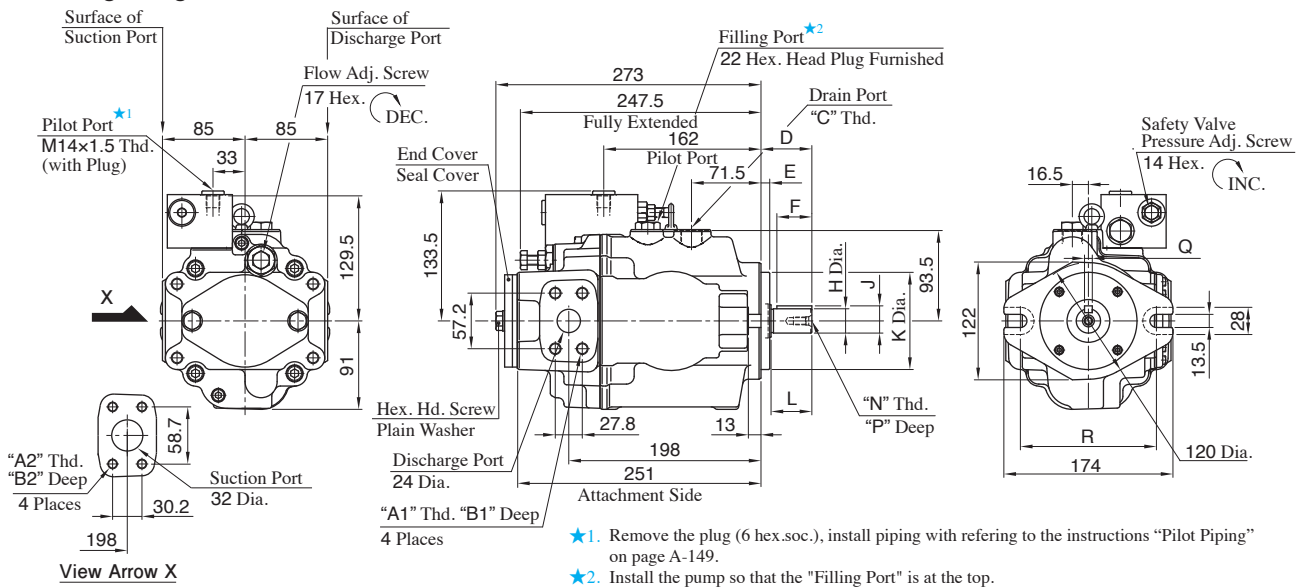

Model Numbers	A1	A2	B1	B2	C	D	E	F	H	J	K	L	N	P	Q	R	Mounting Flange	Connecting Port	Pipe Flange Threads
A3HG37-FR07K-E1C/E2C	M12	M10	22	18	M22X1.5	52	9	36	25 ^{+0.009} _{-0.004}	28 ^{+0.009} _{-0.294}	100 ⁰ _{-0.054}	42	M8	19	8 ⁰ _{-0.036}	140	Conforms to ISO 3019-2	Metric	Metric
A3HG37-FR07K-U1C	7/16-14 UNC		20		G 1/2	46	9.7	32	25.4 ⁰ _{-0.05}	28.18 ⁰ _{-0.18}	101.6 ⁰ _{-0.05}	38	1/4-20 UNC	16	6.35 ^{+0.03} ₀	146	Conforms to ISO 3019-1	Unified	Unified
A3HG37-FR07K-U2C	M12	M10	22	18	G 1/2	46	9.7	32	25.4 ⁰ _{-0.05}	28.18 ⁰ _{-0.18}	101.6 ⁰ _{-0.05}	38	1/4-20 UNC	16	6.35 ^{+0.03} ₀	146	Conforms to ISO 3019-1	BSPP	Metric
A3HG37-FR07K-J1C	M12	M10	22	18	G 1/2	46	9.7	32	25.4 ⁰ _{-0.05}	28.18 ⁰ _{-0.18}	101.6 ⁰ _{-0.05}	38	1/4-20 UNC	16	6.35 ^{+0.03} ₀	146	Conforms to ISO 3019-1	Rc	Metric

Flange Mtg. Four Bolts:A3HG37-FR07K-E1D/E2D/U1D/U2D/J1D

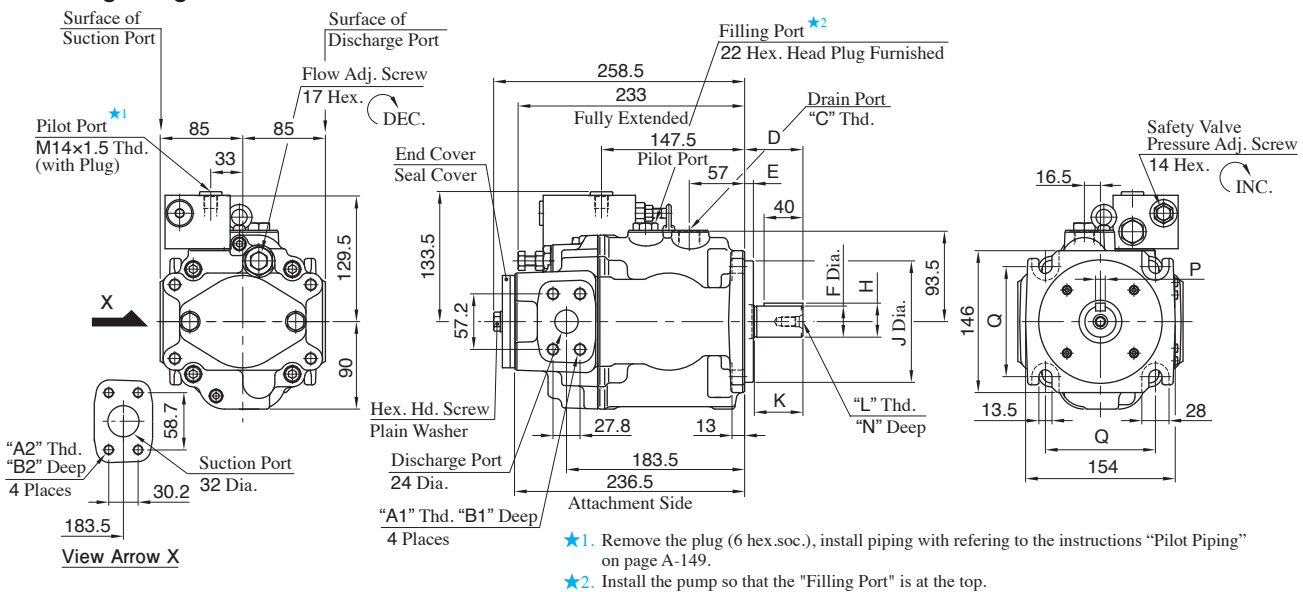

Model Numbers	A1	A2	B1	B2	C	D	E	F	H	J	K	L	N	P	Q	Mounting Flange	Connecting Port	Pipe Flange Threads
A3HG37-FR07K-E1D/E2D	M12	M10	22	18	M22X1.5	60	9	32 ^{+0.018} _{+0.002}	35 ^{+0.018} _{-0.288}	125 ⁰ _{-0.063}	50	M10	22	10 ⁰ _{-0.036}	113.2	Conforms to ISO 3019-2	Metric	Metric
A3HG37-FR07K-U1D	7/16-14 UNC		20		G 1/2	56	12.7	31.75 ⁰ _{-0.05}	35.32 ⁰ _{-0.18}	127 ⁰ _{-0.05}	48	5/16-18 UNC	19	7.94 ^{+0.03} ₀	114.5	Conforms to ISO 3019-1	Unified	Unified
A3HG37-FR07K-U2D	M12	M10	22	18	G 1/2	56	12.7	31.75 ⁰ _{-0.05}	35.32 ⁰ _{-0.18}	127 ⁰ _{-0.05}	48	5/16-18 UNC	19	7.94 ^{+0.03} ₀	114.5	Conforms to ISO 3019-1	BSPP	Metric
A3HG37-FR07K-J1D	M12	M10	22	18	G 1/2	56	12.7	31.75 ⁰ _{-0.05}	35.32 ⁰ _{-0.18}	127 ⁰ _{-0.05}	48	5/16-18 UNC	19	7.94 ^{+0.03} ₀	114.5	Conforms to ISO 3019-1	Rc	Metric

Pilot Port

Pilot port is common to that of "A3HG16-FR07K-E1C/U1C/U2C/J1C" (except the height dimension from the center of the pump). Refer to page A-174 for the dimensions of pilot port.

Drain Port

Drain port is common to that of pressure compensator model. Refer to page A-163 or A-164 for the dimensions of drain port.

Foot Mtg.:A3HG37-LR07K-E1C/E2C/U1C/U2C/J1C, A3HG37-LR07K-E1D/E2D/U1D/U2D/J1D

Mounting bracket is common to that of pressure compensator model (except max. height dimension). Refer to pages A-163 and A-164 for the dimensions of mounting bracket.

Flange Mtg. Two Bolts:A3HG56-FR07K-E1C/E2C/U1C/U2C/J1C

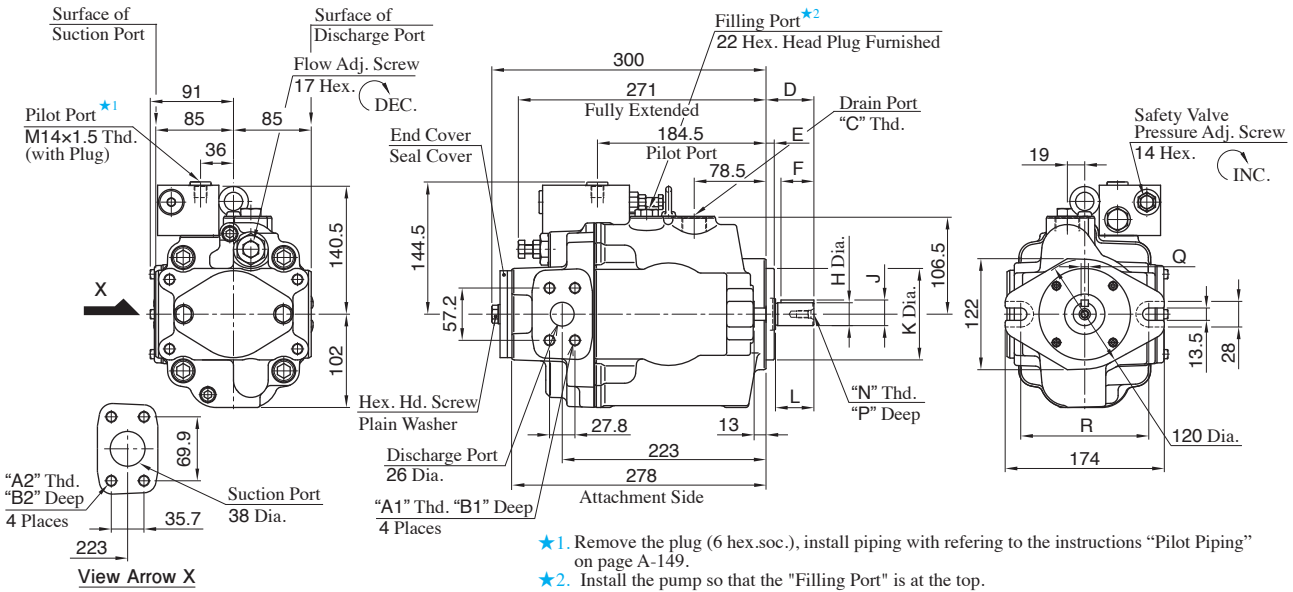

Model Numbers	A1	A2	B1	B2	C	D	E	F	H	J	K	L	N	P	Q	R	Mounting Flange	Connecting Port	Pipe Flange Threads
A3HG56-FR07K-E1C/E2C	M12	M12	22	22	M27 x 2	52	9	36	25 ^{+0.009} _{-0.004}	28 ^{+0.009} _{-0.294}	100 ⁰ _{0.054}	42	M8	19	8 ⁰ _{-0.036}	140	Conforms to ISO 3019-2	Metric	Metric
A3HG56-FR07K-U1C	7/16-14 UNC	1/2-13 UNC	20	21	G 3/4	46	9.7	32	25.4 ⁰ _{-0.05}	28.18 ⁰ _{-0.18}	101.6 ⁰ _{-0.05}	38	1/4-20 UNC	16	6.35 ^{+0.03} ₀	146	Conforms to ISO 3019-1	Unified	Unified
A3HG56-FR07K-U2C	M12	M12	22	22	G 3/4	46	9.7	32	25.4 ⁰ _{-0.05}	28.18 ⁰ _{-0.18}	101.6 ⁰ _{-0.05}	38	1/4-20 UNC	16	6.35 ^{+0.03} ₀	146	Conforms to ISO 3019-1	BSP	Metric
A3HG56-FR07K-J1C	M12	M12	22	22	G 3/4	46	9.7	32	25.4 ⁰ _{-0.05}	28.18 ⁰ _{-0.18}	101.6 ⁰ _{-0.05}	38	16	6.35 ^{+0.03} ₀	146	Conforms to ISO 3019-1	Rc	Metric	

Flange Mtg. Four Bolts:A3HG56-FR07K-E1D/E2D/U1D/U2D/J1D

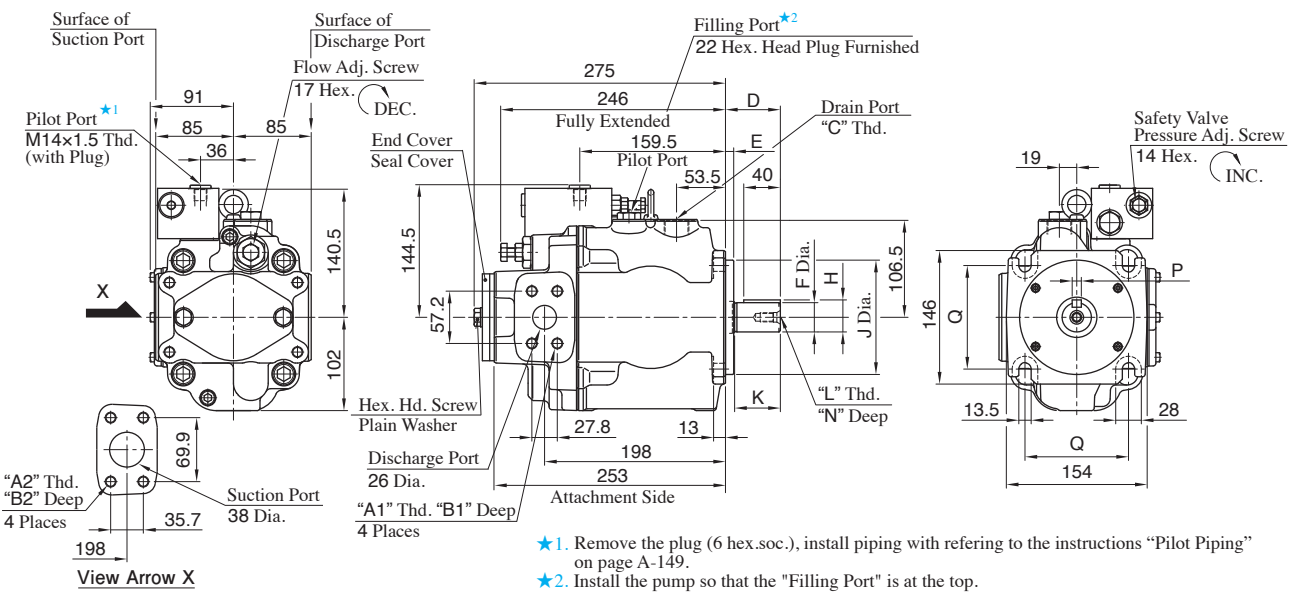

Model Numbers	A1	A2	B1	B2	C	D	E	F	H	J	K	L	N	P	Q	Mounting Flange	Connecting Port	Pipe Flange Threads
A3HG56-FR07K-E1D/E2D	M12	M12	22	22	M27 x 2	60	9	32 ^{+0.018} _{+0.002}	35 ^{+0.018} _{-0.288}	125 ⁰ _{-0.063}	50	M10	22	10 ⁰ _{-0.036}	113.2	Conforms to ISO 3019-2	Metric	Metric
A3HG56-FR07K-U1D	7/16-14 UNC	1/2-13 UNC	20	21	G 3/4	56	12.7	31.75 ⁰ _{-0.05}	35.32 ⁰ _{-0.18}	127 ⁰ _{-0.05}	48	19	7.94 ^{+0.03} ₀	114.5	Conforms to ISO 3019-1	Unified	Unified	
A3HG56-FR07K-U2D	M12	M12	22	22	G 3/4	56	12.7	31.75 ⁰ _{-0.05}	35.32 ⁰ _{-0.18}	127 ⁰ _{-0.05}	48	5/16-18 UNC	19	7.94 ^{+0.03} ₀	114.5	Conforms to ISO 3019-1	BSP	Metric
A3HG56-FR07K-J1D	M12	M12	22	22	G 3/4	56	12.7	31.75 ⁰ _{-0.05}	35.32 ⁰ _{-0.18}	127 ⁰ _{-0.05}	48	19	7.94 ^{+0.03} ₀	114.5	Conforms to ISO 3019-1	Rc	Metric	

Pilot Port

Pilot port is common to that of "A3HG16-FR07K-E1C/U1C/U2C/J1C" (except the height dimension from the center of the pump). Refer to page A-174 for the dimensions of pilot port.

Drain Port

Drain port is common to that of pressure compensator model. Refer to page A-165 or A-166 for the dimensions of drain port.

Foot Mtg.:A3HG56-LR07K-E1C/E2C/U1C/U2C/J1C, A3HG56-LR07K-E1D/E2D/U1D/U2D/J1D

Mounting bracket is common to that of pressure compensator model (except max. height dimension). Refer to pages A-165 and A-166 for the dimensions of mounting bracket.

Flange Mtg.: A3HG71-FR07K-E1D/E2D/U1D/U2D/J1D

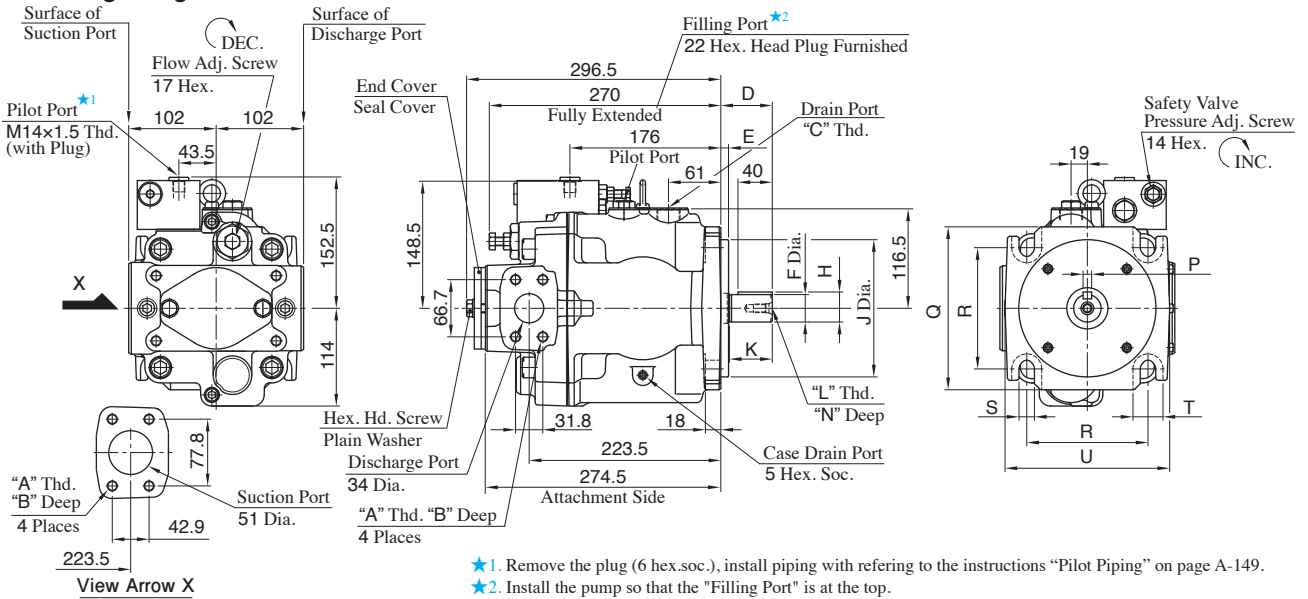

Model Numbers	A	B	C	D	E	F	H	J	K	L	N	P	Q	R	S	T	U	Mounting Flange	Connecting Port	Pipe Flange Threads
A3HG71-FR07K-E1D/E2D	M12	22	M27x2	60	9	32 ^{+0.018} / _{+0.002}	35 ^{+0.018} / _{-0.288}	160 ⁰ / _{-0.063}	50	M10	22	10 ⁰ / _{-0.036}	190	141.4	18	35	192	Conforms to ISO 3019-2	Metric	Metric
A3HG71-FR07K-U1D	1/2-13 UNC	21	G 3/4	56	12.7	31.75 ⁰ / _{-0.05}	35.32 ⁰ / _{-0.18}	127 ⁰ / _{-0.05}	48		19	7.94 ^{+0.03} / ₀	143	114.5	13.5	28	155	Conforms to ISO 3019-1	Unified	Unified
A3HG71-FR07K-U2D	M12	22	G 3/4	56	12.7	31.75 ⁰ / _{-0.05}	35.32 ⁰ / _{-0.18}	127 ⁰ / _{-0.05}	48	5/16-18 UNC	19	7.94 ^{+0.03} / ₀	143	114.5	13.5	28	155	Conforms to ISO 3019-1	BSP	Metric
A3HG71-FR07K-J1D	M12	22	G 3/4	56	12.7	31.75 ⁰ / _{-0.05}	35.32 ⁰ / _{-0.18}	127 ⁰ / _{-0.05}	48		19	7.94 ^{+0.03} / ₀	143	114.5	13.5	28	155	Conforms to ISO 3019-1	Re	Metric

Flange Mtg.: A3HG100-FR07K-E1D/E2D/U1D/U2D/J1D

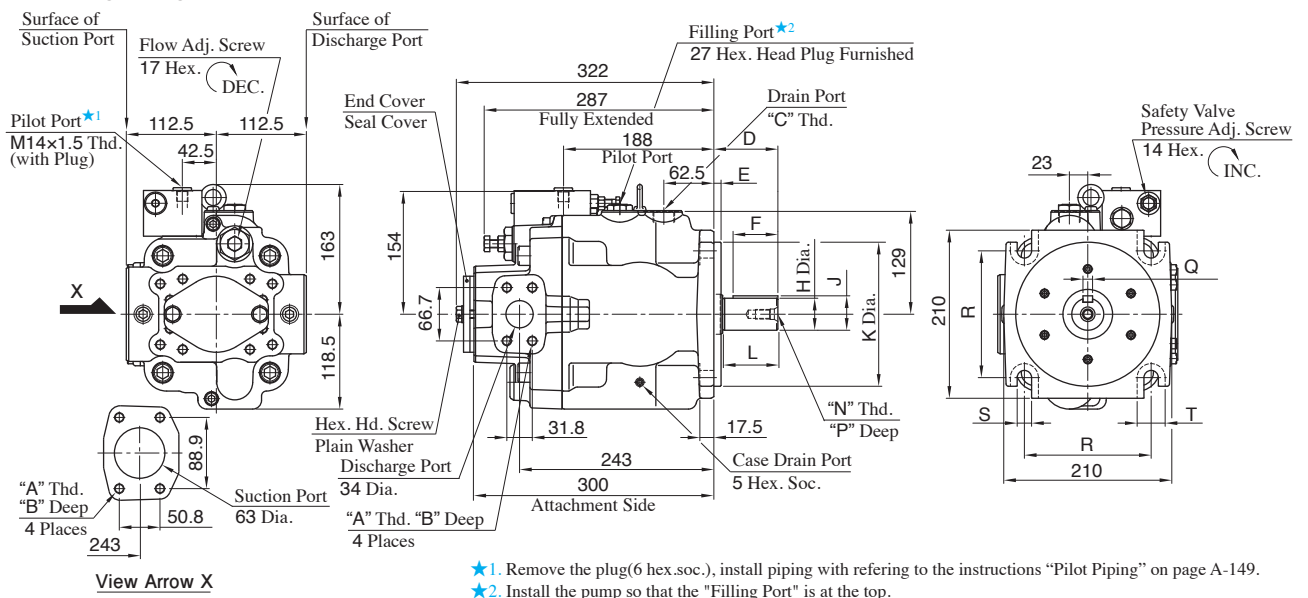

Model Numbers	A	B	C	D	E	F	H	J	K	L	N	P	Q	R	S	T	U	Mounting Flange	Connecting Port	Pipe Flange Threads
A3HG100-FR07K-E1D/E2D	M12	22	M27x2	80	9	40 ^{+0.018} / _{+0.002}	43 ^{+0.018} / _{-0.288}	180 ⁰ / _{-0.063}	70	M12	28	12 ⁰ / _{-0.043}	158.4	18	35			Conforms to ISO 3019-2	Metric	Metric
A3HG100-FR07K-U1D	1/2-13 UNC	21	G 3/4	62	12.7	38.1 ⁰ / _{-0.05}	42.36 ⁰ / _{-0.18}	152.4 ⁰ / _{-0.05}	54		28	9.53 ^{+0.03} / ₀	161.6	21.5	39			Conforms to ISO 3019-1	Unified	Unified
A3HG100-FR07K-U2D	M12	22	G 3/4	62	12.7	38.1 ⁰ / _{-0.05}	42.36 ⁰ / _{-0.18}	152.4 ⁰ / _{-0.05}	54	7/16-14 UNC	28	9.53 ^{+0.03} / ₀	161.6	21.5	39			Conforms to ISO 3019-1	BSP	Metric
A3HG100-FR07K-J1D	M12	22	G 3/4	62	12.7	38.1 ⁰ / _{-0.05}	42.36 ⁰ / _{-0.18}	152.4 ⁰ / _{-0.05}	54		28	9.53 ^{+0.03} / ₀	161.6	21.5	39			Conforms to ISO 3019-1	Re	Metric

Pilot Port

Pilot port is common to that of "A3HG16-FR07K-E1C/U1C/U2C/J1C" (except the height dimension from the center of the pump). Refer to page A-174 for the dimensions of pilot port.

Drain Port

Drain port is common to that of pressure compensator model. Refer to page A-167 or A-168 for the dimensions of drain port.

Foot Mtg.: A3HG71-LR07K-E1D/E2D/U1D/U2D/J1D, A3HG100-LR07K-E1D/E2D/U1D/U2D/J1D

Mounting bracket is common to that of pressure compensator model. Refer to pages A-167 and A-168 for the dimensions of mounting bracket.

Flange Mtg.:A3HG145-FR07K-E1D/E2D/U1D/U2D/J1D

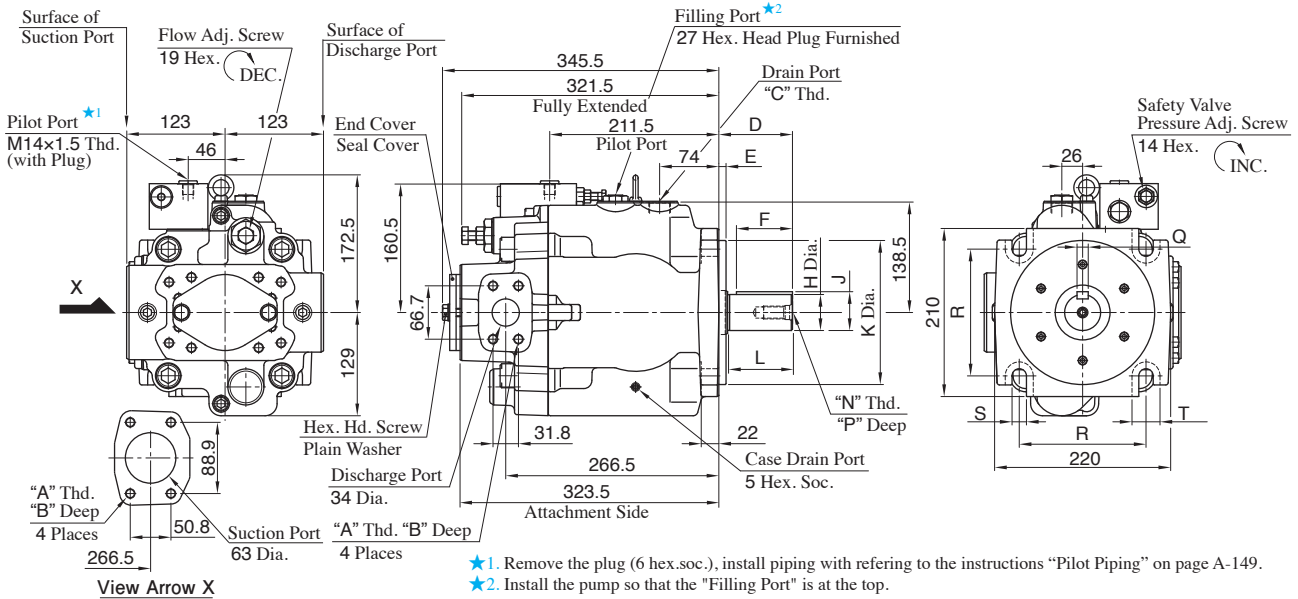

Model Numbers	A	B	C	D	E	F	H	J	K	L	N	P	Q	R	S	T	Mounting Flange	Connecting Port	Pipe Flange Threads
A3HG145-FR07K-E1D/E2D	M12	22	M27X2	92	9	70	45 ^{+0.018} / _{+0.002}	48.5 ^{+0.018} / _{-0.288}	180 ⁰ / _{-0.063}	82	M16	36	14 ⁰ / _{-0.043}	158.4	18	35	Conforms to ISO 3019-2	Metric	Metric
A3HG145-FR07K-U1D	1/2-13 UNC	21	G 3/4	75	12.7	56	44.45 ⁰ / _{-0.05}	49.39 ⁰ / _{-0.18}	152.4 ⁰ / _{-0.05}	67		32	11.11 ^{+0.03} / ₀	161.6	21.5	39	Conforms to ISO 3019-1	Unified	Unified
A3HG145-FR07K-U2D	M12	22	G 3/4	75	12.7	56	44.45 ⁰ / _{-0.05}	49.39 ⁰ / _{-0.18}	152.4 ⁰ / _{-0.05}	67	1/2-13 UNC	32	11.11 ^{+0.03} / ₀	161.6	21.5	39	Conforms to ISO 3019-1	BSPP	Metric
A3HG145-FR07K-J1D	M12	22	G 3/4	75	12.7	56	44.45 ⁰ / _{-0.05}	49.39 ⁰ / _{-0.18}	152.4 ⁰ / _{-0.05}	67		32	11.11 ^{+0.03} / ₀	161.6	21.5	39	Conforms to ISO 3019-1	Rc	Metric

Flange Mtg.:A3HG180-FR07K-E1D/E2D/U1D/U2D/J1D

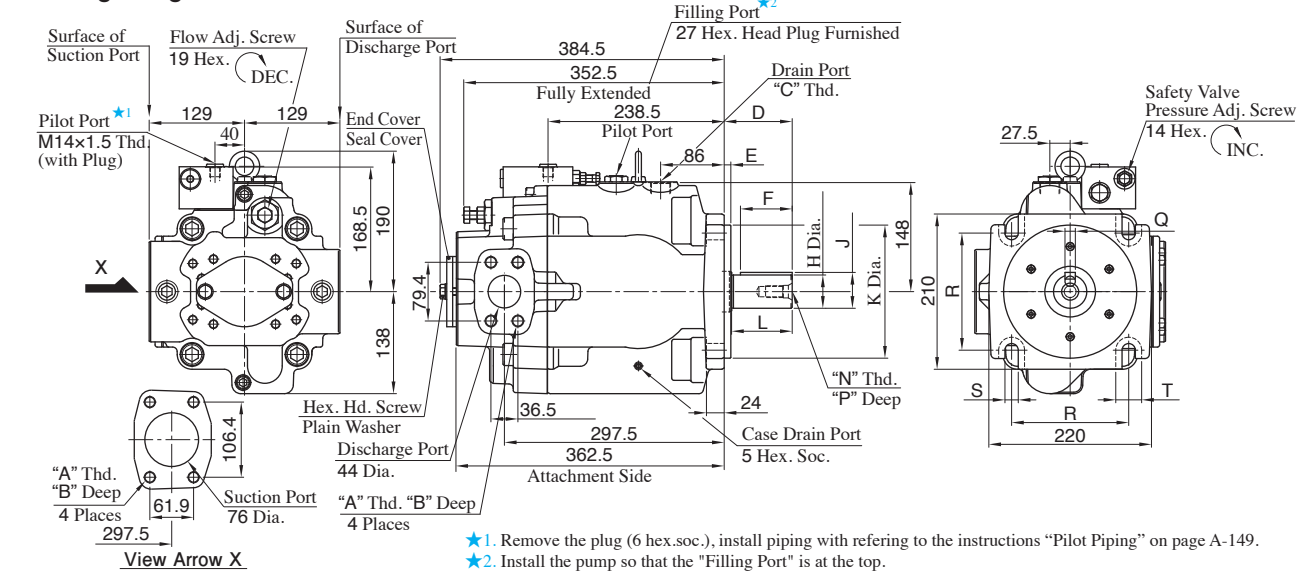

Model Numbers	A	B	C	D	E	F	H	J	K	L	N	P	Q	R	S	T	Mounting Flange	Connecting Port	Pipe Flange Threads
A3HG180-FR07K-E1D/E2D	M16	29	M27X2	92	9	70	45 ^{+0.018} / _{+0.002}	48.5 ^{+0.018} / _{-0.288}	180 ⁰ / _{-0.063}	82	M16	36	14 ⁰ / _{-0.043}	158.4	18	35	Conforms to ISO 3019-2	Metric	Metric
A3HG180-FR07K-U1D	5/8-11 UNC	29	G 3/4	75	12.7	56	44.45 ⁰ / _{-0.05}	49.39 ⁰ / _{-0.18}	152.4 ⁰ / _{-0.05}	67		32	11.11 ^{+0.03} / ₀	161.6	21.5	39	Conforms to ISO 3019-1	Unified	Unified
A3HG180-FR07K-U2D	M16	29	G 3/4	75	12.7	56	44.45 ⁰ / _{-0.05}	49.39 ⁰ / _{-0.18}	152.4 ⁰ / _{-0.05}	67	1/2-13 UNC	32	11.11 ^{+0.03} / ₀	161.6	21.5	39	Conforms to ISO 3019-1	BSPP	Metric
A3HG180-FR07K-J1D	M16	29	G 3/4	75	12.7	56	44.45 ⁰ / _{-0.05}	49.39 ⁰ / _{-0.18}	152.4 ⁰ / _{-0.05}	67		32	11.11 ^{+0.03} / ₀	161.6	21.5	39	Conforms to ISO 3019-1	Rc	Metric

Pilot Port

Pilot port is common to that of "A3HG16-FR07K-E1C/U1C/U2C/J1C" (except the height dimension from the center of the pump). Refer to page A-174 for the dimensions of pilot port.

Drain Port

Drain port is common to that of pressure compensator model. Refer to page A-169 or A-170 for the dimensions of drain port.

Foot Mtg.:A3HG145-LR07K-E1D/E2D/U1D/U2D/J1D, A3HG180-LR07K-E1D/E2D/U1D/U2D/J1D

Mounting bracket is common to that of pressure compensator model. Refer to pages A-169 and A-170 for the dimensions of mounting bracket.

A3HG Series High Pressure Variable Displacement Piston Pumps Constant Power Control Type With External Pilot

A3HG Series

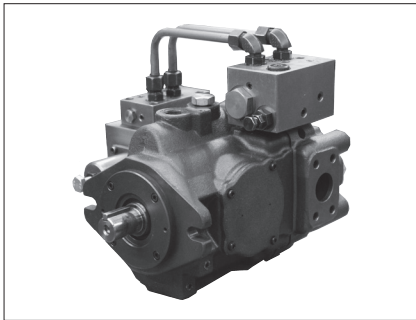

Graphic Symbols

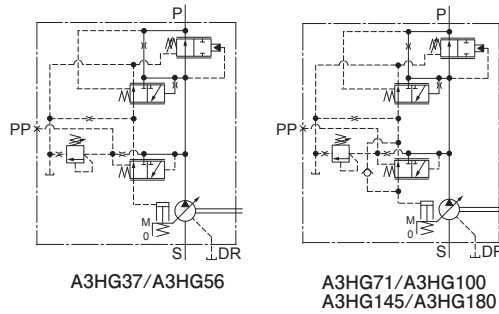

Specifications

Model Numbers	Geometric Displacement cm ³ /rev	Minimum Adjustment Flow cm ³ /rev	Operating Pressure MPa		Minimum Adjustment Pressure MPa	Shaft Speed Range r/min		Approx. Mass kg		
			Rated ^{★1}	Intermittent		Max. ^{★2}	Min.	Flange Mtg.	Foot Mtg.	
A3HG37- *R09V * - * - * C-10	37.1	16	31.5	35	5	2700	600	37	45.5	
A3HG37- *R09V * - * - * D-10									44.5	
A3HG56- *R09V * - * - * C-10	56.3	35				2500	600	45	53.5	
A3HG56- *R09V * - * - * D-10									43	50.5
A3HG71- *R09V * - * - * E1D/E2D-10	70.7	45				2300	600	56	82	
A3HG71- *R09V * - * - * U1D/U2D/J1D-10									52.5	60
A3HG100- *R09V * - * - * K-E1D/E2D-10	100.5	63				2100	600	67.5	92.5	
A3HG100- *R09V * - * - * SP * -E1D/E2D-10									67	92
A3HG100- *R09V * - * - * U1D/U2D/J1D-10									67	94
A3HG145- *R09V * - * - * K-E1D/E2D-10	145.2	95				1800	600	83.5	109.5	
A3HG145- *R09V * - * - * SP * -E1D/E2D-10									83	109
A3HG145- *R09V * - * - * U1D/U2D/J1D-10									83	110.5
A3HG180- *R09V * - * - * K-E1D/E2D-10	180.7	130	1800	600	101	127				
A3HG180- *R09V * - * - * SP * -E1D/E2D-10						100.5	126.5			
A3HG180- *R09V * - * - * U1D/U2D/J1D-10						100.5	128			

★1. Consult Yuken when pump is used over rated pressure because there is a restriction on operating condition.

★2. The maximum shaft speeds shown in the above table are at suction pressure 0 kPa.

Model Number Designation

A3HG37	-F	R	09V	B	-K	-E1				D	-10			
Series Number	Mounting	Direction of Rotation	Control Type	Input Power Setting	Shaft Extension	Main Pump Mtg. Flange Connecting Port / Pipe Flange Thread Second Pump Mtg.				Number of Pump Mtg. Bolts	Design Number			
A3HG37 (37.1 cm ³ /rev)	F: Flange Mtg. L: Foot Mtg.	(Viewed from Shaft End) R: Clockwise (Normal)	09V: Constant Power Control Type With External Pilot	B:7.5 kW N:110 kW Refer to the table on following page for combination.	K: Keyed Shaft SP: Splined Shaft (High Torque) SP1: Splined Shaft (Conforms to ISO 3019-1)	Code	Main Pump Mtg. Flange	Connecting Port	Pipe Flange Thread	Second Pump Mtg.	C: 2 D: 4 D: 4	10		
A3HG56 (56.3 cm ³ /rev)						E1	ISO 3019-2	Metric	Metric	ISO 3019-2				10
A3HG71 (70.7 cm ³ /rev)						E2	ISO 3019-2	Metric	Metric	ISO 3019-1				10
A3HG100 (100.5 cm ³ /rev)						U1	ISO 3019-1	Unified	Unified	ISO 3019-1				10
A3HG145 (145.2 cm ³ /rev)						U2	ISO 3019-1	BSP	Metric	ISO 3019-1				10
A3HG180 (180.7 cm ³ /rev)						J1	ISO 3019-1	Rc	Metric	ISO 3019-1				10

Combination of Pump Series and Input Power Setting

Mark "○" in the table below refers to available combinations.

Model Numbers	Input Power Setting kW											
	B: 7.5	C: 11	D: 15	E: 18.5	F: 22	G: 30	H: 37	J: 45	K: 55	L: 75	M: 90	N: 110
A3HG37	○	○	○	○	○							
A3HG56		○	○	○	○	○	○					
A3HG71			○	○	○	○	○	○				
A3HG100				○	○	○	○	○	○			
A3HG145					○	○	○	○	○	○	○	
A3HG180						○	○	○	○	○	○	○

Pipe Flange Kits

Pipe flange mouting surface conforms to SAE J 518, 4 bolt split flange.

Pipe flange kits are not available. Contact us for details.

Typical Performance Characteristics of Type "A3HG37/56/71" at Viscosity 32 mm²/s [ISO VG32 Oils, 40°C]

A3HG37

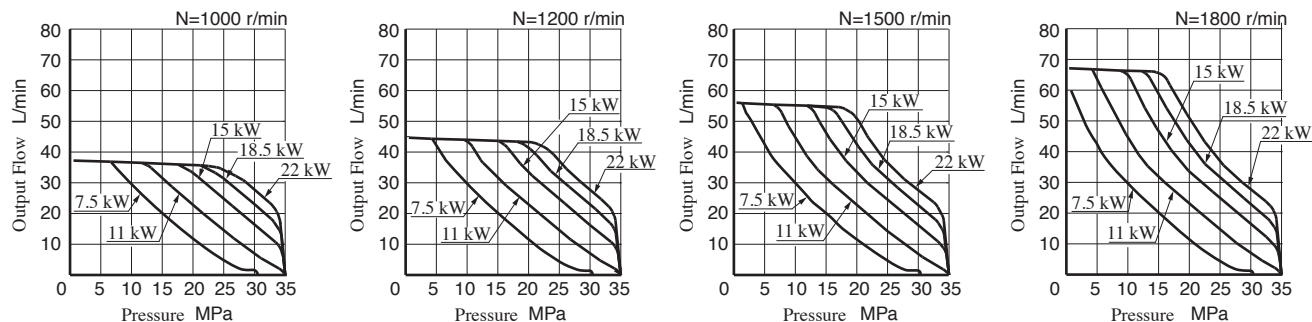

A3HG56

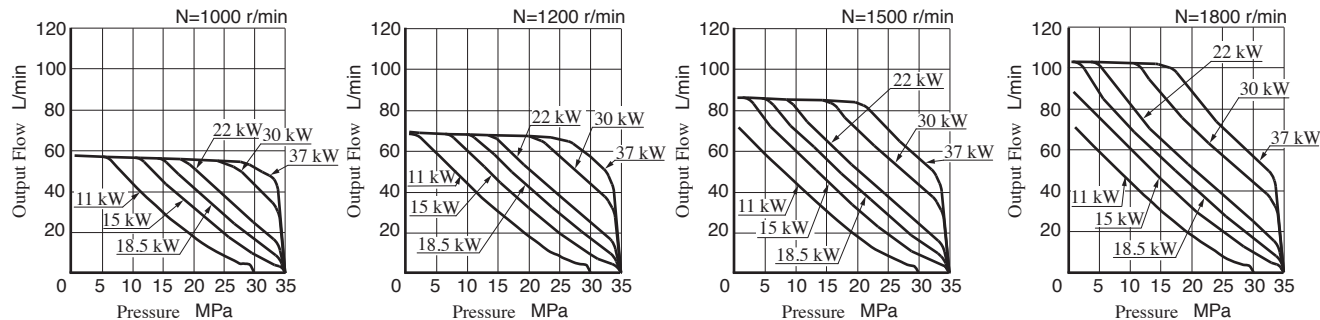

A3HG71

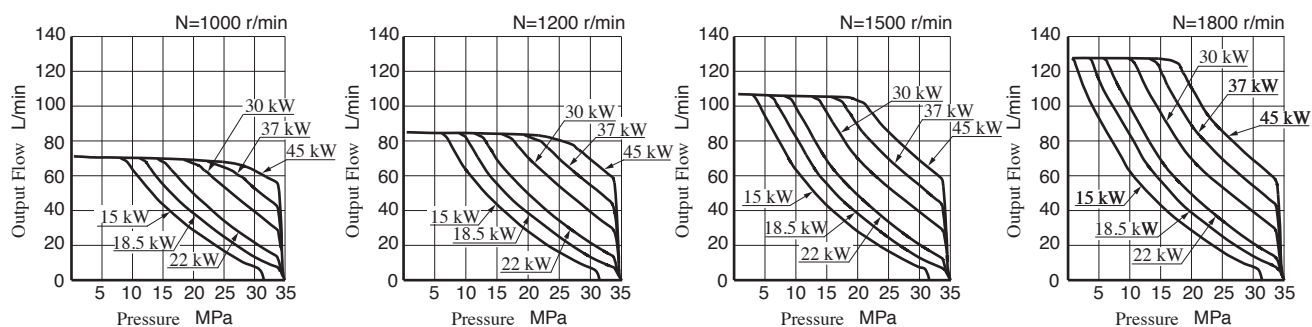

★1. Pumps are adjusted to the required power before shipment, but in case of oil temperature rise (increase of drain) the input power may exceed the adjusted power. In that case phase re-adjust screw referring to instruction manual.

★2. In case of over 1800 r/min of shaft speed, the input power may exceed the adjusted power. In that case phase re-adjust screw referring to instruction manual.

Typical Performance Characteristics of Type "A3HG100/145/180" at Viscosity 32 mm²/s [ISO VG32 Oils, 40°C]

● A3HG100

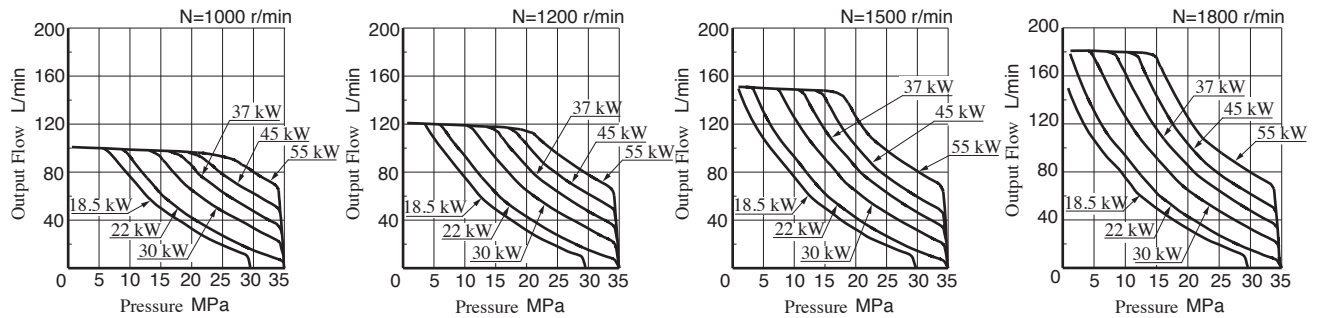

● A3HG145

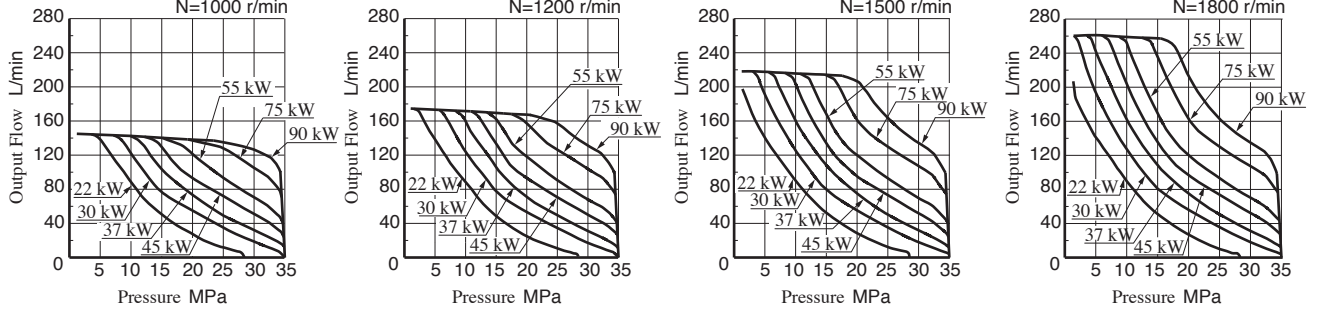

● A3HG180

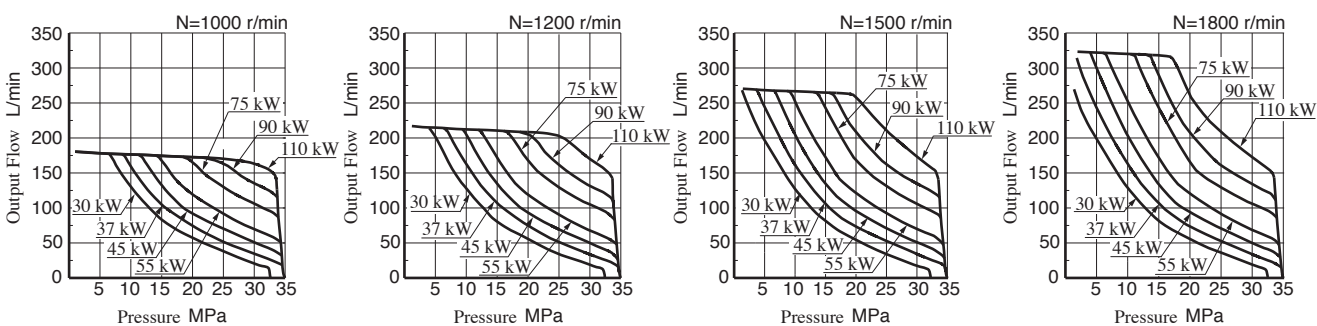

- ★1. Pumps are adjusted to the required power before shipment, but in case of oil temperature rise (increase of drain) the input power may exceed the adjusted power. In that case phase re-adjust screw referring to instruction manual.
- ★2. In case of over 1800 r/min of shaft speed, the input power may exceed the adjusted power. In that case phase re-adjust screw referring to instruction manual(except the model of "A3HG145/A3HG180").

Flange Mtg. Two Bolts:A3HG37-FR09V*-K-E1C/E2C/U1C/U2C/J1C

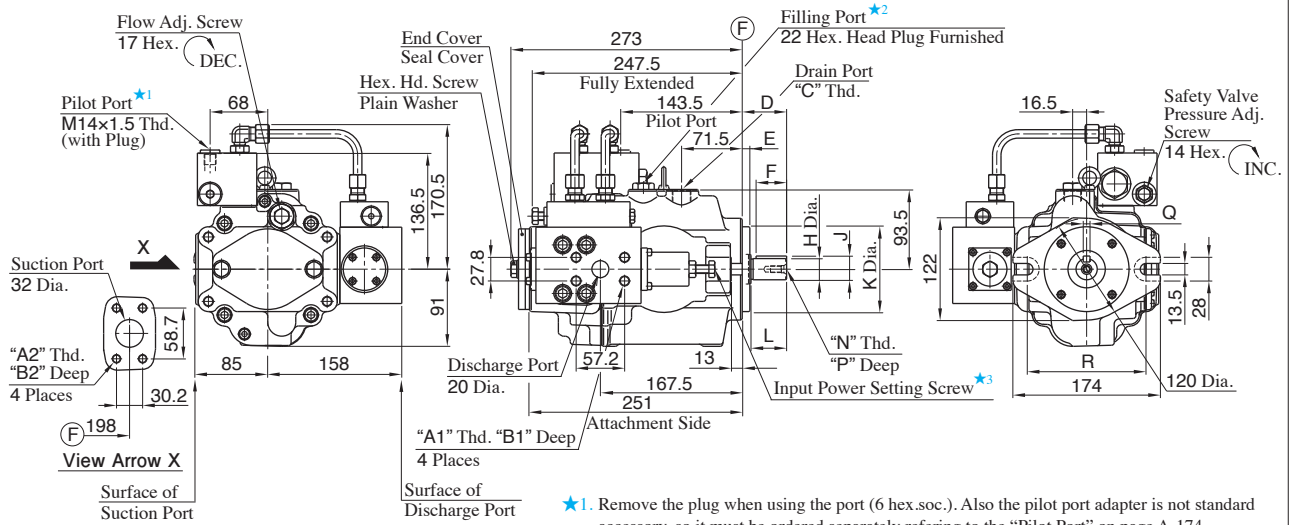

- ★1. Remove the plug when using the port (6 hex.soc.). Also the pilot port adapter is not standard accessory, so it must be ordered separately referring to the "Pilot Port" on page A-174.
- ★2. Install the pump so that the "Filling Port" is at the top.
- ★3. Do not touch the screw because it is adjusted at the time of shipment.

Model Numbers	A1	A2	B1	B2	C	D	E	F	H	J	K	L	N	P	Q	R	Mounting Flange	Connecting Port	Pipe Flange Threads
A3HG37-FR09V*-K-E1C/E2C	M12	M10	22	18	M22X1.5	52	9	36	25 ^{+0.009} _{-0.004}	28 ^{+0.009} _{-0.294}	100 ⁰ _{-0.054}	42	M8	19	8 ⁰ _{-0.036}	140	Conforms to ISO 3019-2	Metric	Metric
A3HG37-FR09V*-K-U1C	7/16-14 UNC		20		G 1/2	46	9.7	32	25.4 ⁰ _{-0.05}	28.18 ⁰ _{-0.18}	101.6 ⁰ _{-0.05}	38	1/4-20 UNC	16	6.35 ^{+0.03} ₀	146	Conforms to ISO 3019-1	Unified	Unified
A3HG37-FR09V*-K-U2C	M12	M10	22	18	G 1/2	46	9.7	32	25.4 ⁰ _{-0.05}	28.18 ⁰ _{-0.18}	101.6 ⁰ _{-0.05}	38		16	6.35 ^{+0.03} ₀	146	Conforms to ISO 3019-1	BSP	Metric
A3HG37-FR09V*-K-J1C	M12	M10	22	18	G 1/2	46	9.7	32	25.4 ⁰ _{-0.05}	28.18 ⁰ _{-0.18}	101.6 ⁰ _{-0.05}	38	16	6.35 ^{+0.03} ₀	146	Conforms to ISO 3019-1	Rc	Metric	

Flange Mtg. Four Bolts:A3HG37-FR09V*-K-E1D/E2D/U1D/U2D/J1D

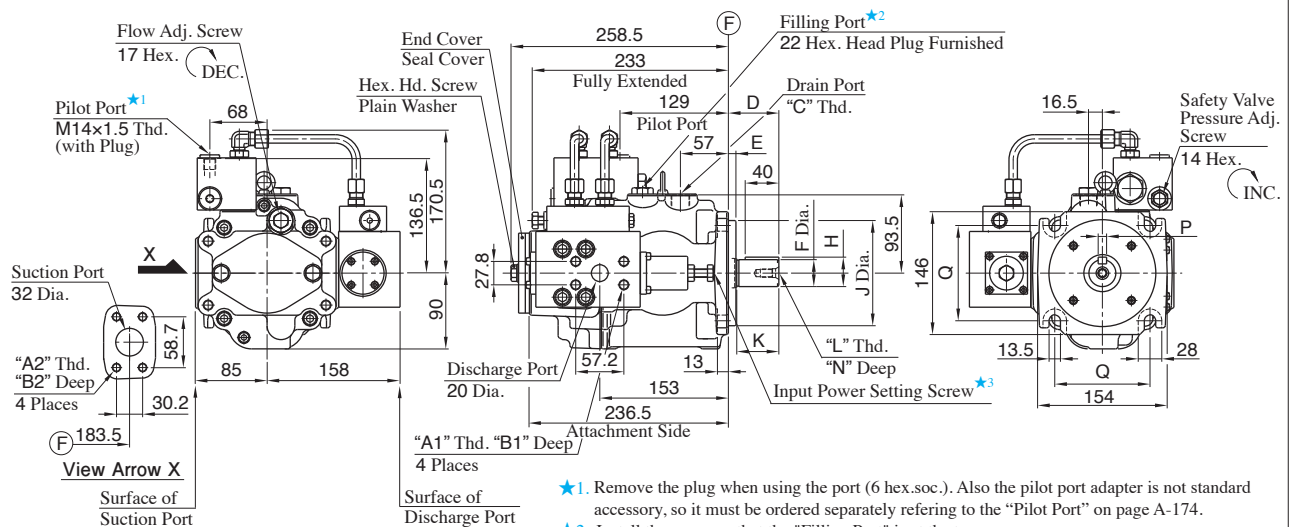

- ★1. Remove the plug when using the port (6 hex.soc.). Also the pilot port adapter is not standard accessory, so it must be ordered separately referring to the "Pilot Port" on page A-174.
- ★2. Install the pump so that the "Filling Port" is at the top.
- ★3. Do not touch the screw because it is adjusted at the time of shipment.

Model Numbers	A1	A2	B1	B2	C	D	E	F	H	J	K	L	N	P	Q	Mounting Flange	Connecting Port	Pipe Flange Threads
A3HG37-FR09V*-K-E1D/E2D	M12	M10	22	18	M22X1.5	60	9	32 ^{+0.018} _{+0.002}	35 ^{+0.018} _{-0.288}	125 ⁰ _{-0.063}	50	M10	22	10 ⁰ _{-0.036}	113.2	Conforms to ISO 3019-2	Metric	Metric
A3HG37-FR09V*-K-U1D	7/16-14 UNC		20		G 1/2	56	12.7	31.75 ⁰ _{-0.05}	35.32 ⁰ _{-0.18}	127 ⁰ _{-0.05}	48	5/16-18 UNC	19	7.94 ^{+0.03} ₀	114.5	Conforms to ISO 3019-1	Unified	Unified
A3HG37-FR09V*-K-U2D	M12	M10	22	18	G 1/2	56	12.7	31.75 ⁰ _{-0.05}	35.32 ⁰ _{-0.18}	127 ⁰ _{-0.05}	48		19	7.94 ^{+0.03} ₀	114.5	Conforms to ISO 3019-1	BSP	Metric
A3HG37-FR09V*-K-J1D	M12	M10	22	18	G 1/2	56	12.7	31.75 ⁰ _{-0.05}	35.32 ⁰ _{-0.18}	127 ⁰ _{-0.05}	48	19	7.94 ^{+0.03} ₀	114.5	Conforms to ISO 3019-1	Rc	Metric	

Pilot Port

Pilot port is common to that of "A3HG16-FR07K-E1C/U1C/U2C/J1C" (except the height dimension from the center of the pump). Refer to page A-174 for the dimensions of pilot port.

Drain Port

Drain port is common to that of pressure compensator model. Refer to page A-163 or A-164 for the dimensions of drain port.

Foot Mtg.:A3HG37-LR09V*-K-E1C/E2C/U1C/U2C/J1C, A3HG37-LR09V*-K-E1D/E2D/U1D/U2D/J1D

Mounting bracket is common to that of pressure compensator model (except max. height dimension). Refer to pages A-163 and A-164 for the dimensions of mounting bracket.

Flange Mtg. Two Bolts:A3HG56-FR09V*-K-E1C/E2C/U1C/U2C/J1C

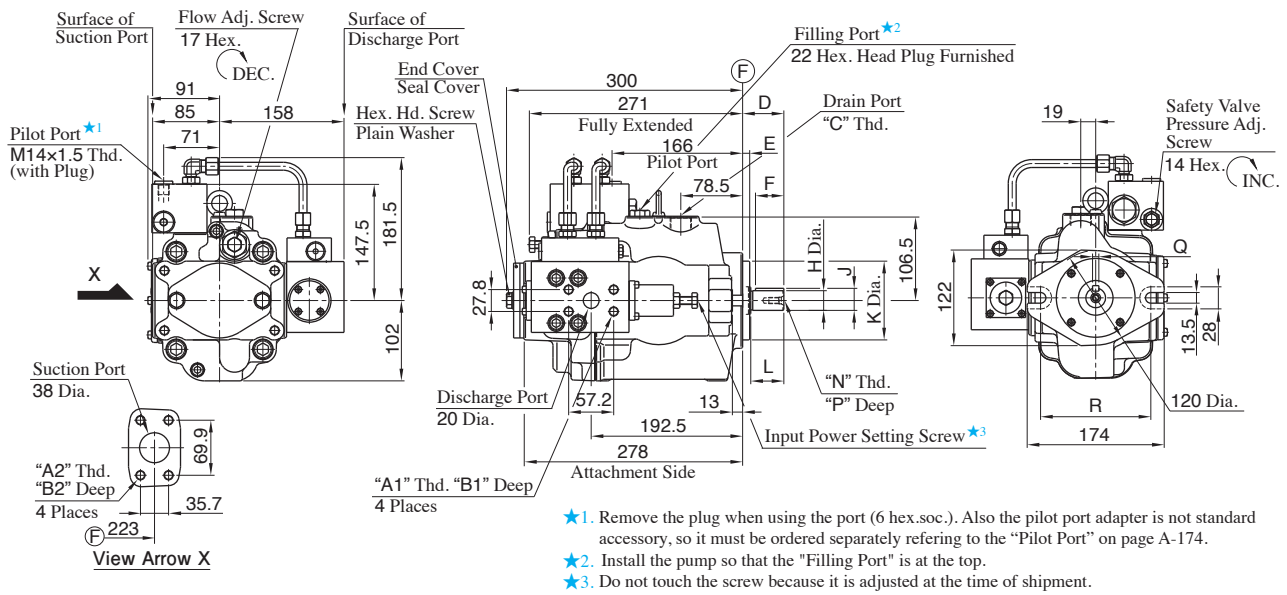

Model Numbers	A1	A2	B1	B2	C	D	E	F	H	J	K	L	N	P	Q	R	Mounting Flange	Connecting Port	Pipe Flange Threads
A3HG56-FR09V*-K-E1C/E2C	M12	M12	22	22	M27X2	52	9	36	25 ^{+0.009} _{-0.004}	28 ^{+0.009} _{-0.294}	100 ⁰ _{-0.054}	42	M8	19	8 ⁰ _{-0.036}	140	Conforms to ISO 3019-2	Metric	Metric
A3HG56-FR09V*-K-U1C	7/16-14 UNC	1/2-13 UNC	20	21	G 3/4	46	9.7	32	25.4 ⁰ _{-0.05}	28.18 ⁰ _{-0.18}	101.6 ⁰ _{-0.05}	38	1/4-20 UNC	16	6.35 ^{+0.03} ₀	146	Conforms to ISO 3019-1	Unified	Unified
A3HG56-FR09V*-K-U2C	M12	M12	22	22	G 3/4	46	9.7	32	25.4 ⁰ _{-0.05}	28.18 ⁰ _{-0.18}	101.6 ⁰ _{-0.05}	38	1/4-20 UNC	16	6.35 ^{+0.03} ₀	146	Conforms to ISO 3019-1	BSPP	Metric
A3HG56-FR09V*-K-J1C	M12	M12	22	22	G 3/4	46	9.7	32	25.4 ⁰ _{-0.05}	28.18 ⁰ _{-0.18}	101.6 ⁰ _{-0.05}	38	16	6.35 ^{+0.03} ₀	146	Conforms to ISO 3019-1	Rc	Metric	

Flange Mtg. Four Bolts:A3HG56-FR09V*-K-E1D/E2D/U1D/U2D/J1D

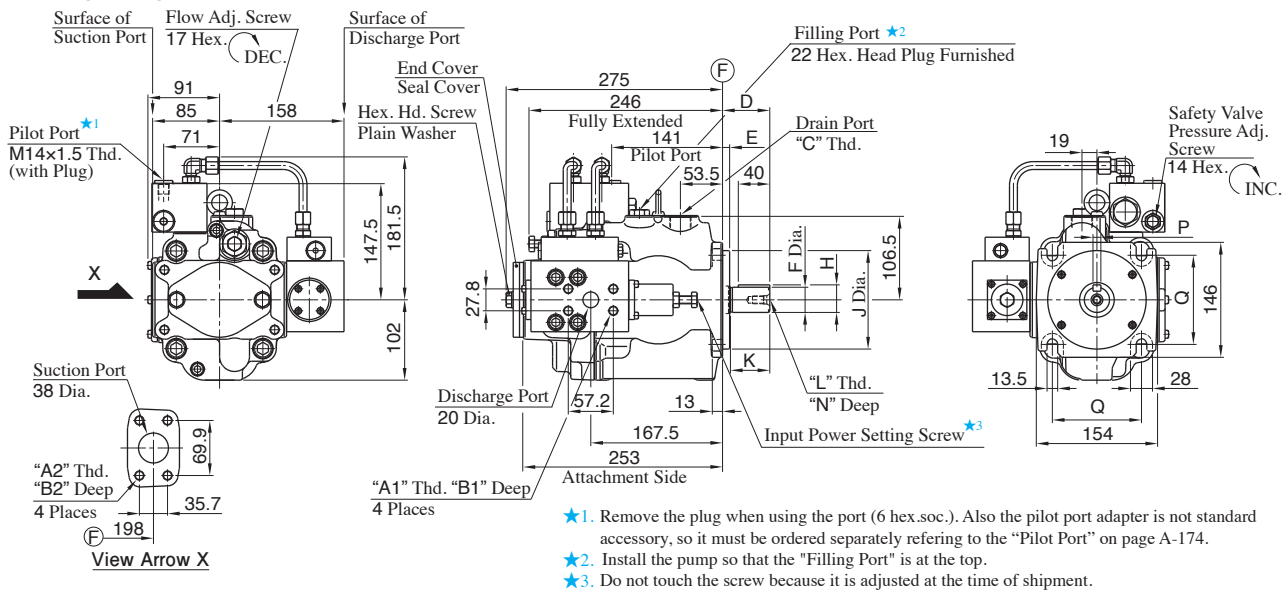

Model Numbers	A1	A2	B1	B2	C	D	E	F	H	J	K	L	N	P	Q	Mounting Flange	Connecting Port	Pipe Flange Threads
A3HG56-FR09V*-K-E1D/E2D	M12	M12	22	22	M27X2	60	9	32 ^{+0.018} _{+0.002}	35 ^{+0.018} _{-0.288}	125 ⁰ _{-0.063}	50	M10	22	10 ⁰ _{-0.036}	113.2	Conforms to ISO 3019-2	Metric	Metric
A3HG56-FR09V*-K-U1D	7/16-14 UNC	1/2-13 UNC	20	21	G 3/4	56	12.7	31.75 ⁰ _{-0.05}	35.32 ⁰ _{-0.18}	127 ⁰ _{-0.05}	48	5/16-18 UNC	19	7.94 ^{+0.03} ₀	114.5	Conforms to ISO 3019-1	Unified	Unified
A3HG56-FR09V*-K-U2D	M12	M12	22	22	G 3/4	56	12.7	31.75 ⁰ _{-0.05}	35.32 ⁰ _{-0.18}	127 ⁰ _{-0.05}	48	5/16-18 UNC	19	7.94 ^{+0.03} ₀	114.5	Conforms to ISO 3019-1	BSPP	Metric
A3HG56-FR09V*-K-J1D	M12	M12	22	22	G 3/4	56	12.7	31.75 ⁰ _{-0.05}	35.32 ⁰ _{-0.18}	127 ⁰ _{-0.05}	48	19	7.94 ^{+0.03} ₀	114.5	Conforms to ISO 3019-1	Rc	Metric	

Pilot Port

Pilot port is common to that of "A3HG16-FR07K-E1C/U1C/U2C/J1C" (except the height dimension from the center of the pump). Refer to page A-174 for the dimensions of pilot port.

Drain Port

Drain port is common to that of pressure compensator model. Refer to page A-165 or A-166 for the dimensions of drain port.

Foot Mtg.:A3HG56-LR09V*-K-E1C/E2C/U1C/U2C/J1C, A3HG56-LR09V*-K-E1D/E2D/U1D/U2D/J1D

Mounting bracket is common to that of pressure compensator model (except max. height dimension). Refer to pages A-165 and A-166 for the dimensions of mounting bracket.

Flange Mtg.:A3HG71-FR09V*-K-E1D/E2D/U1D/U2D/J1D

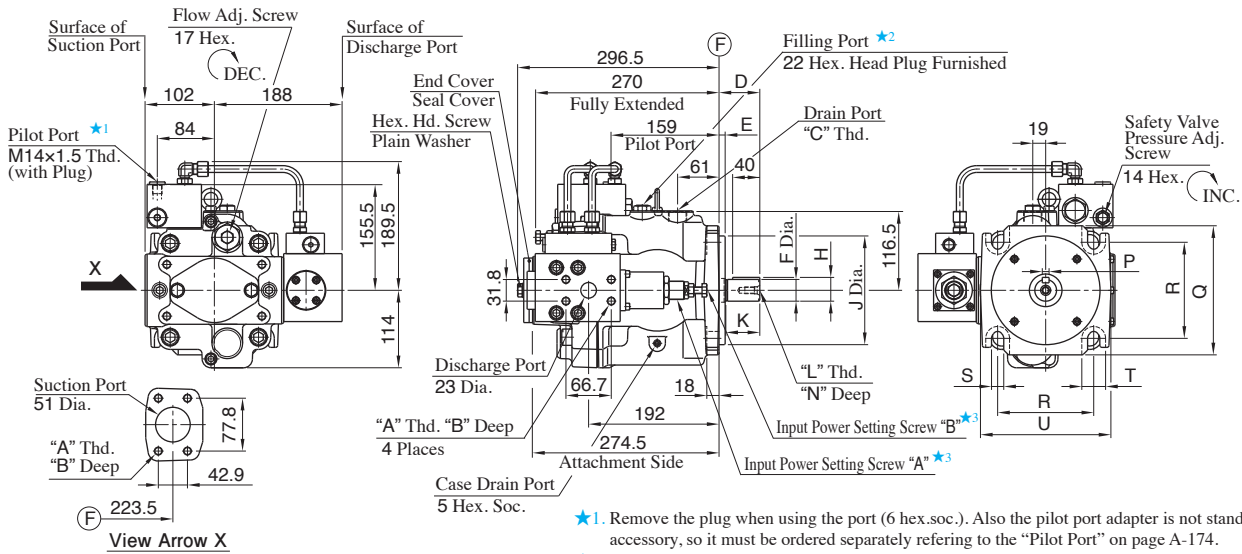

- ★1. Remove the plug when using the port (6 hex.soc.). Also the pilot port adapter is not standard accessory, so it must be ordered separately referring to the "Pilot Port" on page A-174.
- ★2. Install the pump so that the "Filling Port" is at the top.
- ★3. Do not touch the screw because it is adjusted at the time of shipment.

Model Numbers	A	B	C	D	E	F	H	J	K	L	N	P	Q	R	S	T	U	Mounting Flange	Connecting Port	Pipe Flange Threads
A3HG71-FR09V*-K-E1D/E2D	M12	22	M27X2	60	9	32 ^{+0.018} / _{-0.002}	35 ^{+0.018} / _{-0.288}	160 ⁰ / _{-0.063}	50	M10	22	10 ⁰ / _{-0.036}	190	141.4	18	35	192	Conforms to ISO 3019-2	Metric	Metric
A3HG71-FR09V*-K-UID	1/2-13 UNC	21	G 3/4	56	12.7	31.75 ⁰ / _{-0.05}	35.32 ⁰ / _{-0.18}	127 ⁰ / _{-0.05}	48	5/16-18 UNC	19	7.94 ^{+0.03} / ₀	143	114.5	13.5	28	155	Conforms to ISO 3019-1	Unified	Unified
A3HG71-FR09V*-K-U2D	M12	22	G 3/4	56	12.7	31.75 ⁰ / _{-0.05}	35.32 ⁰ / _{-0.18}	127 ⁰ / _{-0.05}	48	5/16-18 UNC	19	7.94 ^{+0.03} / ₀	143	114.5	13.5	28	155	Conforms to ISO 3019-1	BSP	Metric
A3HG71-FR09V*-K-J1D	M12	22	G 3/4	56	12.7	31.75 ⁰ / _{-0.05}	35.32 ⁰ / _{-0.18}	127 ⁰ / _{-0.05}	48	5/16-18 UNC	19	7.94 ^{+0.03} / ₀	143	114.5	13.5	28	155	Conforms to ISO 3019-1	Rc	Metric

Flange Mtg.:A3HG100-FR09V*-K-E1D/E2D/U1D/U2D/J1D

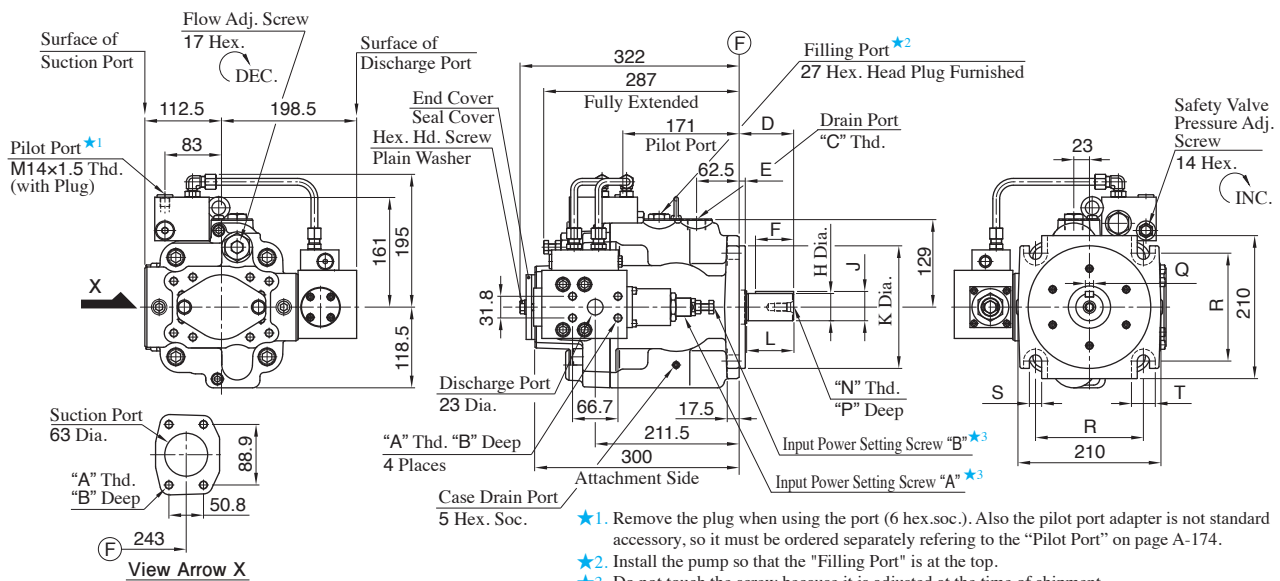

- ★1. Remove the plug when using the port (6 hex.soc.). Also the pilot port adapter is not standard accessory, so it must be ordered separately referring to the "Pilot Port" on page A-174.
- ★2. Install the pump so that the "Filling Port" is at the top.
- ★3. Do not touch the screw because it is adjusted at the time of shipment.

Model Numbers	A	B	C	D	E	F	H	J	K	L	N	P	Q	R	S	T	U	Mounting Flange	Connecting Port	Pipe Flange Threads
A3HG100-FR09V*-K-E1D/E2D	M12	22	M27X2	80	9	40 ^{+0.018} / _{-0.002}	43 ^{+0.018} / _{-0.288}	180 ⁰ / _{-0.063}	70	M12	28	12 ⁰ / _{-0.043}	158.4	18	35			Conforms to ISO 3019-2	Metric	Metric
A3HG100-FR09V*-K-UID	1/2-13 UNC	21	G 3/4	62	12.7	38.1 ⁰ / _{-0.05}	42.36 ⁰ / _{-0.18}	152.4 ⁰ / _{-0.05}	54	7/16-14 UNC	28	9.53 ^{+0.03} / ₀	161.6	21.5	39			Conforms to ISO 3019-1	Unified	Unified
A3HG100-FR09V*-K-U2D	M12	22	G 3/4	62	12.7	38.1 ⁰ / _{-0.05}	42.36 ⁰ / _{-0.18}	152.4 ⁰ / _{-0.05}	54	7/16-14 UNC	28	9.53 ^{+0.03} / ₀	161.6	21.5	39			Conforms to ISO 3019-1	BSP	Metric
A3HG100-FR09V*-K-J1D	M12	22	G 3/4	62	12.7	38.1 ⁰ / _{-0.05}	42.36 ⁰ / _{-0.18}	152.4 ⁰ / _{-0.05}	54	7/16-14 UNC	28	9.53 ^{+0.03} / ₀	161.6	21.5	39			Conforms to ISO 3019-1	Rc	Metric

Pilot Port

Pilot port is common to that of "A3HG16-FR07K-E1C/U1C/U2C/J1C" (except the height dimension from the center of the pump). Refer to page A-174 for the dimensions of pilot port.

Drain Port

Drain port is common to that of pressure compensator model. Refer to page A-167 or A-168 for the dimensions of drain port.

Foot Mtg.:A3HG71-LR09V*-K-E1D/E2D/U1D/U2D/J1D, A3HG100-LR09V*-K-E1D/E2D/U1D/U2D/J1D

Mounting bracket is common to that of pressure compensator model (except max. height dimension). Refer to pages A-167 and A-168 for the dimensions of mounting bracket.

Flange Mtg.:A3HG145-FR09V*-K-E1D/E2D/U1D/U2D/J1D

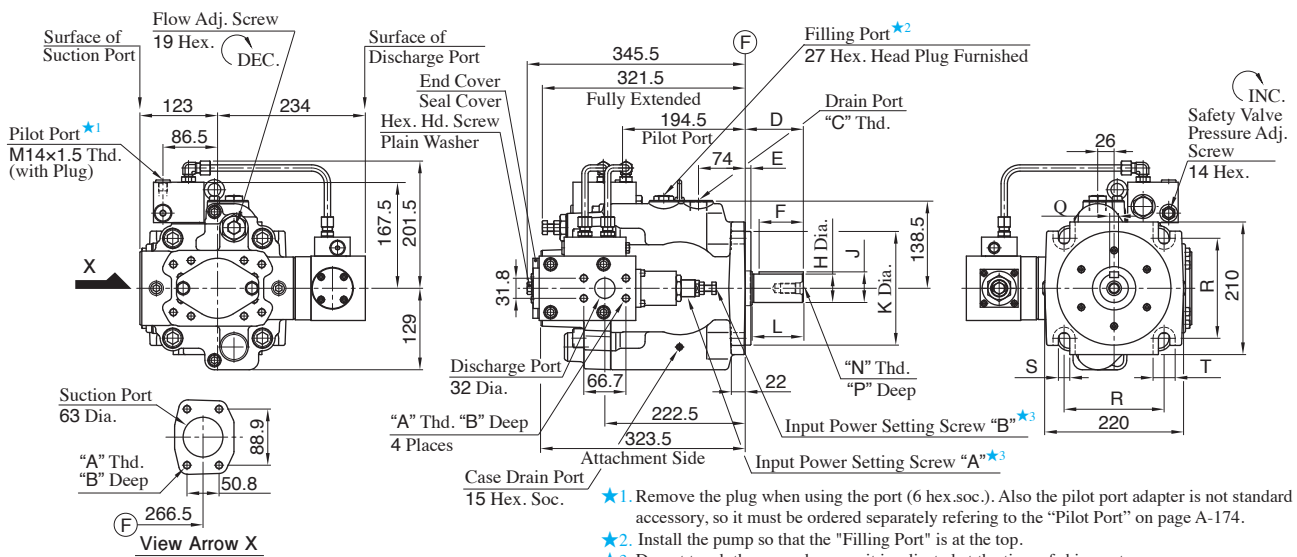

- ★1. Remove the plug when using the port (6 hex.soc.). Also the pilot port adapter is not standard accessory, so it must be ordered separately referring to the "Pilot Port" on page A-174.
- ★2. Install the pump so that the "Filling Port" is at the top.
- ★3. Do not touch the screw because it is adjusted at the time of shipment.

Model Numbers	A	B	C	D	E	F	H	J	K	L	N	P	Q	R	S	T	Mounting Flange	Connecting Port	Pipe Flange Threads
A3HG145-FR09V*-K-E1D/E2D	M12	22	M27X2	92	9	70	45 ^{+0.018} / _{+0.002}	48.5 ^{+0.018} / _{-0.288}	180 ⁰ / _{-0.063}	82	M16	36	14 ⁰ / _{-0.043}	158.4	18	35	Conforms to ISO 3019-2	Metric	Metric
A3HG145-FR09V*-K-U1D	1/2-13 UNC	21	G 3/4	75	12.7	56	44.45 ⁰ / _{-0.05}	49.39 ⁰ / _{-0.18}	152.4 ⁰ / _{-0.05}	67		32	11.11 ^{+0.03} / ₀	161.6	21.5	39	Conforms to ISO 3019-1	Unified	Unified
A3HG145-FR09V*-K-U2D	M12	22	G 3/4	75	12.7	56	44.45 ⁰ / _{-0.05}	49.39 ⁰ / _{-0.18}	152.4 ⁰ / _{-0.05}	67	1/2-13 UNC	32	11.11 ^{+0.03} / ₀	161.6	21.5	39	Conforms to ISO 3019-1	BSPP	Metric
A3HG145-FR09V*-K-J1D	M12	22	G 3/4	75	12.7	56	44.45 ⁰ / _{-0.05}	49.39 ⁰ / _{-0.18}	152.4 ⁰ / _{-0.05}	67		32	11.11 ^{+0.03} / ₀	161.6	21.5	39	Conforms to ISO 3019-1	Rc	Metric

Flange Mtg.:A3HG180-FR09V*-K-E1D/E2D/U1D/U2D/J1D

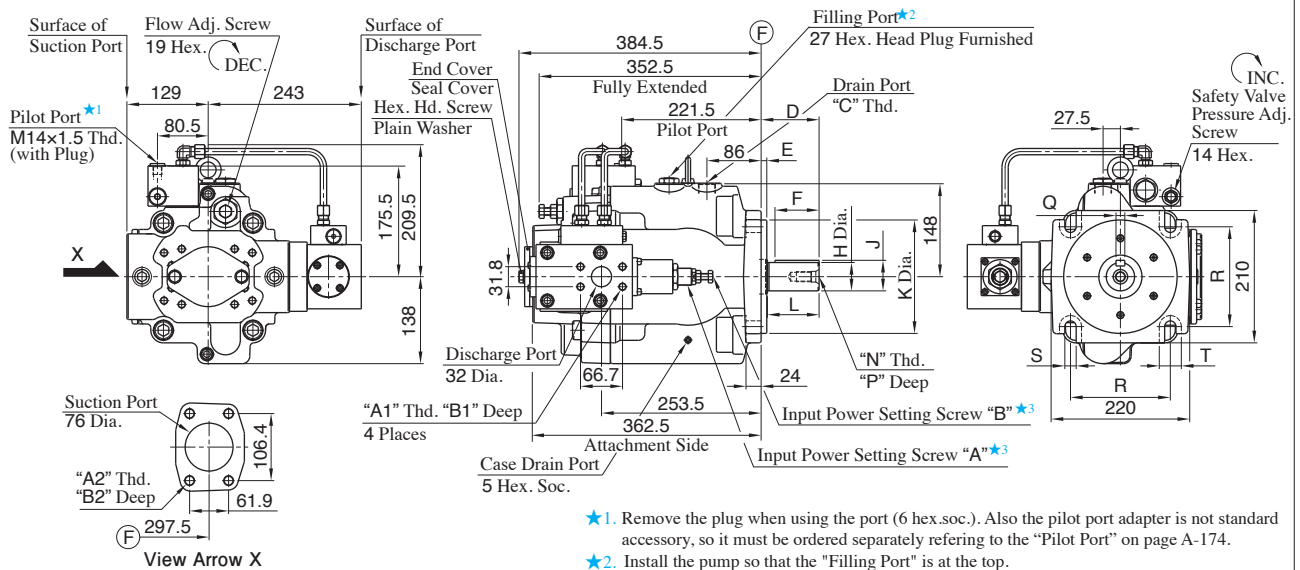

- ★1. Remove the plug when using the port (6 hex.soc.). Also the pilot port adapter is not standard accessory, so it must be ordered separately referring to the "Pilot Port" on page A-174.
- ★2. Install the pump so that the "Filling Port" is at the top.
- ★3. Do not touch the screw because it is adjusted at the time of shipment.

Model Numbers	A1	A2	B1	B2	C	D	E	F	H	J	K	L	N	P	Q	R	S	T	Mounting Flange	Connecting Port	Pipe Flange Threads
A3HG180-FR09V*-K-E1D/E2D	M12	M16	22	29	M27X2	92	9	70	45 ^{+0.018} / _{+0.002}	48.5 ^{+0.018} / _{-0.288}	180 ⁰ / _{-0.063}	82	M16	36	14 ⁰ / _{-0.043}	158.4	18	35	Conforms to ISO 3019-2	Metric	Metric
A3HG180-FR09V*-K-U1D	1/2-13 UNC	5/8-11 UNC	21	29	G 3/4	75	12.7	56	44.45 ⁰ / _{-0.05}	49.39 ⁰ / _{-0.18}	152.4 ⁰ / _{-0.05}	67		32	11.11 ^{+0.03} / ₀	161.6	21.5	39	Conforms to ISO 3019-1	Unified	Unified
A3HG180-FR09V*-K-U2D	M12	M16	22	29	G 3/4	75	12.7	56	44.45 ⁰ / _{-0.05}	49.39 ⁰ / _{-0.18}	152.4 ⁰ / _{-0.05}	67	1/2-13 UNC	32	11.11 ^{+0.03} / ₀	161.6	21.5	39	Conforms to ISO 3019-1	BSPP	Metric
A3HG180-FR09V*-K-J1D	M12	M16	22	29	G 3/4	75	12.7	56	44.45 ⁰ / _{-0.05}	49.39 ⁰ / _{-0.18}	152.4 ⁰ / _{-0.05}	67		32	11.11 ^{+0.03} / ₀	161.6	21.5	39	Conforms to ISO 3019-1	Rc	Metric

Pilot Port

Pilot port is common to that of "A3HG16-FR07K-E1C/U1C/U2C/J1C" (except the height dimension from the center of the pump). Refer to page A-174 for the dimensions of pilot port.

Drain Port

Drain port is common to that of pressure compensator model. Refer to page A-169 or A-170 for the dimensions of drain port.

Foot Mtg.:A3HG145-LR09V*-K-E1D/E2D/U1D/U2D/J1D, A3HG180-LR09V*-K-E1D/E2D/U1D/U2D/J1D

Mounting bracket is common to that of pressure compensator model (except max. height dimension). Refer to pages A-169 and A-170 for the dimensions of mounting bracket.

A3HG Series High Pressure Variable Displacement Piston Pumps Load Sensing Type

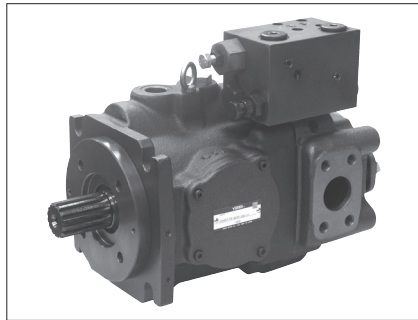

Graphic Symbol

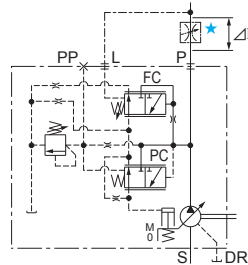

★ A flow control valve is not included with the pump. Install the valve separately.

Specifications

Model Numbers	Geometric Displacement cm ³ /rev	Operating Pressure ^{★1} MPa		Load Sensing Pres. Difference ΔP MPa	Shaft Speed Range r/min		Approx. Mass kg	
		Rated	Intermittent		Max. ^{★3}	Min.	Flange Mtg.	Foot Mtg.
A3HG16- *R14* - *C-11	16.3	31.5	35	1.5 ^{★2} (At the time of shipment)	3600	600	19.5	23.5
A3HG37- *R14* - *C-11	37.1				2700	600	29	37.5
A3HG37- *R14* - *D-11					36.5			
A3HG56- *R14* - *C-11	56.3				2500	600	37	45.5
A3HG56- *R14* - *D-11					35	42.5		
A3HG71- *R14* -E1D/E2D-11	70.7				2300	600	47.5	73.5
A3HG71- *R14* -U1D/U2D/J1D-11					44	51.5		
A3HG100- *R14K-E1D/E2D-11	100.5				2100	600	59	84
A3HG100- *R14SP* -E1D/E2D-11					58.5	83.5		
A3HG100- *R14* -U1D/U2D/J1D-11							58.5	85.5
A3HG145- *R14K-E1D/E2D-11	145.2				1800	600	71	97
A3HG145- *R14SP* -E1D/E2D-11							70.5	96.5
A3HG145- *R14* -U1D/U2D/J1D-11							70.5	98
A3HG180- *R14K-E1D/E2D-11	180.7				1800	600	90.5	116.5
A3HG180- *R14SP* -E1D/E2D-11							90	116
A3HG180- *R14* -U1D/U2D/J1D-11		90	117.5					

- ★1. The operating pressure means pump discharge pressure.
- ★2. Load pressure difference is adjustable in range of 1.0 -3.0 MPa
- ★3. The maximum shaft speeds shown in the above table are at suction pressure 0 kPa.

Model Number Designation

A3HG16	-F	R	14	K	-E1					D	-11
Series Number	Mounting	Direction of Rotation	Control Type	Shaft Extension	Main Pump Mtg. Flange Connecting Port / Pipe Flange Thread Second Pump Mtg.					Number of Pump Mtg. Bolts	Design Number
A3HG16 (16.3 cm ³ /rev)	F: Flange Mtg. L: Foot Mtg.	(Viewed from Shaft End) R: Clockwise (Normal)	14: Load Sensing Type	K: Keyed Shaft SP: Splined Shaft (High Torque) SP1: Splined Shaft (Conforms to ISO 3019-1)						C: 2	11
A3HG37 (37.1 cm ³ /rev)										C: 2 D: 4	11
A3HG56 (56.3 cm ³ /rev)											11
A3HG71 (70.7 cm ³ /rev)										D: 4	11
A3HG100 (100.5 cm ³ /rev)											11
A3HG145 (145.2 cm ³ /rev)											11
A3HG180 (180.7 cm ³ /rev)											11
					Code	Main Pump Mtg. Flange	Connecting Port	Pipe Flange Thread	Second Pump Mtg.		
					E1	ISO 3019-2	Metric	Metric	ISO 3019-2		
					E2	ISO 3019-2	Metric	Metric	ISO 3019-1		
					U1	ISO 3019-1	Unified	Unified	ISO 3019-1		
					U2	ISO 3019-1	BSPP	Metric	ISO 3019-1		
					J1	ISO 3019-1	Rc	Metric	ISO 3019-1		

Pipe Flange Kits

Pipe flange mouting surface conforms to SAE J 518, 4 bolt split flange.
 Pipe flange kits are not available. Contact us for the details.

Typical Performance Characteristics of Type "A3HG71" at Viscosity 32 mm²/s [ISO VG32 Oils, 40°C]

Pressure vs. Output Flow

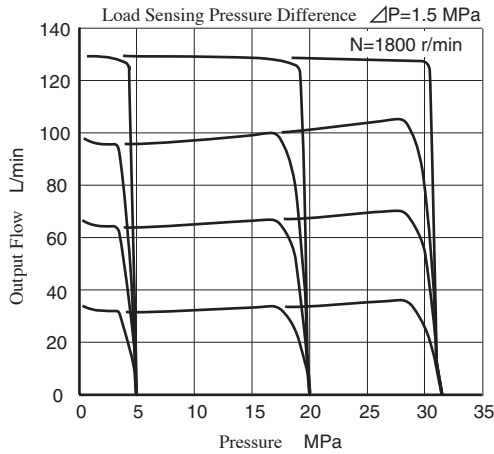

Drain

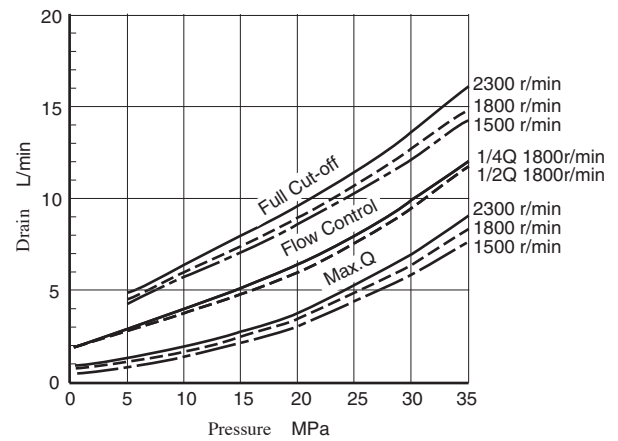

Full Cut-off Power

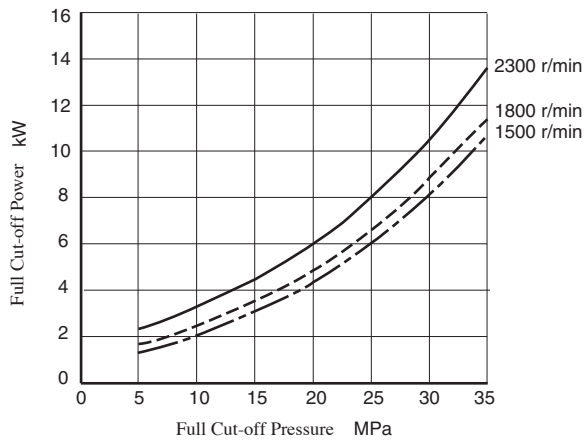

Flange Mtg.:A3HG16-FR14K-E1C/U1C/U2C/J1C

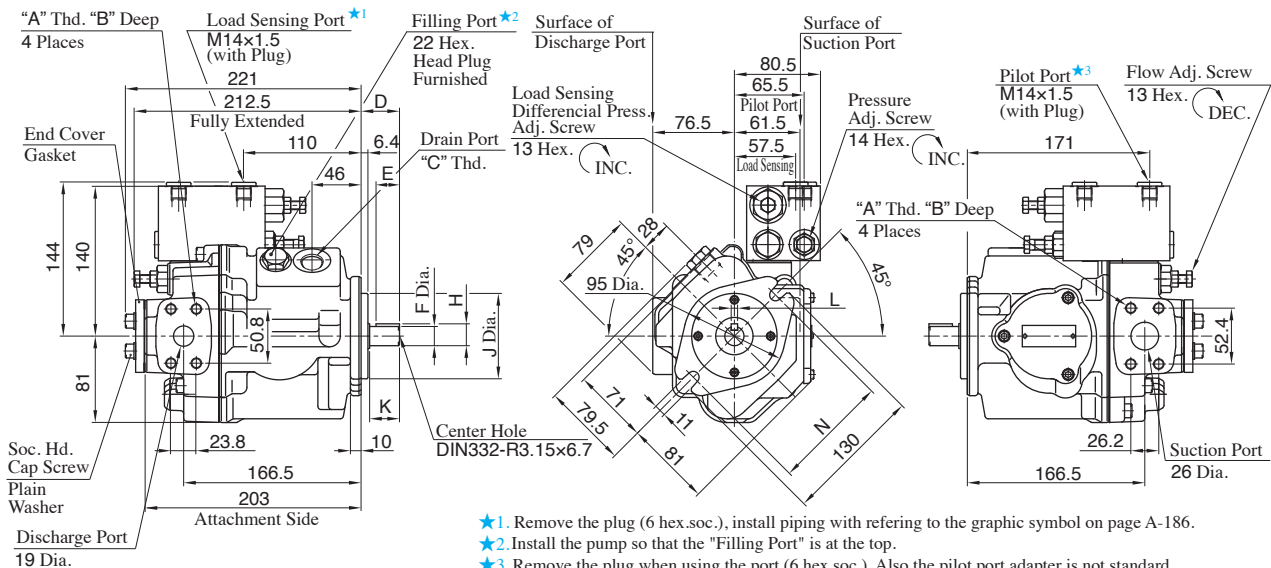

- ★1. Remove the plug (6 hex.soc.), install piping with referring to the graphic symbol on page A-186.
- ★2. Install the pump so that the "Filling Port" is at the top.
- ★3. Remove the plug when using the port (6 hex.soc.). Also the pilot port adapter is not standard accessory, so it must be ordered separately referring to the "Pilot Port" on page A-174.

Model Numbers	A	B	C	D	E	F	H	J	K	L	N	Mounting Flange	Connecting Port	Pipe Flange Threads
A3HG16-FR14K-E1C	M10	19	M22×1.5	36	22	18 ^{+0.008} _{-0.003}	20.5 ^{+0.008} _{-0.133}	80 ⁰ _{-0.046}	28	6 ⁰ _{-0.03}	109	Conforms to ISO 3019-2	Metric	Metric
A3HG16-FR14K-U1C	3/8-16 UNC	17	G 1/2	41	28	19.05 ⁰ _{-0.03}	21.24 ⁰ _{-0.16}	82.55 ⁰ _{-0.05}	33	4.76 ^{+0.03} ₀	106	Conforms to ISO 3019-1	Unified	Unified
A3HG16-FR14K-U2C	M10	19	G 1/2	41	28	19.05 ⁰ _{-0.03}	21.24 ⁰ _{-0.16}	82.55 ⁰ _{-0.05}	33	4.76 ^{+0.03} ₀	106	Conforms to ISO 3019-1	BSP	Metric
A3HG16-FR14K-J1C	M10	19	G 1/2	41	28	19.05 ⁰ _{-0.03}	21.24 ⁰ _{-0.16}	82.55 ⁰ _{-0.05}	33	4.76 ^{+0.03} ₀	106	Conforms to ISO 3019-1	Rc	Metric

Load Sensing Port/Pilot Port

Load sensing port is common to that of pilot port (except the height dimension from the center of the pump). Refer to page A-174 for the dimensions of pilot port.

Drain Port

Drain port is common to that of pressure compensator model. Refer to page A-162 for the dimensions of drain port.

Foot Mtg.:A3HG16-LR14K-E1C/U1C/U2C/J1C

Mounting bracket is common to that of pressure compensator model (except max. height dimension). Refer to page A-162 for the dimensions of mounting bracket.

Flange Mtg. Two Bolts:A3HG37-FR14K-E1C/E2C/U1C/U2C/J1C

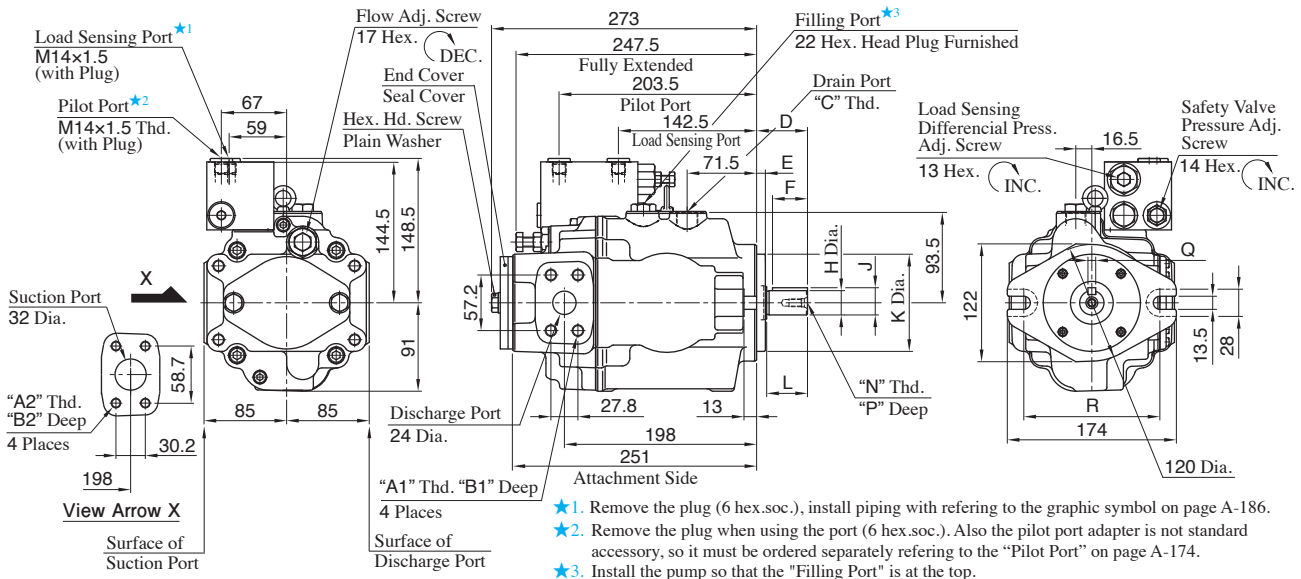

Model Numbers	A1	A2	B1	B2	C	D	E	F	H	J	K	L	N	P	Q	R	Mounting Flange	Connecting Port	Pipe Flange Threads
A3HG37-FR14K-E1C/E2C	M12	M10	22	18	M22X1.5	52	9	36	25 ^{+0.009} _{-0.004}	28 ^{+0.009} _{-0.294}	100 ⁰ _{0.054}	42	M8	19	8 ⁰ _{-0.036}	140	Conforms to ISO 3019-2	Metric	Metric
A3HG37-FR14K-U1C	7/16-14 UNC		20		G 1/2	46	9.7	32	25.4 ⁰ _{-0.05}	28.18 ⁰ _{0.18}	101.6 ⁰ _{0.05}	38	1/4	16	6.35 ^{+0.03} ₀	146	Conforms to ISO 3019-1	Unified	Unified
A3HG37-FR14K-U2C	M12	M10	22	18	G 1/2	46	9.7	32	25.4 ⁰ _{-0.05}	28.18 ⁰ _{0.18}	101.6 ⁰ _{0.05}	38	20 UNC	16	6.35 ^{+0.03} ₀	146	Conforms to ISO 3019-1	BSP	Metric
A3HG37-FR14K-J1C	M12	M10	22	18	G 1/2	46	9.7	32	25.4 ⁰ _{-0.05}	28.18 ⁰ _{0.18}	101.6 ⁰ _{0.05}	38	16	6.35 ^{+0.03} ₀	146	Conforms to ISO 3019-1	Rc	Metric	

Flange Mtg. Four Bolts:A3HG37-FR14K-E1D/E2D/U1D/U2D/J1D

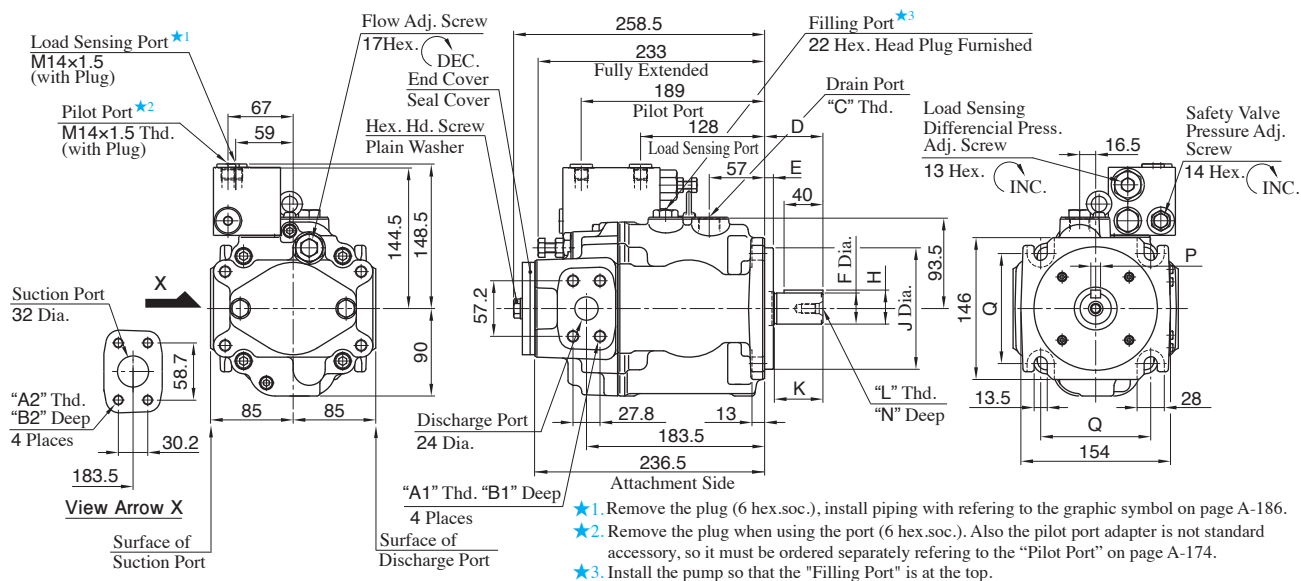

Model Numbers	A1	A2	B1	B2	C	D	E	F	H	J	K	L	N	P	Q	Mounting Flange	Connecting Port	Pipe Flange Threads
A3HG37-FR14K-E1D/E2D	M12	M10	22	18	M22X1.5	60	9	32 ^{+0.018} _{+0.002}	35 ^{+0.018} _{-0.288}	125 ⁰ _{0.063}	50	M10	22	10 ⁰ _{-0.036}	113.2	Conforms to ISO 3019-2	Metric	Metric
A3HG37-FR14K-U1D	7/16-14 UNC		20		G 1/2	56	12.7	31.75 ⁰ _{-0.05}	35.32 ⁰ _{-0.18}	127 ⁰ _{-0.05}	48	5/16-18 UNC	19	7.94 ^{+0.03} ₀	114.5	Conforms to ISO 3019-1	Unified	Unified
A3HG37-FR14K-U2D	M12	M10	22	18	G 1/2	56	12.7	31.75 ⁰ _{-0.05}	35.32 ⁰ _{-0.18}	127 ⁰ _{-0.05}	48	19	7.94 ^{+0.03} ₀	114.5	Conforms to ISO 3019-1	BSP	Metric	
A3HG37-FR14K-J1D	M12	M10	22	18	G 1/2	56	12.7	31.75 ⁰ _{-0.05}	35.32 ⁰ _{-0.18}	127 ⁰ _{-0.05}	48	19	7.94 ^{+0.03} ₀	114.5	Conforms to ISO 3019-1	Rc	Metric	

Load Sensing Port/Pilot Port

Load sensing port is common to that of pilot port (except the height dimension from the center of the pump). Refer to page A-174 for the dimensions of pilot port.

Drain Port

Drain port is common to that of pressure compensator model. Refer to page A-163 or A-164 for the dimensions of drain port.

Foot Mtg.:A3HG37-LR14K-E1C/E2C/U1C/U2C/J1C, A3HG37-LR14K-E1D/E2D/U1D/U2D/J1D

Mounting bracket is common to that of pressure compensator model (except max. height dimension). Refer to pages A-163 and A-164 for the dimensions of mounting bracket.

Flange Mtg. Two Bolts:A3HG56-FR14K-E1C/E2C/U1C/U2C/J1C

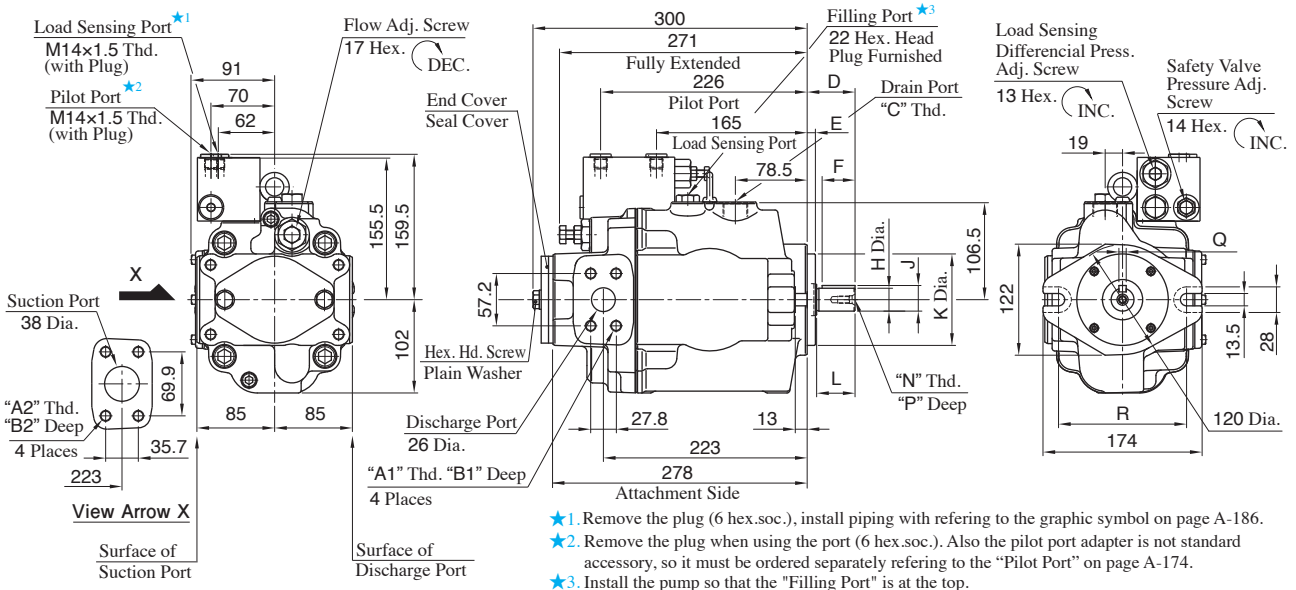

- ★1. Remove the plug (6 hex.soc.), install piping with referring to the graphic symbol on page A-186.
- ★2. Remove the plug when using the port (6 hex.soc.). Also the pilot port adapter is not standard accessory, so it must be ordered separately referring to the "Pilot Port" on page A-174.
- ★3. Install the pump so that the "Filling Port" is at the top.

Model Numbers	A1	A2	B1	B2	C	D	E	F	H	J	K	L	N	P	Q	R	Mounting Flange	Connecting Port	Pipe Flange Threads
A3HG56-FR14K-E1C/E2C	M12	M12	22	22	M27X2	52	9	36	25 ^{+0.009} _{-0.004}	28 ^{+0.009} _{-0.294}	100 ⁰ _{0.054}	42	M8	19	8 ⁰ _{-0.036}	140	Conforms to ISO 3019-2	Metric	Metric
A3HG56-FR14K-U1C	7/16-14 UNC	1/2-13 UNC	20	21	G 3/4	46	9.7	32	25.4 ⁰ _{-0.05}	28.18 ⁰ _{-0.18}	101.6 ⁰ _{-0.05}	38	1/4-20 UNC	16	6.35 ^{+0.03} ₀	146	Conforms to ISO 3019-1	Unified	Unified
A3HG56-FR14K-U2C	M12	M12	22	22	G 3/4	46	9.7	32	25.4 ⁰ _{-0.05}	28.18 ⁰ _{-0.18}	101.6 ⁰ _{-0.05}	38	16	6.35 ^{+0.03} ₀	146	Conforms to ISO 3019-1	BSPP	Metric	
A3HG56-FR14K-J1C	M12	M12	22	22	G 3/4	46	9.7	32	25.4 ⁰ _{-0.05}	28.18 ⁰ _{-0.18}	101.6 ⁰ _{-0.05}	38	16	6.35 ^{+0.03} ₀	146	Conforms to ISO 3019-1	Rc	Metric	

Flange Mtg. Four Bolts:A3HG56-FR14K-E1D/E2D/U1D/U2D/J1D

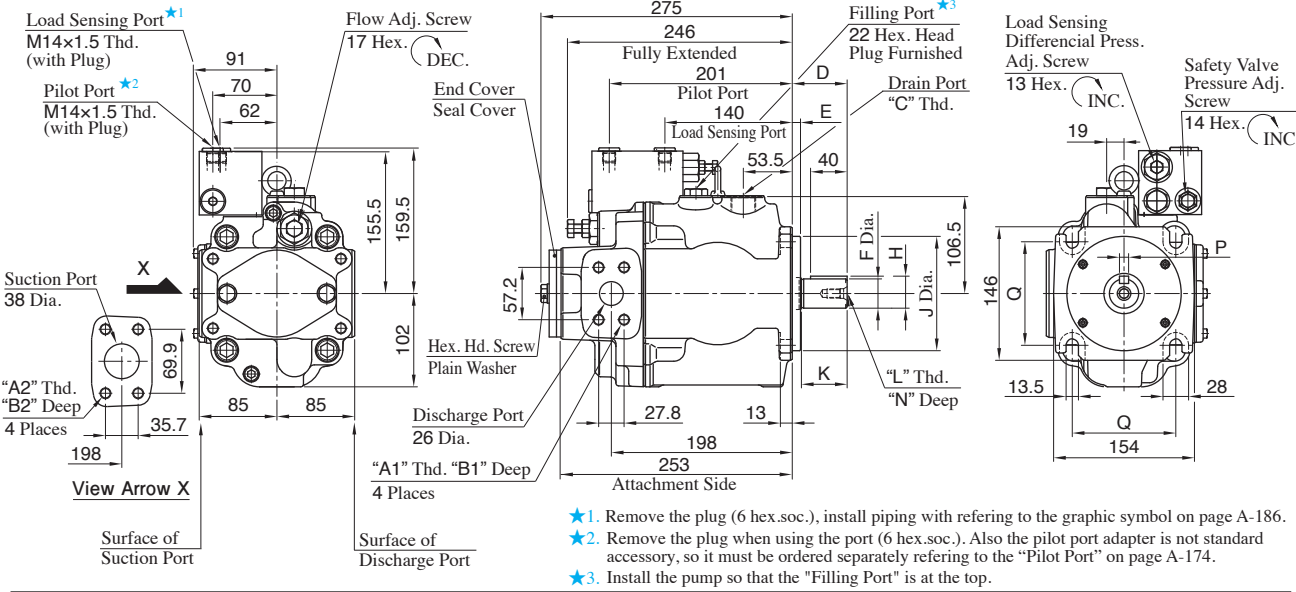

- ★1. Remove the plug (6 hex.soc.), install piping with referring to the graphic symbol on page A-186.
- ★2. Remove the plug when using the port (6 hex.soc.). Also the pilot port adapter is not standard accessory, so it must be ordered separately referring to the "Pilot Port" on page A-174.
- ★3. Install the pump so that the "Filling Port" is at the top.

Model Numbers	A1	A2	B1	B2	C	D	E	F	H	J	K	L	N	P	Q	Mounting Flange	Connecting Port	Pipe Flange Threads
A3HG56-FR14K-E1D/E2D	M12	M12	22	22	M27X2	60	9	32 ^{+0.018} _{+0.002}	35 ^{+0.018} _{-0.288}	125 ⁰ _{-0.063}	50	M10	22	10 ⁰ _{-0.036}	113.2	Conforms to ISO 3019-2	Metric	Metric
A3HG56-FR14K-U1D	7/16-14 UNC	1/2-13 UNC	20	21	G 3/4	56	12.7	31.75 ⁰ _{-0.05}	35.32 ⁰ _{-0.18}	127 ⁰ _{-0.05}	48	19	7.94 ^{+0.03} ₀	114.5	Conforms to ISO 3019-1	Unified	Unified	
A3HG56-FR14K-U2D	M12	M12	22	22	G 3/4	56	12.7	31.75 ⁰ _{-0.05}	35.32 ⁰ _{-0.18}	127 ⁰ _{-0.05}	48	5/16-18 UNC	19	7.94 ^{+0.03} ₀	114.5	Conforms to ISO 3019-1	BSPP	Metric
A3HG56-FR14K-J1D	M12	M12	22	22	G 3/4	56	12.7	31.75 ⁰ _{-0.05}	35.32 ⁰ _{-0.18}	127 ⁰ _{-0.05}	48	19	7.94 ^{+0.03} ₀	114.5	Conforms to ISO 3019-1	Rc	Metric	

Load Sensing Port/Pilot Port

Load sensing port is common to that of pilot port (except the height dimension from the center of the pump). Refer to page A-174 for the dimensions of pilot port.

Drain Port

Drain port is common to that of pressure compensator model. Refer to page A-165 or A-166 for the dimensions of drain port.

Foot Mtg.:A3HG56-LR14K-E1C/E2C/U1C/U2C/J1C, A3HG56-LR14K-E1D/E2D/U1D/U2D/J1D

Mounting bracket is common to that of pressure compensator model (except max. height dimension). Refer to pages A-165 and A-166 for the dimensions of mounting bracket.

Flange Mtg.:A3HG145-FR14K-E1D/E2D/U1D/U2D/J1D

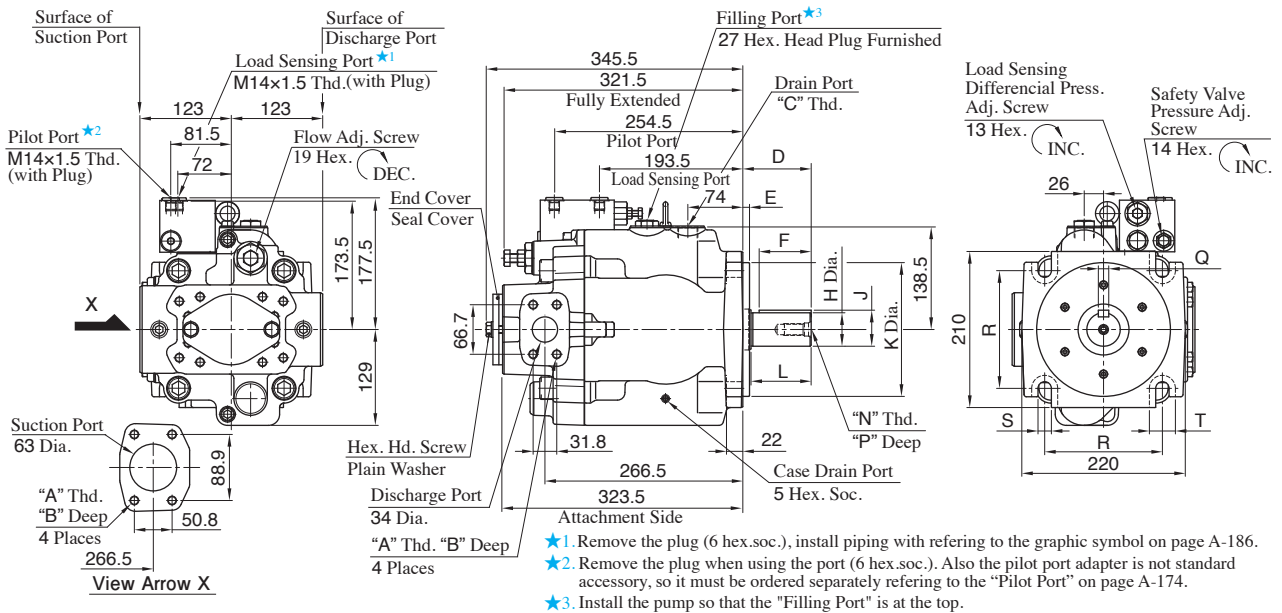

Model Numbers	A	B	C	D	E	F	H	J	K	L	N	P	Q	R	S	T	Mounting Flange	Connecting Port	Pipe Flange Threads
A3HG145-FR14K-E1D/E2D	M12	22	M27×2	92	9	70	45 ^{+0.018} / _{+0.002}	48.5 ^{+0.018} / _{-0.288}	180 ⁰ / _{-0.063}	82	M16	36	14 ⁰ / _{-0.043}	158.4	18	35	Conforms to ISO 3019-2	Metric	Metric
A3HG145-FR14K-U1D	1/2-13 UNC	21	G 3/4	75	12.7	56	44.45 ⁰ / _{-0.05}	49.39 ⁰ / _{-0.18}	152.4 ⁰ / _{-0.05}	67		32	11.11 ^{+0.03} / ₀	161.6	21.5	39	Conforms to ISO 3019-1	Unified	Unified
A3HG145-FR14K-U2D	M12	22	G 3/4	75	12.7	56	44.45 ⁰ / _{-0.05}	49.39 ⁰ / _{-0.18}	152.4 ⁰ / _{-0.05}	67	1/2-13 UNC	32	11.11 ^{+0.03} / ₀	161.6	21.5	39	Conforms to ISO 3019-1	BSPP	Metric
A3HG145-FR14K-J1D	M12	22	G 3/4	75	12.7	56	44.45 ⁰ / _{-0.05}	49.39 ⁰ / _{-0.18}	152.4 ⁰ / _{-0.05}	67		32	11.11 ^{+0.03} / ₀	161.6	21.5	39	Conforms to ISO 3019-1	Rc	Metric

Flange Mtg.:A3HG180-FR14K-E1D/E2D/U1D/U2D/J1D

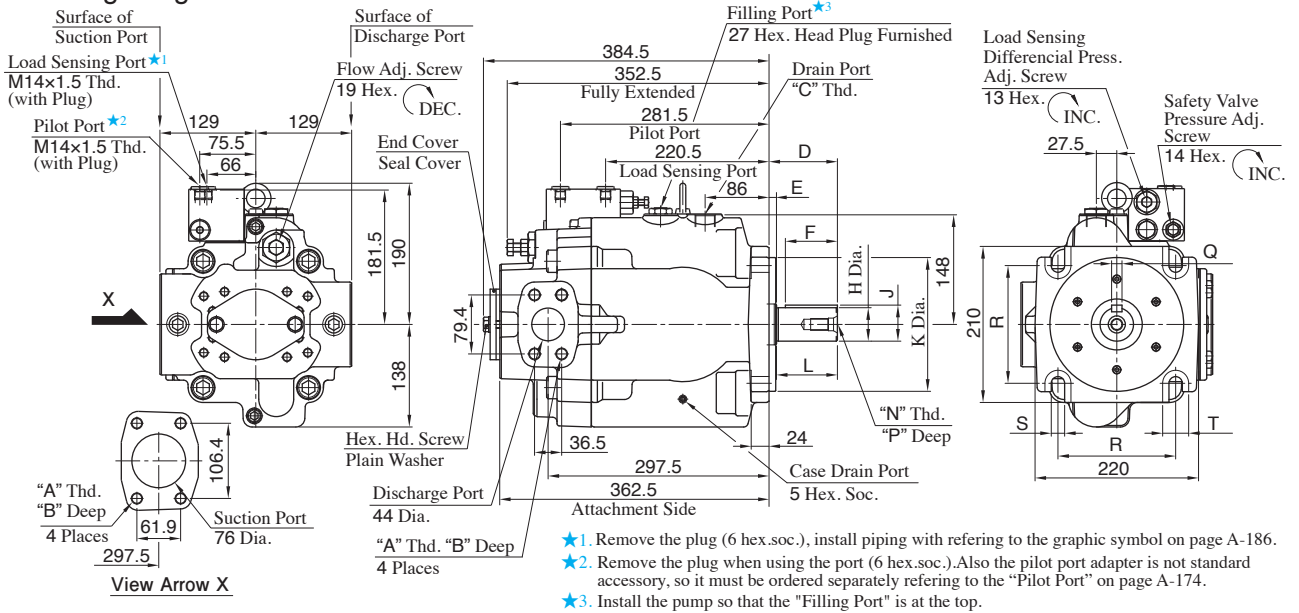

Model Numbers	A	B	C	D	E	F	H	J	K	L	N	P	Q	R	S	T	Mounting Flange	Connecting Port	Pipe Flange Threads
A3HG180-FR14K-E1D/E2D	M16	29	M27×2	92	9	70	45 ^{+0.018} / _{+0.002}	48.5 ^{+0.018} / _{-0.288}	180 ⁰ / _{-0.063}	82	M16	36	14 ⁰ / _{-0.043}	158.4	18	35	Conforms to ISO 3019-2	Metric	Metric
A3HG180-FR14K-U1D	5/8-11 UNC	29	G 3/4	75	12.7	56	44.45 ⁰ / _{-0.05}	49.39 ⁰ / _{-0.18}	152.4 ⁰ / _{-0.05}	67		32	11.11 ^{+0.03} / ₀	161.6	21.5	39	Conforms to ISO 3019-1	Unified	Unified
A3HG180-FR14K-U2D	M16	29	G 3/4	75	12.7	56	44.45 ⁰ / _{-0.05}	49.39 ⁰ / _{-0.18}	152.4 ⁰ / _{-0.05}	67	1/2-13 UNC	32	11.11 ^{+0.03} / ₀	161.6	21.5	39	Conforms to ISO 3019-1	BSPP	Metric
A3HG180-FR14K-J1D	M16	29	G 3/4	75	12.7	56	44.45 ⁰ / _{-0.05}	49.39 ⁰ / _{-0.18}	152.4 ⁰ / _{-0.05}	67		32	11.11 ^{+0.03} / ₀	161.6	21.5	39	Conforms to ISO 3019-1	Rc	Metric

Load Sensing Port/Pilot Port

Load sensing port is common to that of pilot port (except the height dimension from the center of the pump). Refer to page A-174 for the dimensions of pilot port.

Drain Port

Drain port is common to that of pressure compensator model. Refer to page A-169 or A-170 for the dimensions of drain port.

Foot Mtg.:A3HG145-LR14K-E1D/E2D/U1D/U2D/J1D, A3HG180-LR14K-E1D/E2D/U1D/U2D/J1D

Mounting bracket is common to that of pressure compensator model. Refer to pages A-169 and A-170 for the dimensions of mounting bracket.

Mounting Interchangeability between Current and New Models

Load sensing type A3HG series piston pumps were remodeled to enhance the reliability of the products.

Major Changes

Control valves were changed.

Design Number

Design Number 10 → Design Number 11

Mounting Interchangeability

Not interchangeable

The mounting positions for a load sensing port and a pilot port are changed. See the following page for details.

Performance (Example : A3HG71)

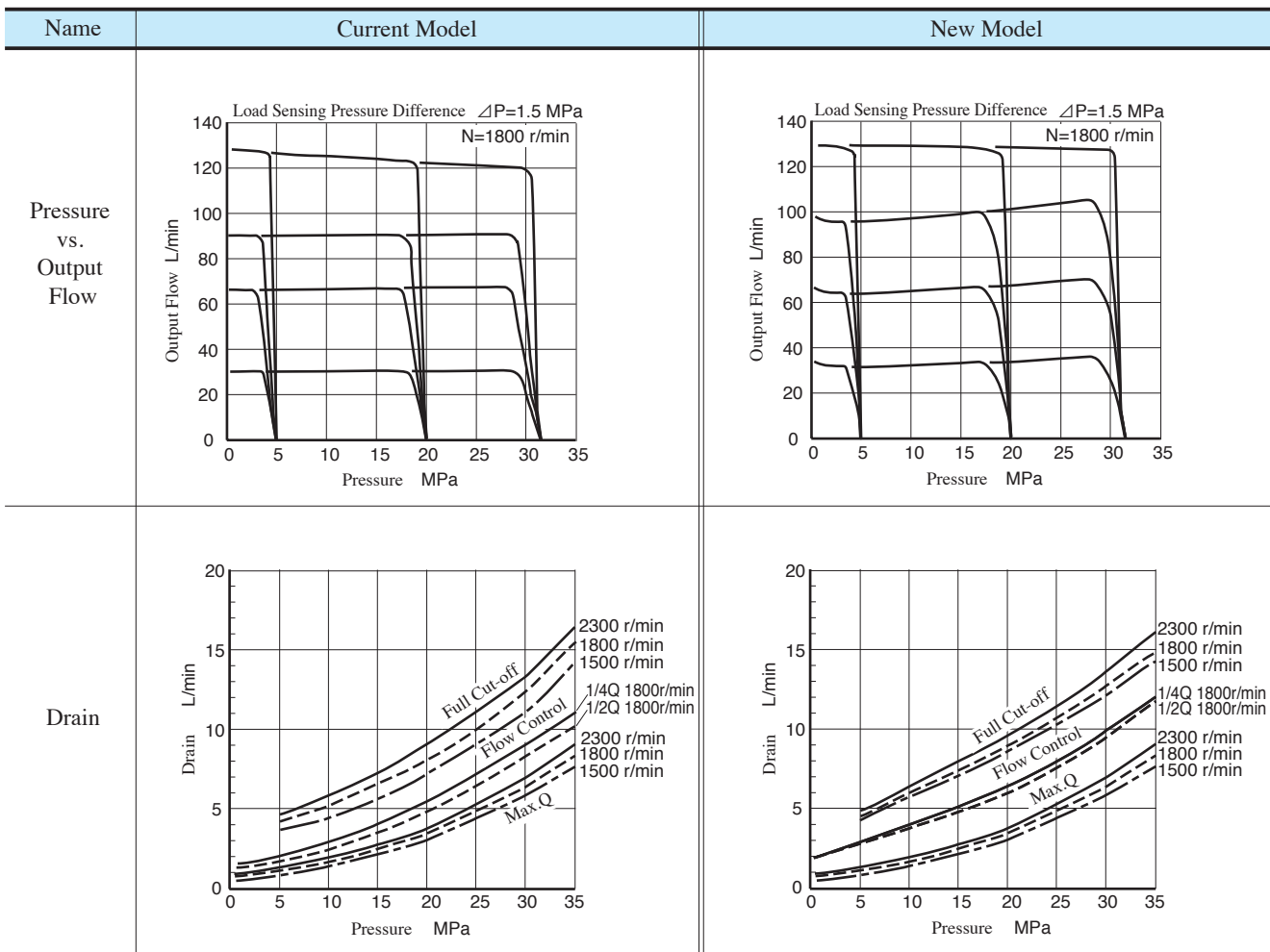

● Dimensions

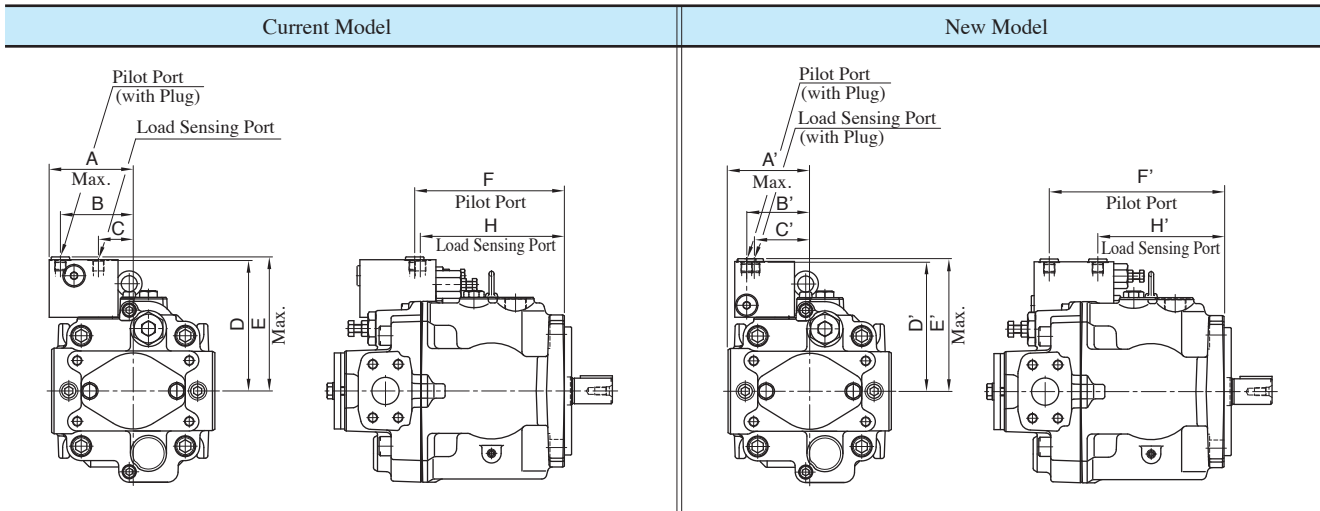

Current Model								New Model							
Model Numbers	A	B	C	D	E	F	H	Model Numbers	A'	B'	C'	D'	E'	F'	H'
A3HG16-*R14*-*C-10	89.5	75.5	31.5	142	146	138.5	131.5	A3HG16-*R14*-*C-11	80.5	65.5	57.5	140	144	171	110
A3HG37-*R14*-*C-10	91	77	33	146.5	150.5	171	164	A3HG37-*R14*-*C-11	85	67	59	144.5	148.5	203.5	142.5
A3HG37-*R14*-*D-10	91	77	33	146.5	150.5	156.5	149.5	A3HG37-*R14*-*D-11	85	67	59	144.5	148.5	189	128
A3HG56-*R14*-*C-10	94	80	36	157.5	161.5	193.5	186.5	A3HG56-*R14*-*C-11	91	70	62	155.5	159.5	226	165
A3HG56-*R14*-*D-10	94	80	36	157.5	161.5	168.5	161.5	A3HG56-*R14*-*D-11	91	70	62	155.5	159.5	201	140
A3HG71-*R14*-*D-10	105	91	43.5	163.5	167.5	187	180	A3HG71-*R14*-*D-11	102	79	69.5	161.5	165.5	219	158
A3HG100-*R14*-*D-10	112.5	90	42.5	169	173	199	192	A3HG100-*R14*-*D-11	112.5	78	68.5	167	171	231	170
A3HG145-*R14*-*D-10	123	93.5	46	175.5	179.5	222.5	215.5	A3HG145-*R14*-*D-11	123	81.5	72	173.5	177.5	254.5	193.5
A3HG180-*R14*-*D-10	129	87.5	40	183.5	190	249.5	242.5	A3HG180-*R14*-*D-11	129	75.5	66	181.5	190	281.5	220.5

● Graphic Symbols

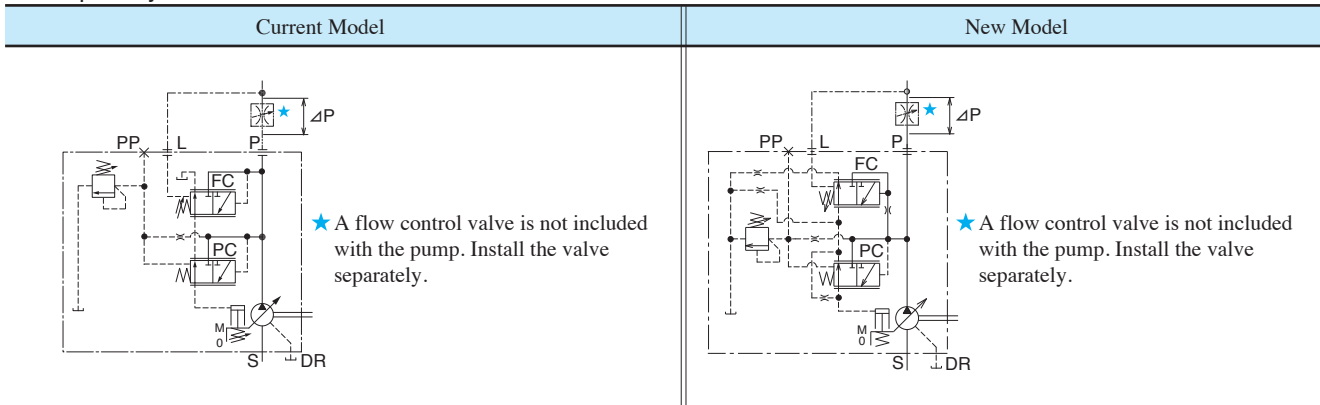

Splined Shaft End

● Flange Mtg.:A3HG *-FR** SP

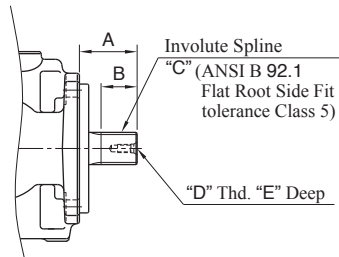

● Flange Mtg.:A3HG *-FR** SP1

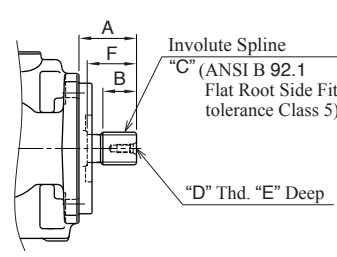

● Foot Mtg.:A3HG *-LR** SP*

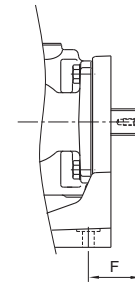

Model Numbers	A	B	C	D	E	F*
A3HG16-FR**SP-*C	38	19.5	11T-16/32DP	1/4-20 UNC	14	—
A3HG16-FR**SP1-*C	38	17.8	11T-16/32DP	1/4-20 UNC	14	30
A3HG37-FR**SP-*C	46	25	15T-16/32DP	1/4-20 UNC	16	—
A3HG37-FR**SP1-*C	46	23.2	15T-16/32DP	1/4-20 UNC	16	38
A3HG37-FR**SP-*D	56	35	14T-12/24DP	5/16-18 UNC	19	—
A3HG37-FR**SP1-*D	56	32.7	14T-12/24DP	5/16-18 UNC	19	48
A3HG56-FR**SP-*C	46	25	15T-16/32DP	1/4-20 UNC	16	—
A3HG56-FR**SP1-*C	46	23.2	15T-16/32DP	1/4-20 UNC	16	38
A3HG56-FR**SP-*D	56	35	14T-12/24DP	5/16-18 UNC	19	—
A3HG56-FR**SP1-*D	56	32.7	14T-12/24DP	5/16-18 UNC	19	48
A3HG71-FR**SP-*D	56	35	14T-12/24DP	5/16-18 UNC	19	—
A3HG71-FR**SP1-*D	56	32.7	14T-12/24DP	5/16-18 UNC	19	48
A3HG100-FR**SP-*D	62	38	17T-12/24DP	7/16-14 UNC	28	—
A3HG100-FR**SP1-*D	62	35.7	17T-12/24DP	7/16-14 UNC	28	54
A3HG145-FR**SP-*D	75	45	13T-8/16DP	1/2-13 UNC	32	—
A3HG145-FR**SP1-*D	75	41.7	13T-8/16DP	1/2-13 UNC	32	67
A3HG180-FR**SP-*D	75	45	13T-8/16DP	1/2-13 UNC	32	—
A3HG180-FR**SP1-*D	75	41.7	13T-8/16DP	1/2-13 UNC	32	67

*Frang/Port code:U1C/U2C/J1C or U1D/U2D/J1D

Model Numbers	F
A3HG16-LR**SP**-*C	35
A3HG37-LR**SP**-*C	38
A3HG37-LR**SP**-*D	61
A3HG56-LR**SP**-*C	38
A3HG56-LR**SP**-*D	61
A3HG71-LR**SP**-*E1D	69
A3HG71-LR**SP**-*U1D/U2D/J1D	61
A3HG100-LR**SP**-*D	75
A3HG145-LR**SP**-*D	28
A3HG180-LR**SP**-*D	28

● For other dimensions, refer to "Flange Mtg.".

Second Pump

The through drive system allows a main pump to be used as a double pump with a connected second pump.

● Connecting pump

1. Remove the end cover and seal cover.
2. Insert the O-ring, which is the attachment of seal cover, to the second pump of spigot joint part of boss.
3. Prepare the coupling and adapter (flange) separately and joint the second pump.

For the ISO 3019-1 pump mount flange, through drive kits with components required to connect a second pump, such as couplings and adapters (flanges), are available. For more details, refer to page A-197.

● Allowable Input Torque

The maximum torque of pumps is limited by shaft and coupling assembly strength. When determining the second pump type, the value of the torque for a particular pump should not exceed the value shown in the table below.

Model Numbers	Number of Pump Mtg. Bolts	(1)Allowable Input Torque T ₁ +T ₂ Nm	(2)Second pump input torque T ₂ Nm
A3HG16-*R**K-E1C	two	94 or less	87 or less
A3HG16-*R**K-U1C/U2C/J1C		135 or less	
A3HG16-*R**SP**-*C		136 or less	
A3HG37/56-*R**K-E1C/E2C	two	279 or less	—
A3HG37-*R**K-U1C/U2C/J1C		263 or less	
A3HG56-*R**K-U1C/U2C/J1C		364 or less	
A3HG37/56-*R**SP**-*C	four	451 or less	297 or less
A3HG37/56/71-*R**K-E1D/E2D		528 or less	
A3HG37-*R**K-U1D/U2D/J1D		801 or less	
A3HG56-*R**K-U1D/U2D/J1D	four	783 or less	609 or less
A3HG71-*R**K-U1D/U2D/J1D		789 or less	
A3HG37/56/71-*R**SP**-*D		852 or less	
A3HG100-*R**K-E1D/E2D	four	1321 or less	609 or less
A3HG100-*R**K-U1D/U2D/J1D		1196 or less	
A3HG100-*R**SP**-*D		1295 or less	
A3HG145/180-*R**K-E1D/E2D	four	1436 or less	609 or less
A3HG145-*R**K-U1D/U2D/J1D		1965 or less	
A3HG180-*R**K-U1D/U2D/J1D		1686 or less	
A3HG145/180-*R**SP**-*D			

- ★1. T₁: Main Pump Input Torque
T₂: Second Pump Input Torque
Torque Formula

$$T = \frac{P \times q}{2\pi} \quad T: \text{Input Torque [Nm]} \quad P: \text{Pressure [MPa]} \quad q: \text{Displacement [cm}^3\text{/rev]}$$

- ★2. For selection of the appropriate pump, both values, (1) and (2), should be satisfied.

A3HG16

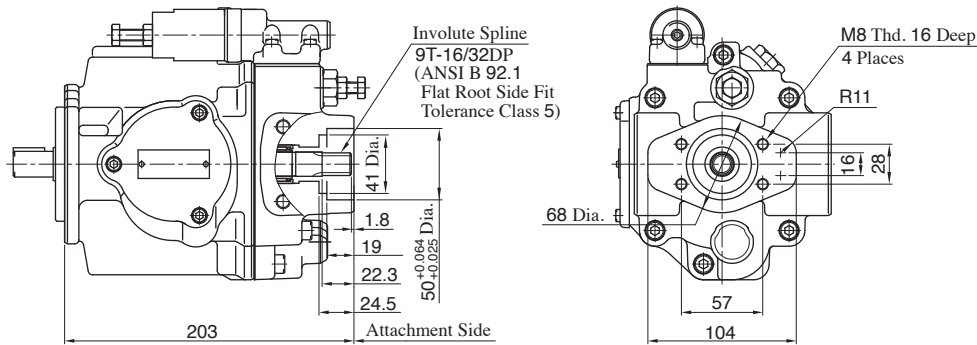

A3HG37/A3HG56

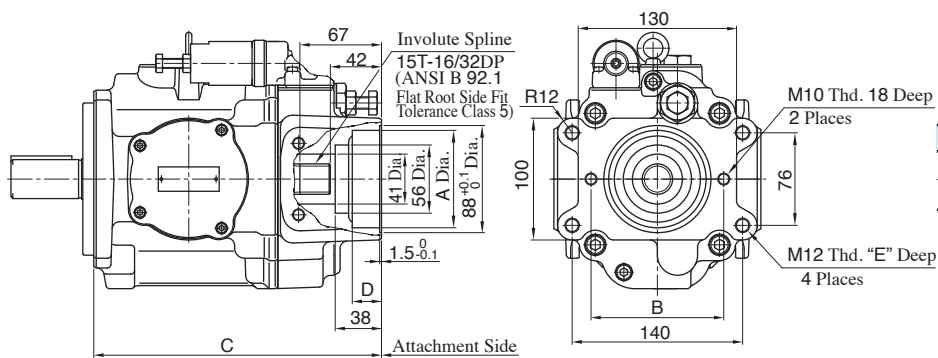

Flange/Port Code	A	B
E1	80 ^{+0.076} Dia. _{+0.030}	109
E2/U1/U2/J1	82.55 ^{+0.090} Dia. _{+0.036}	106

Model Numbers	C	D	E
A3HG37-*R***.*C	251	24	22
A3HG37-*R***.*D	236.5		
A3HG56-*R***.*C	278	28	19
A3HG56-*R***.*D	253		

A3HG71

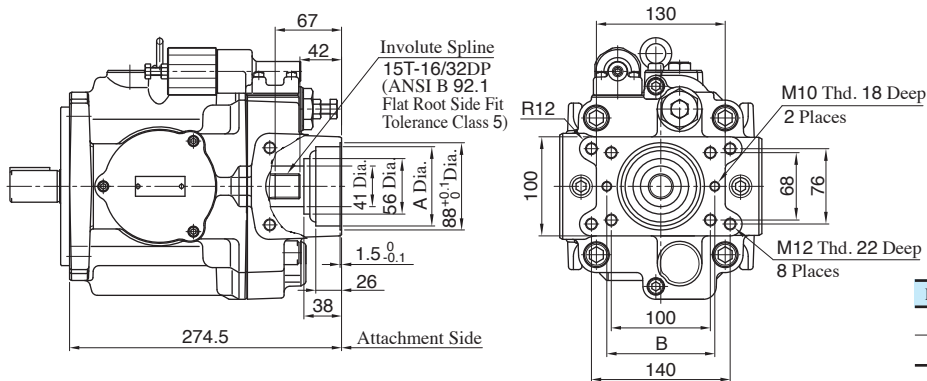

Flange/Port Code	A	B
E1	80 ^{+0.076} Dia. _{+0.030}	109
E2/U1/U2/J1	82.55 ^{+0.090} Dia. _{+0.036}	106

A3HG100/A3HG145/A3HG180

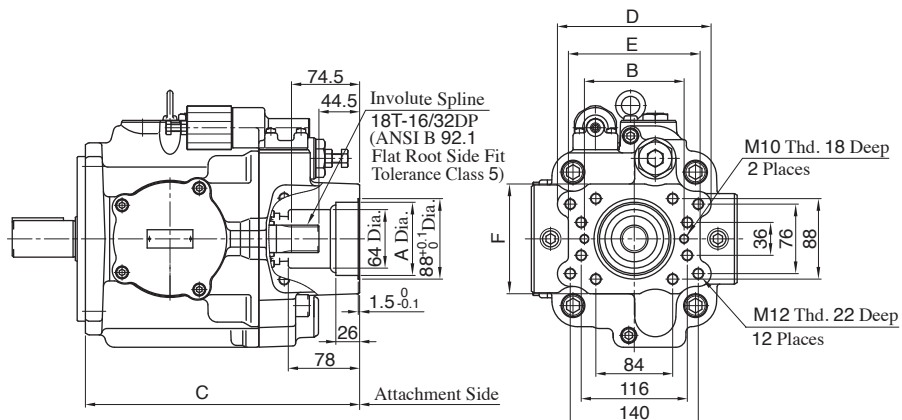

Flange/Port Code	A	B
E1	80 ^{+0.076} Dia. _{+0.030}	109
E2/U1/U2/J1	82.55 ^{+0.090} Dia. _{+0.036}	106

Series Number	C	D	E	F
A3HG100	300	168	144	120
A3HG145	323.5	174	146	120
A3HG180	362.5	174	146	146

Through Drive Kit
Pump Mount Flange

Main Pump and Second Pump Flange/Port Code	Pump Mount Flange
E2/U1/U2/J1	ISO 3019-1

Pump Combination
● Key Type

Main Pump *	A3HG16	A3HG37	A3HG56	A3HG71	A3HG100	A3HG145	A3HG180
Second Pump							
A3HG16-*R**K-E2C/U1C/U2C/J1C	TG1-A-A2-ABK		TG1-B-A2-ABK			TG1-C-A2-ABK	
A3HG37-*R**K-E2C/U1C/U2C/J1C			TG1-B-B2-BBK			TG1-C-B2-BBK	
A3HG37-*R**K-E2D/U1D/U2D/J1D			TG1-B-C4-CK			TG1-C-C4-CK	
A3HG56-*R**K-E2C/U1C/U2C/J1C			TG1-B-B2-BBK			TG1-C-B2-BBK	
A3HG56-*R**K-E2D/U1D/U2D/J1D			TG1-B-C4-CK			TG1-C-C4-CK	
A3HG71-*R**K-E2D/U1D/U2D/J1D				TG1-B-C4-CK		TG1-C-C4-CK	
A3HG100-*R**K-E2D/U1D/U2D/J1D						TG1-C-D4-CCK	
A3HG145-*R**K-E2D/U1D/U2D/J1D						TG1-C-D4-DK	
A3HG180-*R**K-E2D/U1D/U2D/J1D							TG1-C-D4-DK

★ Flange/Port Code:E2/U1/U2/J1

● Spline Type

Main Pump *	A3HG16	A3HG37	A3HG56	A3HG71	A3HG100	A3HG145	A3HG180
Second Pump							
A3HG16-*R**SP*E2C/U1C/U2C/J1C	TG1-A-A2-ABSP		TG1-B-A2-ABSP			TG1-C-A2-ABSP	
A3HG37-*R**SP*E2C/U1C/U2C/J1C			TG1-B-B2-BBSP			TG1-C-B2-BBSP	
A3HG37-*R**SP*E2D/U1D/U2D/J1D			TG1-B-C4-CSP			TG1-C-C4-CSP	
A3HG56-*R**SP*E2C/U1C/U2C/J1C			TG1-B-B2-BBSP			TG1-C-B2-BBSP	
A3HG56-*R**SP*E2D/U1D/U2D/J1D			TG1-B-C4-CSP			TG1-C-C4-CSP	
A3HG71-*R**SP*E2D/U1D/U2D/J1D				TG1-B-C4-CSP		TG1-C-C4-CSP	
A3HG100-*R**SP*E2D/U1D/U2D/J1D						TG1-C-D4-CCSP	
A3HG145-*R**SP*E2D/U1D/U2D/J1D						TG1-C-D4-DSP	
A3HG180-*R**SP*E2D/U1D/U2D/J1D							TG1-C-D4-DSP

★ Flange/Port Code:E2/U1/U2/J1

Model Number Designation

TG1	-A	-A	2	-A	K	-10
Series Number	Main Pump	Second Pump Mtg. Flange ISO Code (ISO 3019-1)	Second Pump Number of Mtg. Bolts	Second Pump Shaft End ISO Code (ISO 3019-1)	Second Pump Shaft Extension	Design Number
TG1	A:A3HG16	A: 82	2:Two	AB: 19	K: Keyed Shaft SP: Splined Shaft	10
	B:	A: 82	2:Two	AB: 19		
	A3HG37-	B: 101	2:Two	BB: 25		
	A3HG71	C: 127	4:Four	C: 32		
	C:	A: 82	2:Two	AB: 19		
	A3HG100-	B: 101	2:Two	BB: 25		
A3HG180	C: 127	4:Four	C: 32			
		D: 152	4:Four	D: 44		

Connecting Pump
● Key Type

TG1-A-A2-ABK

- (1) Mount the gasket and flange to the main pump, and fix it with hexagon socket head cap screws.
Tightening Torque : 30.9 - 37.7 Nm
- (2) Insert the coupling into the shaft end of the second pump, position the coupling at a point where it reaches the shaft end, as shown in the figure below, and then fix the coupling with hexagon socket set screws.
Tightening Torque : 1.50 - 1.84 Nm
- (3) Apply lithium grease to the O-ring, and insert the O-ring into the male spigot of the second pump (see the figure right).
- (4) Prepare M10 hexagon head bolts (hardness classification: 10.9) and plain washers (hardness classification: 22H Hv 220-300).
Mount the second pump to the flange with the bolts and washers.

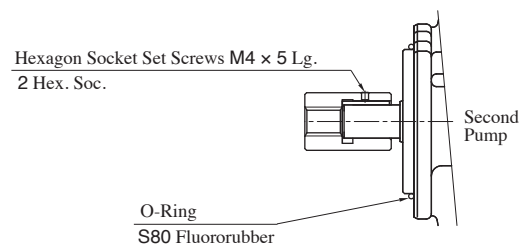

TG1-B-A2-ABK, TG1-C-A2-ABK

- (1) Mount the coupling to the shaft end of the second pump, position the coupling at a point where the coupling shaft end reaches the stepped portion of the second pump shaft, as shown in the figure below, and then fix the coupling with hexagon socket set screws.
Tightening Torque : 1.50 - 1.84 Nm
- (2) Apply lithium grease to the S80 O-ring, and insert the O-ring into the male spigot of the flange.
- (3) Prepare M10 hexagon head bolts (hardness classification: 10.9) and plain washers (hardness classification: 22H Hv 220-300).
Mount the second pump to main pump with the bolts and washers.

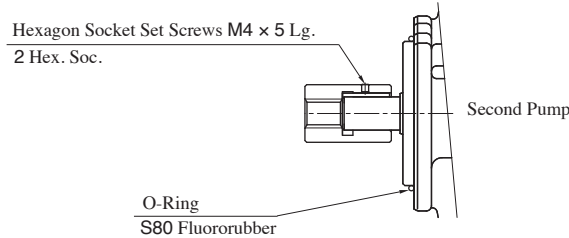

TG1-B-B2-BBK, TG1-B-C4-CK, TG1-C-B2-BBK, TG1-C-C4-CK

- (1) Apply lithium grease to the S80 O-ring, and insert the O-ring into the male spigot of the flange. Mount the flange to the main pump with hexagon socket head cap screws.
Tightening Torque : 104 - 127 Nm
- (2) Insert the coupling into the shaft end of the second pump, position the coupling at a point where it reaches the shaft end, as shown in the figure below, and then fix the coupling with hexagon socket set screws.
Tightening Torque : 5.31 - 6.49 Nm
- (3) Apply lithium grease to the O-ring, and insert the O-ring into the male spigot of the second pump (see the figure below).
- (4) Prepare M12 hexagon head bolts (hardness classification: 10.9) and plain washers (hardness classification: 22H Hv 220-300).
Mount the second pump to the flange with the bolts and washers.

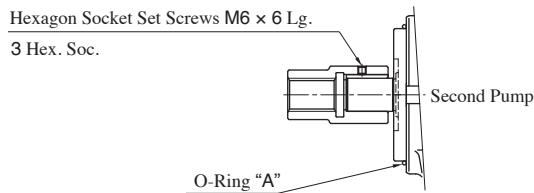

Model Numbers	O-Ring "A"
TG1-B-B2-BBK	S100 Fluororubber
TG1-C-B2-BBK	
TG1-B-C4-CK	S125 Fluororubber
TG1-C-C4-CK	

TG1-C-D4-CCK, TG1-C-D4-DK

- (1) Mount the P16 O-ring to the O-ring groove on the reverse side of the flange (see the figure below).
- (2) Apply lithium grease to the S80 O-ring, and insert the O-ring into the male spigot of the flange. Mount the flange to the main pump with hexagon socket head cap screws.
Tightening Torque : 104 - 127 Nm
- (3) Insert the coupling into the shaft end of the second pump, position the coupling at a point where it reaches the shaft end, as shown in the figure below, and then fix the coupling with hexagon socket set screws.
Tightening Torque : 5.31 - 6.49 Nm
- (4) Apply lithium grease to the G160 O-ring, and mount the O-ring to the O-ring groove on the flange.
- (5) Prepare M20 hexagon head bolts (hardness classification: 10.9) and plain washers (hardness classification: 22H Hv 220-300).
Mount the second pump to the flange with the bolts and washers.

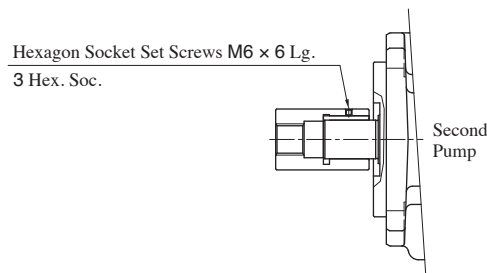
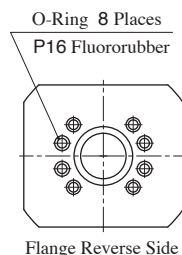

● Spline Type

TG1-A-A2-ABSP

- (1) Mount the gasket and flange to the main pump, and fix it with hexagon socket head cap screws.
Tightening Torque : 30.9 - 37.7 Nm
- (2) Mount the coupling to the shaft end of the second pump or the main pump.
- (3) Apply lithium grease to the S80 O-ring, and insert the O-ring into the male spigot of the second pump (see the figure below).
- (4) Prepare M10 hexagon head bolts (hardness classification: 10.9) and plain washers (hardness classification: 22H Hv 220-300).
Mount the second pump to the flange with the bolts and washers.

TG1-B-A2-ABSP, TG1-C-A2-ABSP

- (1) Mount the coupling to the shaft end of the second pump or the main pump.
- (2) Apply lithium grease to the S80 O-ring, and insert the O-ring into the male spigot of the second pump (see the figure below).
- (3) Prepare M10 hexagon head bolts (hardness classification: 10.9) and plain washers (hardness classification: 22H Hv 220-300).
Mount the second pump to the main pump with the bolts and washers.

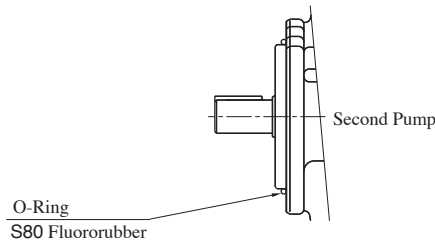

TG1-B-B2-BBSP, TG1-B-C4-CSP, TG1-C-B2-BBSP, TG1-C-C4-CSP

- (1) Apply lithium grease to the S80 O-ring, and insert the O-ring into the male spigot of the flange. Mount the flange to the main pump with hexagon socket head cap screws.
Tightening Torque : 104 - 127 Nm
- (2) Mount the coupling to the shaft end of the second pump or the main pump.
- (3) Apply lithium grease to the O-ring, and insert the O-ring into the male spigot of the second pump (see the figure below).
- (4) Prepare M12 hexagon head bolts (hardness classification: 10.9) and plain washers (hardness classification: 22H Hv 220-300).
Mount the second pump to the flange with the bolts and washers.

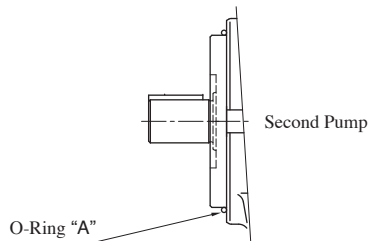

Model Numbers	O-Ring "A"
TG1-B-B2-BBSP	S100 Fluororubber
TG1-C-B2-BBSP	
TG1-B-C4-CSP	S125 Fluororubber
TG1-C-C4-CSP	

TG1-C-D4-CCSP, TG1-C-D4-DSP

- (1) Mount the P16 O-ring to the O-ring groove on the reverse side of the flange (see the figure below).
- (2) Apply lithium grease to the S80 O-ring, and insert the O-ring into the male spigot of the flange. Mount the flange to the main pump with hexagon socket head cap screws.
Tightening Torque : 104 - 127 Nm
- (3) Mount the coupling to the shaft end of the second pump or the main pump.
- (4) Apply lithium grease to the G160 O-ring, and mount the O-ring to the O-ring groove on the flange.
- (5) Prepare M20 hexagon head bolts (hardness classification: 10.9) and plain washers (hardness classification: 22H Hv 220-300).
Mount the second pump to the flange with the bolts and washers.

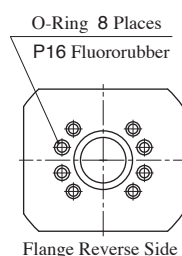

TG1-A-A2-ABK

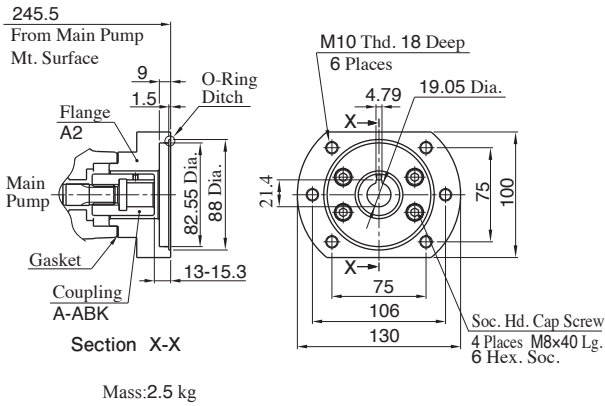

TG1-A-A2-ABSP

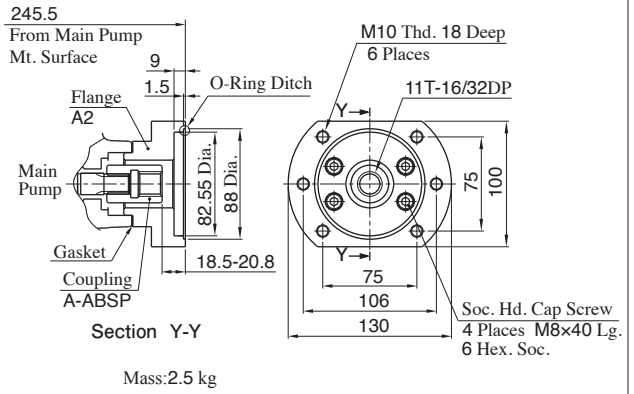

TG1-B-A2-ABK/TG1-C-A2-ABK

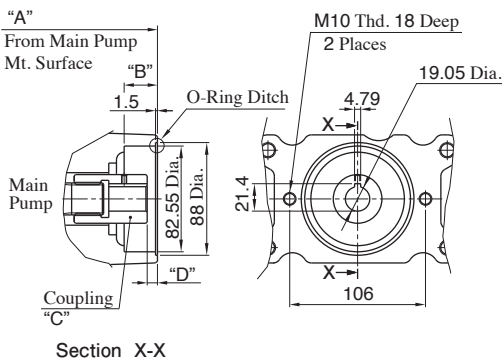

TG1-B-A2-ABSP/TG1-C-A2-ABSP

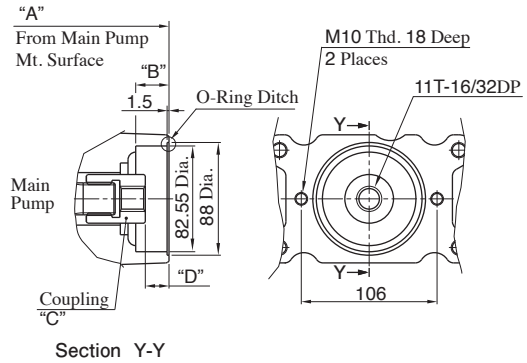

Through Drive Kit	Main Pump	A	B	C	D	Mass kg
TG1-B-A2-ABK	A3HG37-*R**K-E2C/U1C/U2C/J1C	251	24	B-ABK	8-10	0.3
	A3HG37-*R**K-E2D/U1D/U2D/J1D	236.5				
	A3HG56-*R**K-E2C/U1C/U2C/J1C	278				
	A3HG56-*R**K-E2D/U1D/U2D/J1D	253				
	A3HG71-*R**K-E2D/U1D/U2D/J1D	274.5				
TG1-C-A2-ABK	A3HG100-*R**K-E2D/U1D/U2D/J1D	300	26	C-ABK	8-11.5	0.4
	A3HG145-*R**K-E2D/U1D/U2D/J1D	323.5				
	A3HG180-*R**K-E2D/U1D/U2D/J1D	362.5				

Through Drive Kit	Main Pump	A	B	C	D	Mass kg
TG1-B-A2-ABSP	A3HG37-*R**SP*-E2C/U1C/U2C/J1C	251	24	B-ABSP	18.5-21	0.3
	A3HG37-*R**SP*-E2D/U1D/U2D/J1D	236.5				
	A3HG56-*R**SP*-E2C/U1C/U2C/J1C	278				
	A3HG56-*R**SP*-E2D/U1D/U2D/J1D	253				
	A3HG71-*R**SP*-E2D/U1D/U2D/J1D	274.5				
TG1-C-A2-ABSP	A3HG100-*R**SP*-E2D/U1D/U2D/J1D	300	26	C-ABSP	18.5-20.5	0.4
	A3HG145-*R**SP*-E2D/U1D/U2D/J1D	323.5				
	A3HG180-*R**SP*-E2D/U1D/U2D/J1D	362.5				

TG1-B-B2-BBK/TG1-C-B2-BBK

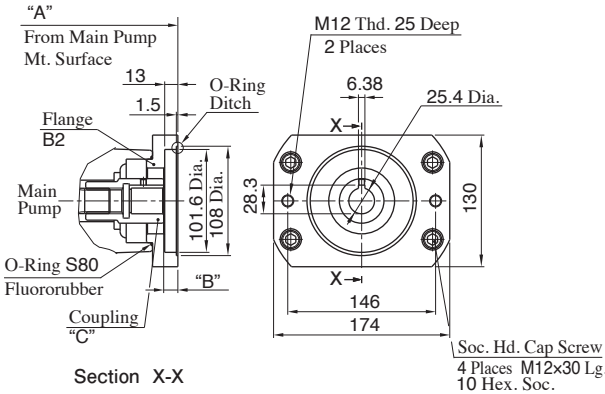

TG1-B-B2-BBSP/TG1-C-B2-BBSP

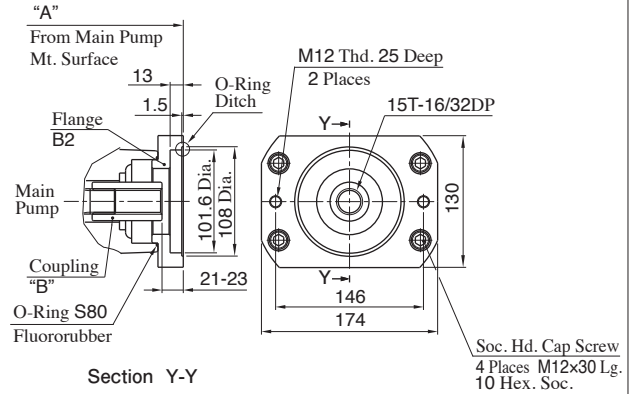

Through Drive Kit	Main Pump	A	B	C	Mass kg
TG1-B-B2-BBK	A3HG37-*R**K-E2C/U1C/U2C/J1C	276	14-15	B-BBK	3.6
	A3HG37-*R**K-E2D/U1D/U2D/J1D	261.5			
	A3HG56-*R**K-E2C/U1C/U2C/J1C	303			
	A3HG56-*R**K-E2D/U1D/U2D/J1D	278			
	A3HG71-*R**K-E2D/U1D/U2D/J1D	299.5			
TG1-C-B2-BBK	A3HG100-*R**K-E2D/U1D/U2D/J1D	325	14-16.5	C-BBK	3.7
	A3HG145-*R**K-E2D/U1D/U2D/J1D	348.5			
	A3HG180-*R**K-E2D/U1D/U2D/J1D	387.5			

Through Drive Kit	Main Pump	A	B	Mass kg
TG1-B-B2-BBSP	A3HG37-*R**SP*-E2C/U1C/U2C/J1C	276	B-BBSP	3.5
	A3HG37-*R**SP*-E2D/U1D/U2D/J1D	261.5		
	A3HG56-*R**SP*-E2C/U1C/U2C/J1C	303		
	A3HG56-*R**SP*-E2D/U1D/U2D/J1D	278		
	A3HG71-*R**SP*-E2D/U1D/U2D/J1D	299.5		
TG1-C-B2-BBSP	A3HG100-*R**SP*-E2D/U1D/U2D/J1D	325	C-BBSP	3.5
	A3HG145-*R**SP*-E2D/U1D/U2D/J1D	348.5		
	A3HG180-*R**SP*-E2D/U1D/U2D/J1D	387.5		

TG1-B-C4-CK/TG1-C-C4-CK

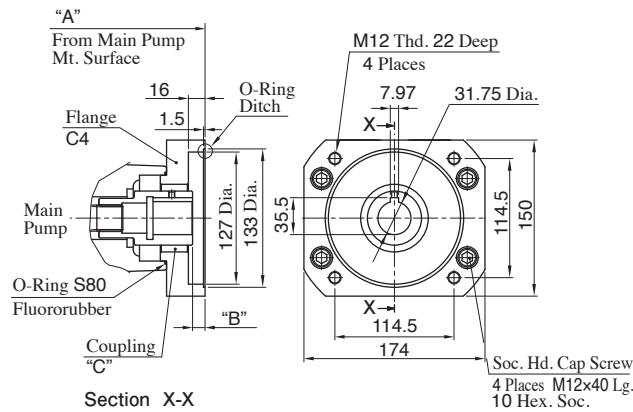

Through Drive Kit	Main Pump	A	B	C	Mass kg
TG1-B-C4-CK	A3HG37-*R**K-E2C/U1C/U2C/J1C	288	12-14	B-CK	5.8
	A3HG37-*R**K-E2D/U1D/U2D/J1D	273.5			
	A3HG56-*R**K-E2C/U1C/U2C/J1C	315			
	A3HG56-*R**K-E2D/U1D/U2D/J1D	290			
TG1-C-C4-CK	A3HG71-*R**K-E2D/U1D/U2D/J1D	311.5	12-14.5	C-CK	6
	A3HG100-*R**K-E2D/U1D/U2D/J1D	337			
	A3HG180-*R**K-E2D/U1D/U2D/J1D	399.5			

TG1-B-C4-CSP/TG1-C-C4-CSP

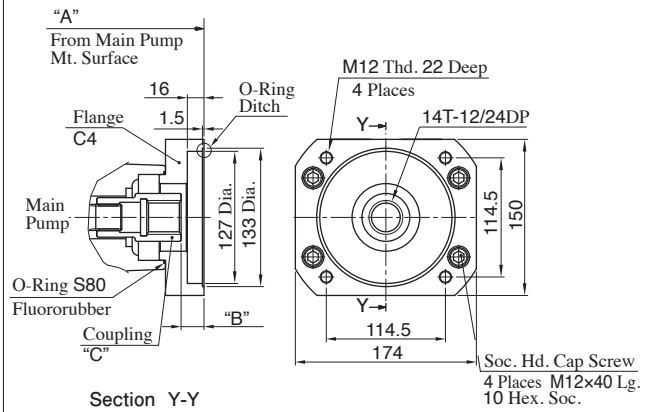

Through Drive Kit	Main Pump	A	B	C	Mass kg
TG1-B-C4-CSP	A3HG37-*R**SP*-E2C/U1C/U2C/J1C	288	21-23	B-CSP	5.6
	A3HG37-*R**SP*-E2D/U1D/U2D/J1D	273.5			
	A3HG56-*R**SP*-E2C/U1C/U2C/J1C	315			
	A3HG56-*R**SP*-E2D/U1D/U2D/J1D	290			
TG1-C-C4-CSP	A3HG71-*R**SP*-E2D/U1D/U2D/J1D	311.5	21-23.5	C-CSP	5.7
	A3HG100-*R**SP*-E2D/U1D/U2D/J1D	337			
	A3HG180-*R**SP*-E2D/U1D/U2D/J1D	399.5			

TG1-C-D4-CCK/TG1-C-D4-DK

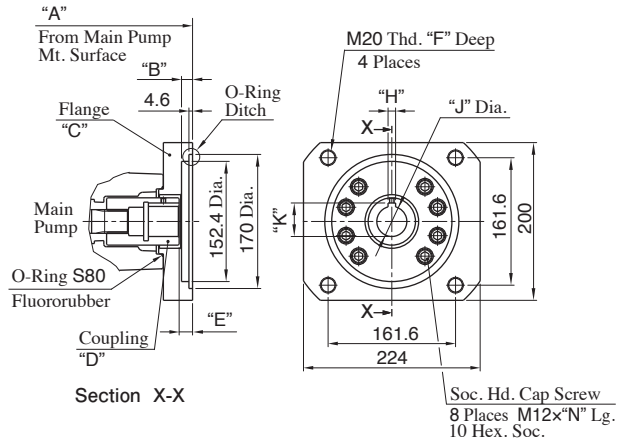

Through Drive Kit	Main Pump	A	B	C
TG1-C-D4-CCK	A3HG100-*R**K-E2D/U1D/U2D/J1D	337	14	D4-1
	A3HG145-*R**K-E2D/U1D/U2D/J1D	360.5		
	A3HG180-*R**K-E2D/U1D/U2D/J1D	399.5		
TG1-C-D4-DK	A3HG145-*R**K-E2D/U1D/U2D/J1D	383.5	15	D4-2
	A3HG180-*R**K-E2D/U1D/U2D/J1D	422.5		

Through Drive Kit	D	E	F	H	J	K	N	Mass kg
TG1-C-D4-CCK	C-CCK	17-19.5	37	9.56	38.1	42.5	30	10.7
TG1-C-D4-DK	C-DK	19-21.5	34	11.14	44.45	49.6	50	16.7

TG1-C-D4-CCSP/TG1-C-D4-DSP

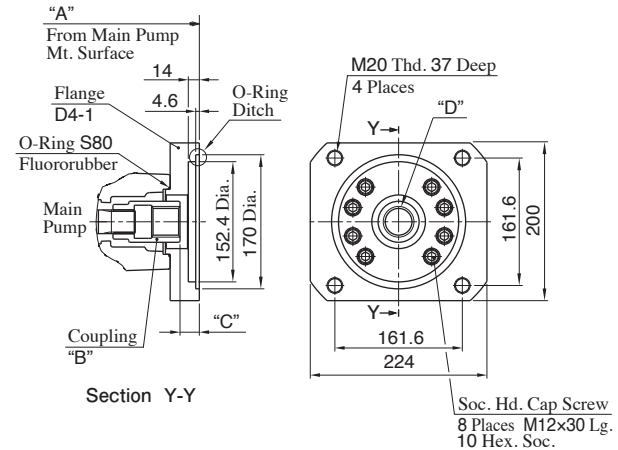



Through Drive Kit	Main Pump	A	B	C
TG1-C-D4-CCSP	A3HG100-*R**SP*-E2D/U1D/U2D/J1D	337	C-CCSP	24-26.5
	A3HG145-*R**SP*-E2D/U1D/U2D/J1D	360.5		
	A3HG180-*R**SP*-E2D/U1D/U2D/J1D	399.5		
TG1-C-D4-DSP	A3HG145-*R**SP*-E2D/U1D/U2D/J1D	360.5	C-DSP	30-32.5
	A3HG180-*R**SP*-E2D/U1D/U2D/J1D	399.5		

Through Drive Kit	D	Mass kg
TG1-C-D4-CCSP	17T-12/24DP	10
TG1-C-D4-DSP	13T-8/16DP	10.2

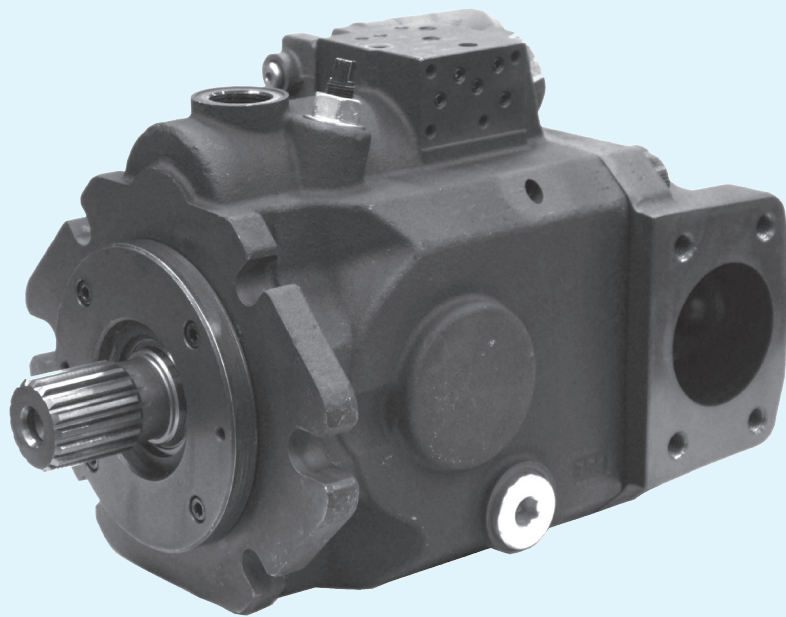
A3HM Series High Pressure Variable Displacement Piston Pumps



"A3HM" Series Variable Displacement Piston Pumps

Pump Type	Graphic Symbol	Geometric Displacement cm ³ /rev								Maximum Operating Pressure MPa	Page		
		1	2	5	10	20	50	100	200			300	
					A3HM18						35	A-203	
					A3HM28								
					A3HM45								
					A3HM63								
					A3HM85								
					A3HM100								

★ Three control methods are available:
 Pressure Compensator Type/Pilot Pressure Control Type Pressure Compensator/Load Sensing Type

● Consult Yuken for "A3HM" Series High Pressure Variable Displacement Piston Pumps details.

A3HM Series Variable Displacement Piston Pumps - Single Pump

"A3HM" series piston for open circuit pumps match the requirements of construction machinery and mobile equipment. Drastically compact and lightweight. Suitable for mobile products.

Features

- Compact and lightweight compared with conventional pumps.
- Applicable for medium pressure hydraulic systems: Rated Pressure 31.5 MPa and Max. Pressure 35 MPa.
- We offer 6 models in the geometric displacement range from 18.6 to 100.7 cm³/rev. Available for a wide range of applications.
- Through-drive type is employed for standard models. Driven side pumps with displacement volume up to the same displacement as that of the driving pump can be connected. Wide range of maximum flow due to it.

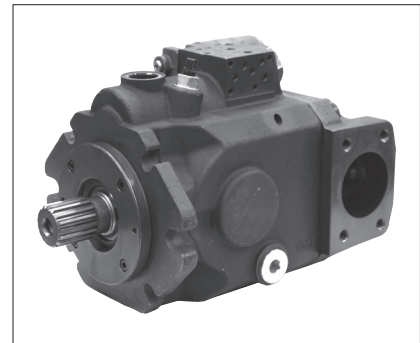

Specifications

Model Numbers		A3HM18	A3HM28	A3HM45	A3HM63	A3HM85	A3HM100
Geometric Displacement	cm ³ /rev	18.6	28.7	45.7	63.5	85.6	100.7
Minimum Adj. Flow	cm ³ /rev	—	17.8	27.5	44.0	61.3	70.5
Rated Pressure	MPa	31.5					
Max. Pressure ^{★1}	MPa	35					
Pressure Adj. Range	MPa	3.0 - 31.5					
Allowable Shaft Speed r/min	Max. ^{★2}	3400	3200 (3600)	2700 (3300)	2600 (2700)	2500 (2700)	2300 (2600)
	Min.	600					
Suction Pressure		-20 kPa - +400 kPa					
Drain Pressure		Normal Pressure : 0.1 MPa or less Surge Pressure : 0.4 MPa or less (Allowable duration for surge pressure 0.1 sec or less)					
Hydraulic Fluid		Petroleum Based Oils ^{★3}					
Seal Material		FKM (Fluoro Rubber)					
Mass ^{★4}		12	14	21	24.5/25	36	36

★1. If operating pressure exceeds the rated pressure due to surge pressure, make sure that it does not exceed the max. pressure. Please contact Yuken for further information.

★2. Minimum flow values are shown in brackets.

★3. Please contact Yuken regarding the use of non-petroleum based oils.

★4. Pressure Compensator Control Type

Control Type

Control Type	Graphic Symbols	Performance Characteristics	Explanation
"01" Pressure Compensator Type			<ul style="list-style-type: none"> ● When the system pressure increases and comes close to the preset cut-off pressure, the pump flow decreases automatically while maintaining the set pressure as it is. ● The output flow and full cut-off pressure can be manually adjusted.
"07" Pilot Pressure Control Type Pressure Compensator			<ul style="list-style-type: none"> ● The pump is used in combination with a pilot relief valve or proportional pressure control valve. ● By controlling the pilot pressure, the full cut-off pressure can be remote-controlled according user requirements.
"14" Load Sensing Type			<ul style="list-style-type: none"> ● This is an energy-saving type control which maintains the pump flow at the absolute minimum necessary level to operate the actuator. ● This type of control automatically regulates the output flow so that the inlet-outlet differential pressure of the flow control valve at the output side is constant.

★1. Flow adjustment function is not available on A3HM18.

★2. Pilot relief valve/ proportional pressure control valve is not supplied with the pump. Please arrange it separately.

★3. Flow control valve is not supplied with the pump. Please arrange it separately.

A7H Series High Pressure Variable Displacement Piston Pumps

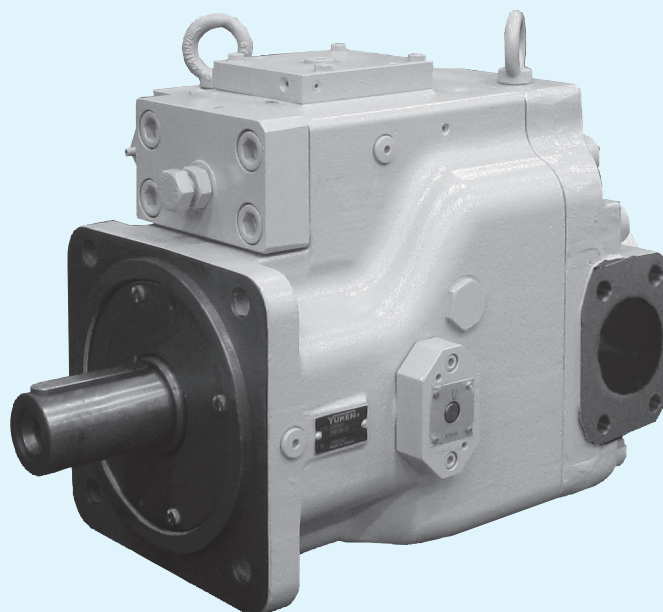

■ “A7H” Series High Pressure Variable Displacement Piston Pumps

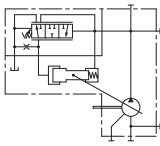
Pump Type	Graphic Symbol	Geometric Displacement cm ³ /rev							Maximum Operating Pressure MPa	Page
		1	2	5	10	20	50	100		
 Series High Pressure Variable Displacement Piston Pumps	Single Pump★ 							A7H180 A7H265	40	A-205

★ The control type has three kinds of Pressure Compensator Type and Constant Power Control Type and Constant Power Control Type with External Pilot.

● Consult Yuken when material such as dimensions figures is required.

AZHT Series High Pressure Variable Displacement Piston Pumps, Pressure Compensator Type

Specifications

Model Numbers	Geometric Displacement cm ³ /rev	Operating Pressure MPa		Shaft Speed Range r/min	
		Rated	Intermittent	Rated	Max.*
A7H180- *R01S* * -11	180	35	40	1800	1900
A7H265- *R01S* * -11	270	35	40	1200	1600

* Max. Allowable Shaft Speed is specified when the suction pressure is -0.01 MPa -.

Model Number Designation

A7H180	-F	R	01	S	N	A	-11
Series Number	Mounting	Direction of Rotation	Control Type	Port Position	Pipe Flange	Outboard Pump Mounting Type	Design Number
A7H180 (180 cm ³ /rev)	F: Flange Mtg.	(Viewed from Shaft End) R: Clockwise	01: Pressure Compensator Type (With Min. Flow Adj. Function)	S: Side Port	None: With Pipe Flange N: Without Pipe Flange	None: Without Mounting (With End Cover) A: SAE A B: SAE B C: SAE C CC: SAE CC D: SAE D	11
A7H265 (270 cm ³ /rev)	L: Foot Mtg.	R: Clockwise					

Graphic Symbol

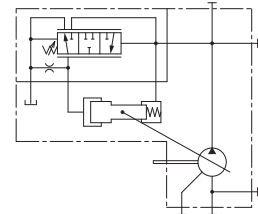

Performance Characteristics

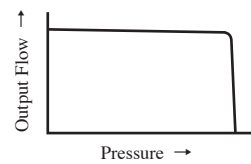

AZHT Series High Pressure Variable Displacement Piston Pumps, Constant Power Control Type

Specifications

Model Numbers	Geometric Displacement cm ³ /rev	Operating Pressure MPa		Shaft Speed Range r/min	
		Rated	Max.*	Rated	Max.*
A7H180- *R09* * * * -11	180	35	40	1800	1900
A7H265- *R09* * * * -11	270	35	40	1200	1600

* Max. Allowable Shaft Speed is specified when the suction pressure is -0.01 MPa -.

Model Number Designation

A7H180	-F	R	09	R	S	N	A	-M1	-11
Series Number	Mounting	Direction of Rotation	Control Type	External Pilot	Port Position	Pipe Flange	Outboard Pump Mounting Type	Code of Constant Power Control Type	Design Number
A7H180 (180 cm ³ /rev)	F: Flange Mtg.	(Viewed from Shaft End) R: Clockwise	09: Constant Power Control Type (With Min. Flow Adj. Function)	None: Without External Pilot R: With External Pilot	S: Side Port	None: With Pipe Flange N: Without Pipe Flange	None: Without Mounting (With End Cover) A: SAE A B: SAE B C: SAE C CC: SAE CC D: SAE D	Refer to Below Code Table	11
A7H265 (270 cm ³ /rev)	L: Foot Mtg.	R: Clockwise							

Graphic Symbols

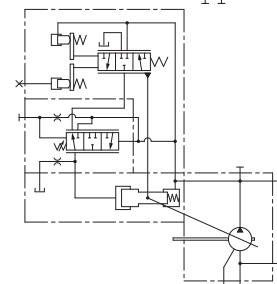
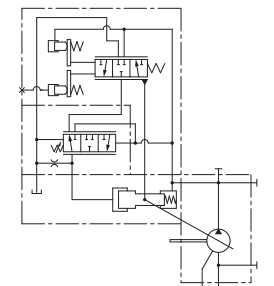

09R (With External Pilot)

Performance Characteristics

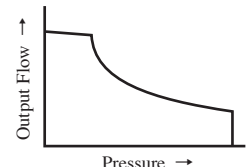

Code Table of Constant Power Control Type

<A7H180>					<A7H265>			
Motor power kW	970 r/min	1150 r/min	1450 r/min	1750 r/min	Motor power kW	970 r/min	1150 r/min	1450 r/min
30	M4	-	-	-	45	M5	-	-
37	M2	M3	-	-	55	M3	M5	-
45	M0	M2	M4	-	75	H3	M1	M4
55	H3	M0	M2	M4	90	H2	H3	M2
75	-	H1	MA	M1	110	-	H1	H4
90	-	-	H2	MA	132	-	-	H2
110	-	-	-	H2				

PAL PUMPS & **M** Series Electric Motors

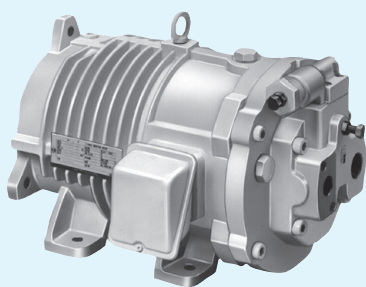

PAL PUMPS

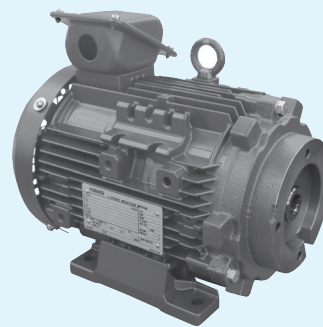

M Series Electric Motors

■ MOTOR-PUMPS

Model Numbers	Graphic Symbol	Geometric Displacement cm ³ /rev						Maximum Operating Pressure MPa	Page		
		1	2	5	10	20	50			100	150
PM10-01B- *-31									7	A-207	
PM10-01C-1.5-31									16		
PM16-01 *- *-30											16
PM22-01 *- *-30											16
PM37-01 *- *-30											16

■ **M** Series Electric Motors A-209

PAL PUMPS, Pressure Compensator Type

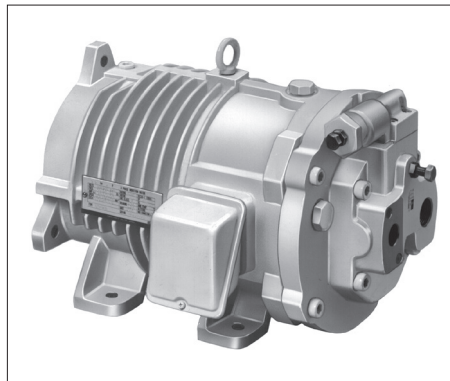

Graphic Symbol

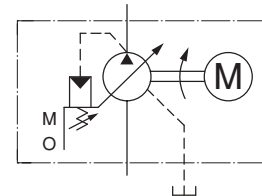

Specifications

Model Numbers	Geometric Displacement cm ³ /rev	Minimum Adj. Flow cm ³ /rev	Operating Pressure ^{★1} MPa	Electric Motor ^{★2} 50 Hz : 200 V AC 60 Hz : 200/220 V AC	Approx Mass. kg
PM10-01B-0.75-31	10.0	2.0	7	0.75 kW × 4P	28.1
PM10-01 * -1.5-31			16	1.5 kW × 4P	41.8
PM16-01 * -1.5-30	15.8	6.0	16	1.5 kW × 4P	39.7
PM16-01 * -2.2-30				2.2 kW × 4P	43.8
PM22-01 * -2.2-30	22.2	8.5	16	2.2 kW × 4P	43.8
PM22-01 * -3.7-30				3.7 kW × 4P	64.2
PM37-01 * -3.7-30	36.9	10	16	3.7 kW × 4P	72.0
PM37-01 * -5.5-30				5.5 kW × 4P	74.0

★1. For pressure adjusting ranges, see the Model Number Designation.

★2. For motors other than those for 200/220 V AC, please contact us.

Model Number Designation

PM16	-01	B	-2.2	-30	
Series Number	Control Type	Pres. Adj. Range MPa	Motor Power	Design Number	
PM10 (10.0 cm ³ /rev)	01 : Pressure Compensator Type	B : 1.2 - 7	0.75 : 0.75 kW × 4P	31	
		B : 1.2 - 7 C : 2 - 16	1.5 : 1.5 kW × 4P		
B : 1.2 - 7 C : 2 - 16		1.5 : 1.5 kW × 4P 2.2 : 2.2 kW × 4P	30		
B : 1.2 - 7 C : 2 - 16		2.2 : 2.2 kW × 4P 3.7 : 3.7 kW × 4P	30		
PM16 (15.8 cm ³ /rev)			B : 1.2 - 7 C : 2 - 16	3.7 : 3.7 kW × 4P 5.5 : 5.5 kW × 4P	30
PM22 (22.2 cm ³ /rev)			B : 1.2 - 7 C : 2 - 16		
PM37 (36.9 cm ³ /rev)		B : 1.2 - 7 C : 2 - 16			

★1. For Two-Pressure Two-Flow Control Type by System Pressure, Two-Pressure Two-Flow Control Type by Solenoid Valve and Pilot Pressure Control Type Pressure Compensator, make inquiries separately.

Ratings of Electric Motor

Model Numbers	Voltage-Frequency V – Hz	Rated Current A	Shaft Speed r/min	Inrush Current A	Ambient Conditions Using
PM10-01B-0.75-31	200 – 50 200 – 60 220 – 60	4.2 3.6 3.6	1400 1690 1710	22.5 21.6 23.8	<ul style="list-style-type: none"> ● Location : Indoor Room ● Ambient Temperature Range : 0 to +40 °C ● Ambient Humidity : 95 % RH or less ● Altitude : 1000 m or less ● To be nothing corrosive and explosive gasses and steam.
PM10-01 * -1.5-31 PM16-01 * -1.5-30	200 – 50 200 – 60 220 – 60	6.4 6.2 5.8	1420 1710 1730	43.6 39.4 43.3	
PM16-01 * -2.2-30 PM22-01 * -2.2-30	200 – 50 200 – 60 220 – 60	9.4 8.8 8.4	1420 1710 1730	63.6 59.1 65.1	
PM22-01 * -3.7-30 PM37-01 * v3.7-30	200 – 50 200 – 60 220 – 60	14.6 14.0 13.0	1430 1730 1740	102.0 86.0 94.6	
PM37-01 * -5.5-30	200 – 50 200 – 60 220 – 60	22.8 21.2 19.8	1430 1720 1730	150.0 130.0 143.0	

Pipe Flange Kits

Flange kits are available. When ordering, specify the kits from the table below. In addition, model PM10 does not use pipe flanges. Detail of pipe flange kit is described on pages A-258 and A-259.

Pump Model Numbers	Name of Port	Pipe Flange Kit Numbers		
		Threaded Connection	Socket Welding Type ^{★1}	Welding Neck Type
PM16/PM22	Suction	F5-06-A-1021 ^{★2}	F5-06-B-1021 ^{★2}	—
	Discharge	—	—	—
PM37	Suction	F5-10-A-10	F5-10-B-10	F5-10-C-10
	Discharge	F5-10-A-10	F5-10-B-10	F5-10-C-10

★1. For the Socket Welding Type F5-06-B-1021 or F5-10-B-10, the operating pressure may be limited due to the flange strength.

★2. Refer to page A-17 for the details of F5-06-A-1021 and F5-06-B-1021.

MT Series Electric Motors

AR/A/A3H series variable displacement piston pumps and PV2R series vane pumps can be installed directly to these electric motors. The power output range is from 0.75 to 18.5 kW.

Two types are available: directly connected type in which the pump shaft is directly inserted in the hollow motor shaft (models M1 and M2); and bell housing type in which couplings are used (models M3 to M7).

- Easy to install a pump
- Free from worry about noise and vibration caused by insufficient centering.
- Compact in size, requiring less space for installation.
- Safe because the rotating part is not exposed.

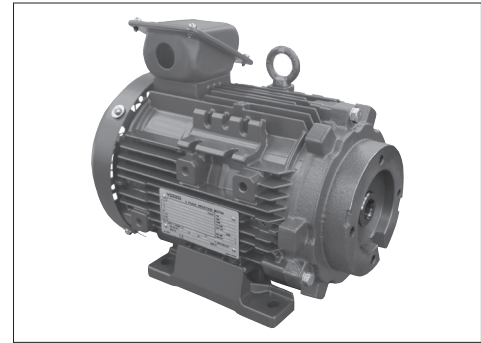

Specifications

Model Numbers	Output × Number of Poles	Voltage-Frequency V Hz	Rated Current A	Starting Current A	Rotational Speed r/min	Insulation Class	Mass kg	Type Ambient Conditions in Using
M1-0.75-41	0.75 kW×4P	200-50 200-60 220-60	3.8 3.4 3.4	27.3 23.8 26.2	1440 1730 1745	F	17.5	<ul style="list-style-type: none"> ●Type Total Enclosed Splash Proof Type (IP44 IC411, IEC60034-1) ●Ambient Conditions in Using Location : Indoor Room Ambient Temperature Range : -20 to +40 °C Ambient Humidity : 100 % RH or less (bedewing must be avoided) Altitude : 1000 m or less To be nothing corrosive and explosive gasses and steam.
M1-1.5-41	1.5 kW×4P	200-50 200-60 220-60	6.8 6.4 6.0	46.6 41.0 45.1	1445 1740 1750	F	22.0	
M1-2.2-41	2.2 kW×4P	200-50 200-60 220-60	10.6 9.4 9.2	96.0 81.0 89.1	1460 1755 1765	F	30.0	
M1-3.7-41 M2-3.7-40	3.7 kW×4P	200-50 200-60 220-60	15.6 14.6 13.8	134 118 130	1460 1755 1765	F	41.0	
M2-5.5-40 M3-5.5-40 M4-5.5-40 M5-5.5-40 M6-5.5-40	5.5 kW×4P	200-50 200-60 220-60	23.4 21.4 20.6	200 166 183	1465 1760 1765	F	62.0 63.0 65.0 68.0	
M2-7.5-40 M3-7.5-40 M4-7.5-40 M5-7.5-40 M6-7.5-40 M7-7.5-40	7.5 kW×4P	200-50 200-60 220-60	30.8 28.6 27.4	264 218 240	1460 1755 1765	F	75.0 74.0 76.0 77.5	
M4-11-40 M5-11-40 M7-11-40	11 kW×4P	200-50 200-60 220-60	46.0 42.0 40.0	365 302 332	1475 1770 1775	F	114.0 131.0	
M4-15-40 M5-15-40 M7-15-40	15 kW×4P	200-50 200-60 220-60	58.8 55.6 52.0	484 408 449	1470 1760 1770	F	131.0	
M4-18.5-40 M5-18.5-40	18.5 kW×4P	200-50 200-60 220-60	74.0 69.0 65.0	668 524 576	1475 1770 1775	F	193.0	

★1. For motors other than those for 200 / 220 V AC, please contact us.

Application

Model Numbers	Piston Pumps			Vane Pumps★1
	Single Pumps	Double Pumps	Variable / Fixed Double Pumps	
M1- * -41 M3- * -40	AR16/AR22/A10/A16/A22	A1616/A1622/A2222	A16R1/A22R1	PV2R1
M2- * -40 M4- * -40	A37 (excluding 04E)	-	-	PV2R2★2
M5- * -40	A37 (04E) /A56	A1637/A2237/A1656/A2256	A37R1/A56R1	-
M6- * -40	A3H16	-	-	-
M7- * -40	A3H37	-	-	-

★1. Vane pump is also possible. However, different mounting bolt is required in order to install the vane pumps.

★2. This pump is special designed product. Please contact us for further details.

Model Number Designation

M1	-1.5	-R	-41
Series Number	Motor Capacity	Terminal Box Location ^{★1}	Design Number
M1 [For AR16/AR22/A10/A16/A22]	0.75: 0.75 kW×4P, 1.5: 1.5 kW×4P, 2.2: 2.2 kW×4P, 3.7: 3.7 kW×4P	[When viewed from the pump mounting surface] None: Upper Side (Standard) R: Right Side L: Left Side	41
M2 [For A37 (excluding 04E)]	3.7: 3.7 kW×4P, 5.5: 5.5 kW×4P, 7.5: 7.5 kW×4P		40
M3 [For AR16/AR22/A10/A16/A22]	5.5: 5.5 kW×4P, 7.5: 7.5 kW×4P		
M4 [For A37 (excluding 04E)]	5.5: 5.5 kW×4P, 7.5: 7.5 kW×4P, 11: 11 kW×4P, 15: 15 kW×4P,		
M5 [For A37(04E)/A56]	18.5: 18.5 kW×4P		
M6 [For A3H16]	5.5: 5.5 kW×4P, 7.5: 7.5 kW×4P		
M7 [For A3H37]	7.5: 7.5 kW×4P, 11: 11 kW×4P, 15: 15 kW×4P		

★1. For the following models, either the left or right side terminal box location is selectable [the upper side (standard) terminal box is not available].
M1-0.75 / M4-18.5 / M5-18.5

ASR Series AC Servo Motor Driven Pumps

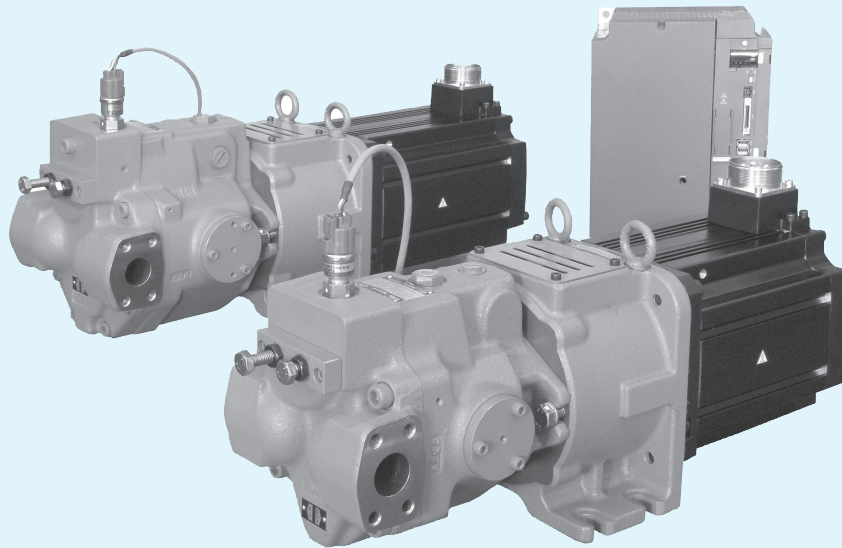

“ASR” Series AC Servo Motor Driven Pumps

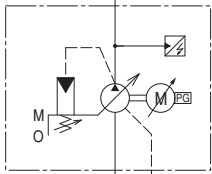
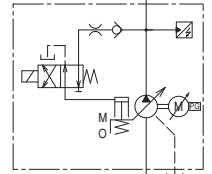
Pump Type	Graphic Symbols	Geometric Displacement cm ³ /rev					Maximum Operating Pressure MPa	Page
		0	2	5	10	20		
ASR Series AC Servo Motor Driven Pumps	 Single Displacement Type	ASR1					21	A-214
		ASR2					16	
	ASR3							
	ASR5					21		
	ASR10							
	 Dual Displacement Type							

■ AMSR Controller A-226

Hydraulic Fluids

Hydraulic Fluids

Use clean petroleum base oils equivalent to ISO VG32 or 46. The recommended viscosity range is from 20 to 400 mm²/s and temperature range is from 0 to 60 °C, both of which have to be satisfied for the use of the above hydraulic oils.

Control of Contamination

Due caution must be paid to maintaining control over contamination of the operating oil which can otherwise lead to breakdowns and shorten the life of the unit. Please maintain the degree of contamination within NAS class 9.

The suction port must be equipped with at least 100 μm (150 mesh) reservoir type filter and the return line must have a line type filter of under 10 μm.

Instructions

Transportation

For transportation, use the lifting rings on the pump. Do not use lifting cables at places other than the lifting rings.

Mounting

When installing the pump, the filling port should be positioned upwards.

Suction Pressure

Permissible suction pressure at the inlet port of the pump is between -16.7 and +50 kPa. For piping to the suction port, use pipes of the nominal diameters shown below. Make sure that the height of the pump suction port is lower than the oil level in the reservoir.

Model	Nominal Dia.
ASR1/ASR2	3/4
ASR3/ASR5	1 1/4
ASR10	2

Hints on Piping

When using steel pipes for the suction or discharge ports, excessive load from the piping to the pump generates excessive noise. Whenever there is fear of excessive load, please use rubber hoses.

Drain Piping

Install drain piping according to the chart and ensure that pressure within the pump housing should be maintained at a nominal pressure of less than 0.1 MPa and surge pressure of less than 0.5 MPa.

The length of piping should be less than 1 m. Instead of joining the drain pipe to other return lines, run it independently. The pipe end should be submerged in oil.

[Recommended Drain Piping Size]

Model	Fitting Size	Inside Dia. of Pipe
ASR1/ASR2	3/8 (Inside Dia. 8.5 mm or more)	10 mm or more
ASR3	1/2 (Inside Dia. 12 mm or more)	12 mm or more
ASR5/ASR10	3/4 (Inside Dia. 16 mm or more)	19 mm or more

Starting

Before first starting, fill the pump case with clean operating oil via the filling port. In order to avoid air blockage when first starting, adjust the control valves so that the discharged oil from the pump is returned directly to the reservoir or the actuator moves in a free load.

Bleeding Air

It may be necessary to bleed air from the pump case and lines to remove causes of vibration. An air bleed valve (Model Number: ST1004-*-10*, Page A-259) in the outlet line is recommended. For air bleeding with an air bleed valve installed, run the pump at a rotational speed that provides a flow rate equal to/higher than the valve's flow rate to reseating.

[Volume of Pre-fill Oil Required]

Model	Volume cm ³
ASR1/ASR2	600
ASR3/ASR5	1200
ASR10	2500

Setting Safety Valve (Pressure) and Delivery

At the time of shipment, the unit has been preset to the delivery rate shown below; the safety valve has been set to 21 MPa (19.5 MPa for ASR2). Adjust the preset delivery and safety valve (pressure) to meet your system requirements.

[Default Setting of Delivery]

Model Numbers	Single Displacement Type "X"cm ³ /rev	Dual Displacement Type "W"cm ³ /rev	
		Large Displacement	Small Displacement
ASR1	15.8	15.8	8
ASR2	22.2	22.2	8
ASR3	36.9	36.9	10
ASR5	56.2	56.2	14
ASR10	100	100	20

Adjustment of Delivery

Turning the flow adjustment screw for the single displacement type or the large displacement side flow adjustment screw for the dual displacement type clockwise decreases delivery. Turning the small displacement side flow adjustment screw for the dual displacement type clockwise increases delivery.

[Volume adjusted by each full turn of the flow adjustment screw]

Model Numbers	Single Displacement Type "X"cm ³ /rev	Dual Displacement Type "W"cm ³ /rev	
		Large Displacement	Small Displacement
ASR1	1.4	1.4	1.5
ASR2	2.0	2.0	2.1
ASR3	2.9	2.9	2.8
ASR5	3.9	3.9	3.7
ASR10	5.4	5.4	7.9

★ For the relationship between the flow adjustment screw position and flow adjustment, see pages A-217 and A-218.

Adjustment of Safety Valve (Pressure)

Single Displacement Type

Turning the pressure adjustment screw clockwise increases pressure.

See the chart for the pressure change per turn of the adjustment screw. After adjustment, be sure to tighten the lock nut.

Model Numbers	Pressure Change Per Turn MPa	Max. Setting Value MPa	Min. Setting Value MPa
ASR1/ASR3/ASR5-**-HX	4.4	24.8	8
ASR10-**-HX			2
ASR2-*C-CX		19.5	2

★ For the relationship between the pressure adjustment screw position and pressure adjustment, see page A-217.

Dual Displacement Type

The dual displacement type does not support the full cut-off function. Provide a safety valve on the pump discharge side. Set the safety valve at a value of the maximum operating pressure + 3 to 3.5 MPa.

Precautions During Operation

During and for a period after operation, the surface temperature of the AC servo motor and the pump will be hot. Prevent hands and other body parts from coming into contact with them.

Providing flexible flow/pressure control !

ASR Series AC Servo Motor Driven Pumps

The ASR series provides variable flow by driving a piston pump directly with an AC servo motor and controlling the rotational speed in a range from zero to the maximum level. This series allows precise control of flow/pressure by using a dedicated AMSR controller. It also offers excellent response and repeatability.

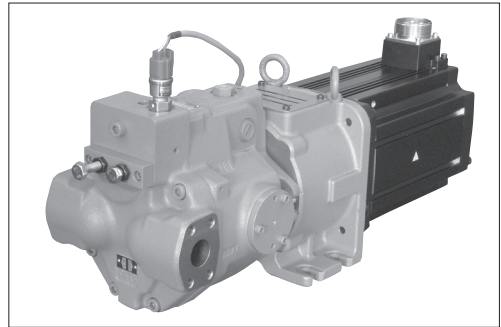

System Configuration

A feedback loop is formed by the AMSR controller that computes deviations between control signals from the machine side (speed and pressure commands) and sensor signals to drive the AC servo motor accordingly. Control parameters can be set digitally by using dedicated software.

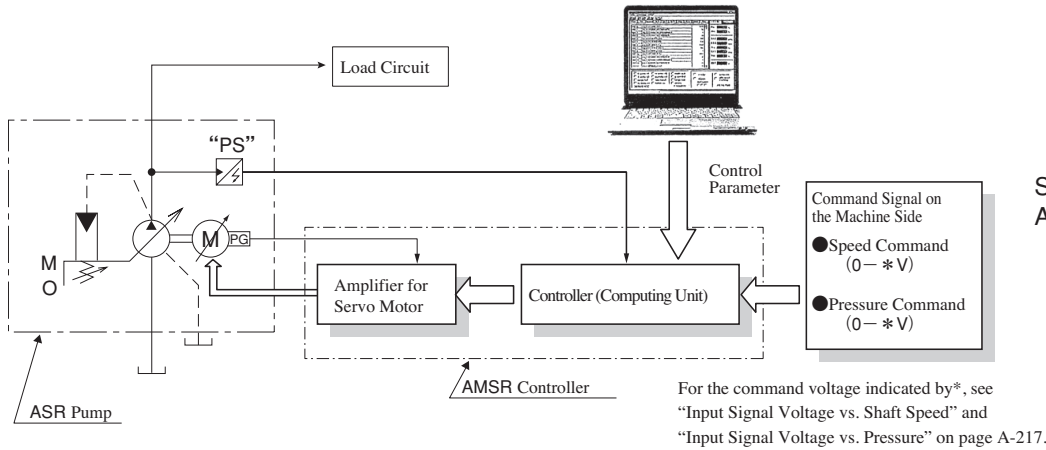

Graphic Symbols

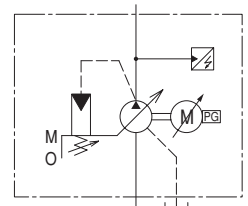

Single Displacement Type
ASR * - * * - * X * -

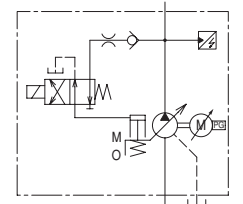

Dual Displacement Type
ASR * - * * - * W * -

Energy saving with low heat generation

These pumps run at a rotational speed suitable for mechanical requirements, eliminating unnecessary power loss. They minimize heat generation in the fluid and allow the use of a significantly smaller reservoir.

Example of Power Consumption by Pump Control Type

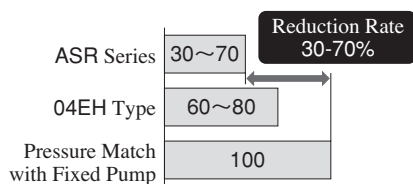

Low noise

The motor operates at near-zero speed during unloaded operation or pressure control, keeping the noise level extremely low.

High performance

The AC servo motor, which directly controls the pump speed, improves response and stability at low pressures and speeds.

Digital AMSR controller that saves space and wiring

The integration of the amplifier for the servo motor and the controller saves space and wiring. The parameters can be digitally adjusted in an easy and repeatable way.

Dual displacement type for a wider operation range

The dual displacement type has a solenoid operated directional valve to switch between large and small swash plate angles. A single pump unit of the dual displacement type can operate both with low pressure/large flow and with high pressure/small flow. Thus, in comparison to the single displacement type with the same motor capacity, the dual displacement type covers a significantly wider range of operating pressures and flow rates.

Large flow

The AMSR controller has a combination function that supports operation with large flow up to 3200 L/min (ASR10 x 16 units).

Specifications

Descriptions		Model Numbers									
		ASR1-	ASR2-	ASR3-		ASR5-	ASR10-				
Power Capacity		C	C	E	G	J	M				
Pump	Flow Control	Max. Flow	39.5 L/min	55.5 L/min	92.3 L/min		129 L/min	200 L/min			
		Min. Adj. Flow	1%								
		Hysteresis	1% or less								
		Repeatability	1% or less								
		Input Signal Voltage	31.6 L/min / 5V	44.4 L/min / 5V	73.8 L/min / 5V	112.4 L/min / 5V		200 L/min / 5V			
		Max. Permissible Input Signal Voltage*	39.5 L/min / 6.25V	55.5 L/min / 6.25V	92.3 L/min / 6.25V	129 L/min / 5.75V					
	Pres. Control	Max. Operating Pres.	21 MPa	16 MPa	21 MPa						
		Min. Adj. Pres.	0.1 MPa								
		Hysteresis	1% or less								
		Repeatability	1% or less								
		Input Signal Voltage	17.5 MPa / 5V	16 MPa / 4.57V	17.5 MPa / 5V						
		Max. Permissible Input Signal Voltage*	21 MPa / 6V		21 MPa / 6V						
AC Servo Motor Specifications	Rated Output	4.5 kW			6 kW	8 kW	11 kW	15 kW			
	Insulation Class	Class F									
	Cooling System	Totally-enclosed Self-cooling					Totally-enclosed Fan-cooling				
		Cooling Fan Power Consumption	—————					62W (50Hz)/76W (60Hz)			
	Environmental Condition	Ambient Temperature	0 - +40 °C (No Freezing)								
Ambient Humidity		80 %RH or less (No Condensation)									
Mass	Single Displacement Type	54 kg	54 kg	80 kg	87 kg	94 kg	175.5 kg	213 kg	233 kg		
	Dual Displacement Type	55 kg	55 kg	82 kg	89 kg	96 kg	177.5 kg	214 kg	234 kg		
Applicable Controller Model Number		AMSR- *C- *00-10			AMSR- 2DE- *00-10	AMSR- *FGI- *00-10		AMSR- *HJL- *00-10	AMSR- *KMO- *00-10		

*By adjusting the controller, the maximum flow rate/5 V (39.5 L/min/5 V) and the maximum operating pressure/5 V (21 MPa/5 V) can be set.

Model Number Designation

The model numbers below indicate packages each containing an AC servo motor driven pump, AMSR controller, and Regeneration Resistors.

ASR3	-4	G	-H	X	S	A100	N	-A	00	-12
Series Number	Power Supply Voltage	Power Capacity	Max. Operating Pres.	Flow Setting	Port Direction	Coil Type for Solenoid Operated Directional Valve	Electrical Conduit Connection for Solenoid Operated Directional Valve	Function Selection	Parameter Number	Design Number
ASR1	None : 200 V AC 4 : 400 V AC	C	H : 21 MPa	X : Single Displacement Type W : Dual Displacement Type	S : Side None : Axial	AC A100 :100 V AC A120 :120 V AC A200 :200 V AC A240 :240 V AC	None: Terminal Box N:DIN Plug-in Connector (Optional)	A: Single B: Combination (Single Operation Allowed)	00: Standard	12
ASR2		C	C : 16 MPa			D12 :12 V DC D48 :48 V DC D110 :110 V DC D200 :200 V DC D220 :220 V DC				12
ASR3		E*, G				R100 :100 V AC R110 :110 V AC R200 :200 V AC R220 :220 V AC				12
ASR5		G, J	H : 21 MPa							12
ASR10		J, M				A:Horizontal B:Vertical				12

*1. To order an AC servo motor driven pump separately for spare use, prefix "N-" to the model number and omit the Function Selection and Parameter Number.

Example) N-ASR3-4G-HXSA100N-12

*2. For the relationship between the power capacity and the pressure/flow in terms of specification limits, see charts on pages A-219 and A-220.

*3. When selecting the power capacity "E", only an input voltage of 200 V AC is available.

*4. Types shown in the shaded areas are optional. Check the delivery date before selecting them.

*5. This is applicable only when "W" is selected for flow setting.

*6. The following symbol is added the column of electrical wiring system of solenoid valves. (except for ASR2)

M : Terminal Box Type (without manual actuator)

P : Plug-in Connector Type (without manual actuator)

*7. For combination operation, consult us separately regarding the types of hydraulic circuits, components, and electric cables.

■ Solenoid Ratings

Please see the solenoid ratings on page A-51.

■ Pipe Flange Kit

No pipe flange kit is included with the pump. The pipe flange kits below are available if required. For the details of the pipe flange kits, see pages A-258 and A-259.

Pump Model Numbers	Name of Port	Pipe Flange Kit Numbers		
		Threaded Connection	Socket Welding [★]	Butt Welding
ASR1 ASR2	Suction	F5-06-A-10	F5-06-B-10	F5-06-C-10
	Discharge	F5-06-A-10	F5-06-B-10	F5-06-C-10
ASR3 ASR5	Suction	F5-10-A-10	F5-10-B-10	F5-10-C-10
	Discharge	F5-10-A-10	F5-10-B-10	F5-10-C-10
ASR10	Suction	F5-16-A-10	F5-16-B-10	F5-16-C-10
	Discharge	F5-10-A-10	F5-10-B-10	F5-10-C-10

★ For the socket welding type F5-06-B-10 or F5-10-B-10, the operating pressure may be limited due to the flange strength.

Characteristics of Single Displacement Type

Input Signal Voltage vs. Pressure

● ASR1/ASR3/ASR5/ASR10- ** -HX

● ASR2- * C-CX

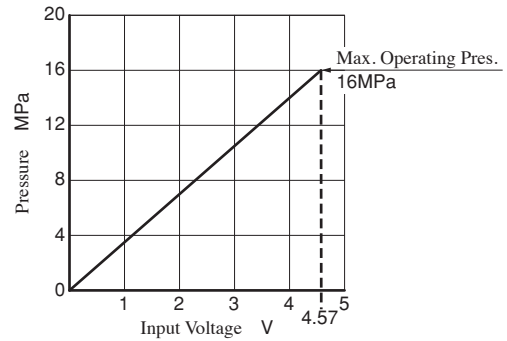
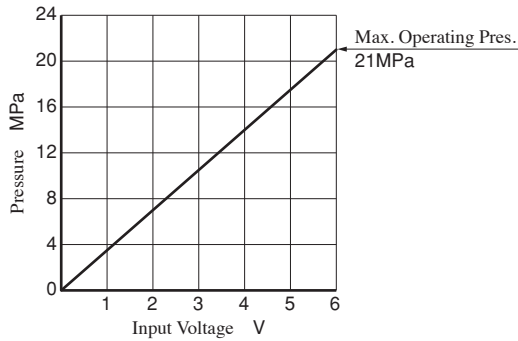

★ Do not input a voltage higher than the level corresponding to the maximum operating pressure.

Input Signal Voltage vs. Shaft Speed

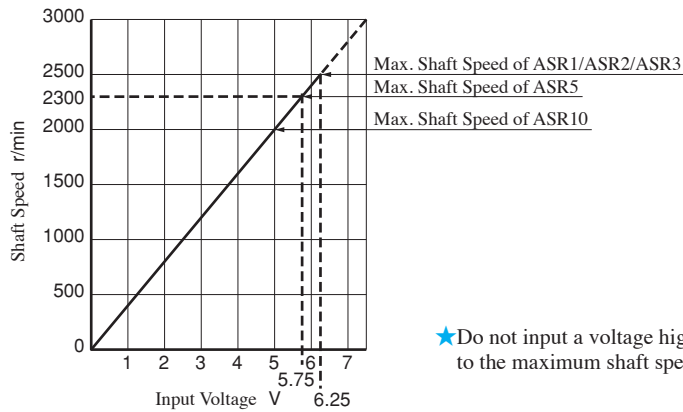

★ Do not input a voltage higher than the level corresponding to the maximum shaft speed.

Safety Valve Pressure Adjustment Screw Projection and Safety Valve Setting Pressure

● ASR1/ASR3/ASR5- ** -HX

● ASR2- * C-CX

● ASR10- ** -HX

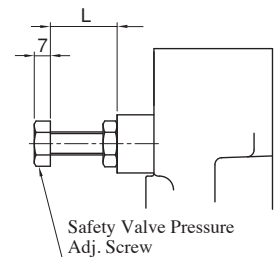
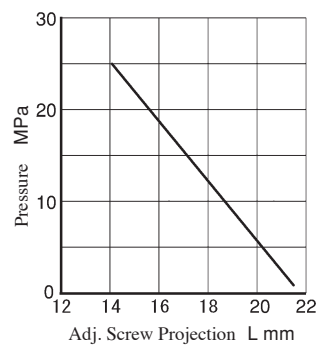
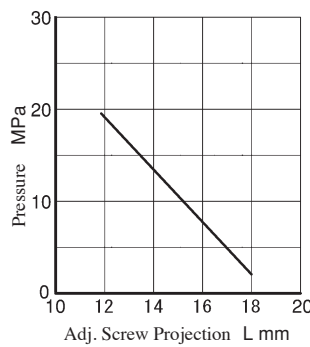
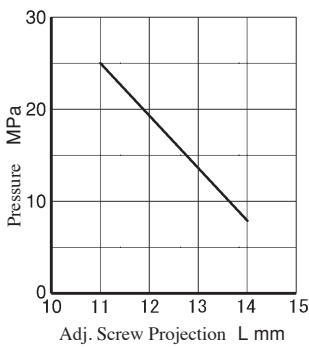

Flow Adjustment Screw Projection and Geometric Displacement

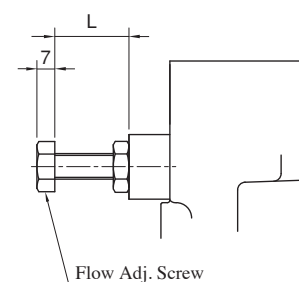
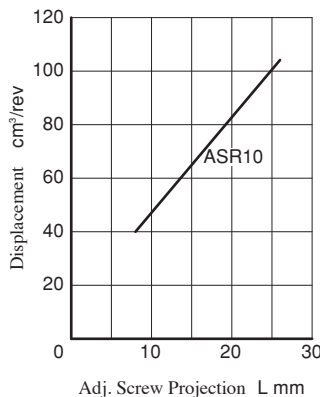
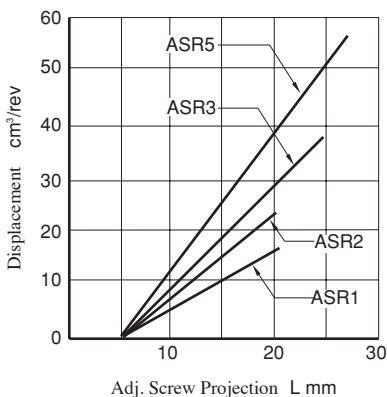

Characteristics of Dual Displacement Type

■ Input Signal Voltage vs. Pressure

See “Characteristics of Single Displacement Type” (page A-217).

■ Input Signal Voltage vs. Shaft Speed

See “Characteristics of Single Displacement Type” (page A-217).

■ Flow Adjustment Screw Projection and Geometric Displacement

Large Displacement Side Flow Adj. Screw (Check operation with the solenoid operated directional valve “off”.)

This is the same as the single displacement type. See “Characteristics of Single Displacement Type” (page A-217).

Note that the value cannot be set below the level set by the small displacement side adjustment screw.

Small Displacement Side Flow Adj. Screw (Check operation with the solenoid operated directional valve “on” and at a load pressure of 3 MPa or more.)

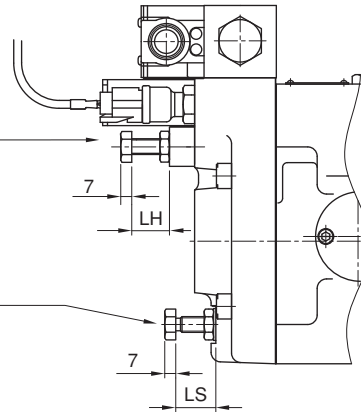

[Small Displacement]

● ASR1- *C-HW

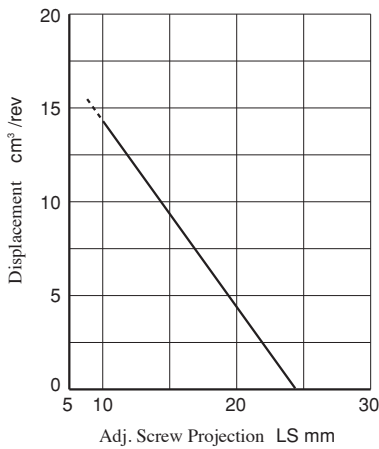

● ASR2- *C-HW

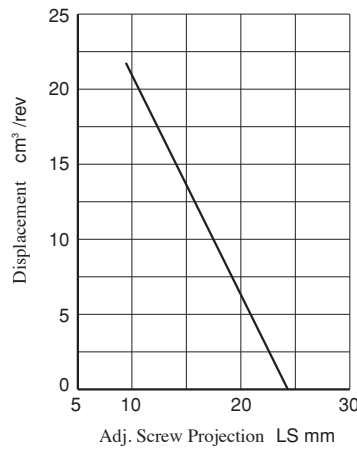

● ASR3- * *-HW

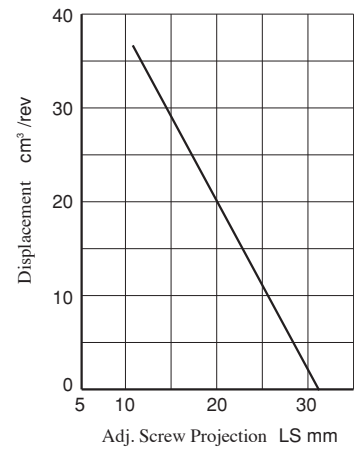

● ASR5- * *-HW

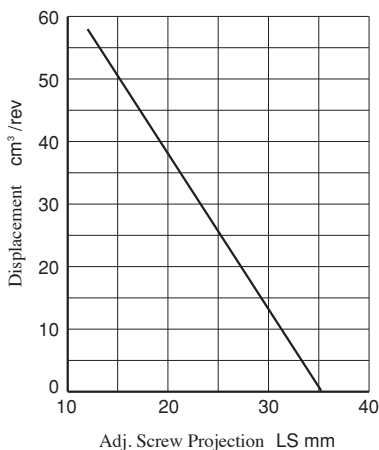

● ASR10- * *-HW

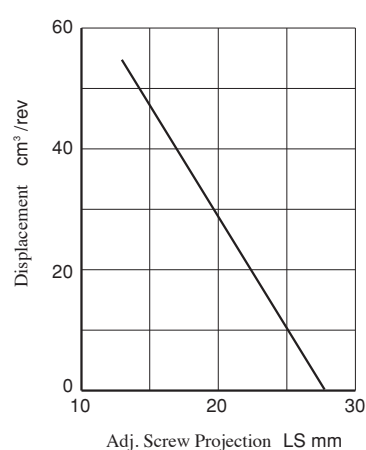

■ Pressure vs. Discharge Flow (Single Displacement Type "W")(Reference)

- · - · - · - · - Max Continuous Operation Time: 100 sec.
- Max Continuous Operation Time: 30 sec.

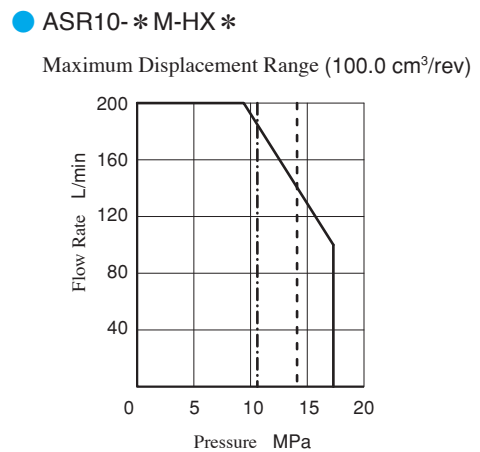
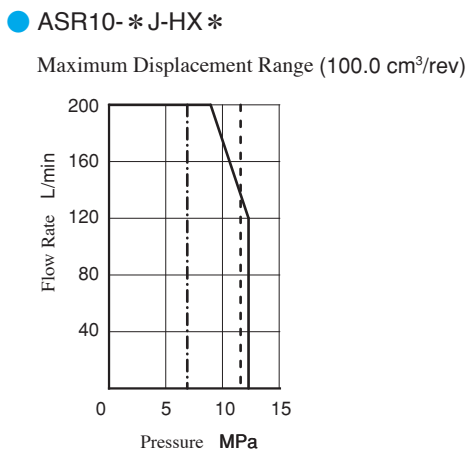
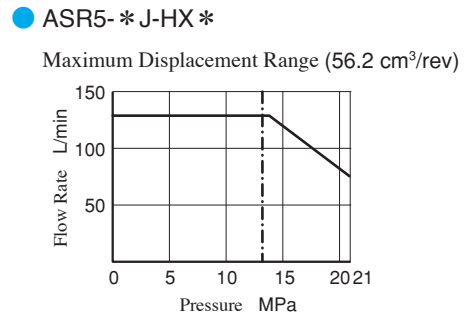
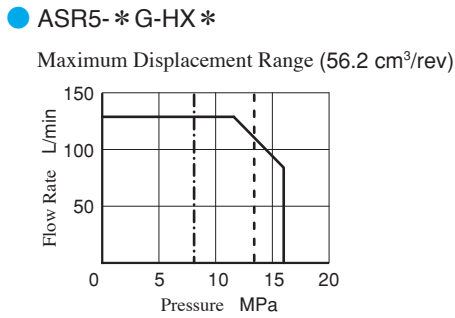
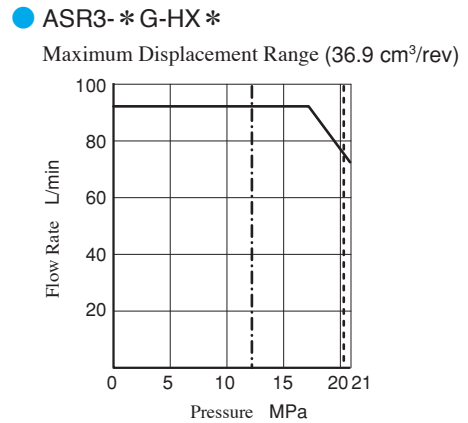
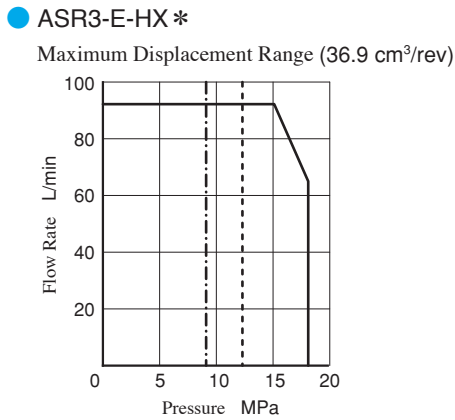
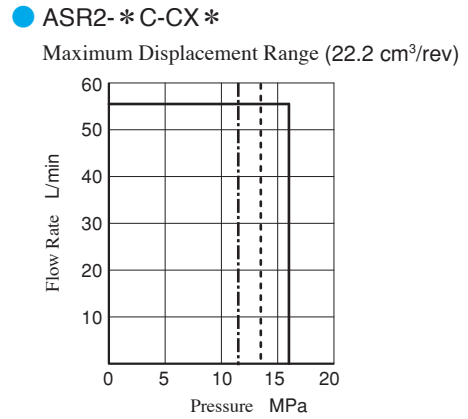
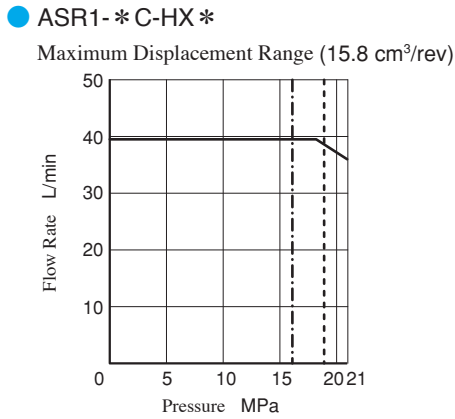

Pressure vs. Discharge Flow (Single Displacement Type "W")(Reference)

- Large Displacement : Max. Continuous Operation Time : 100 sec.
- Large Displacement : Max. Continuous Operation Time : 30 sec.
- //// Small Displacement : Max. Continuous Operation Time

● ASR1- *C-HW *

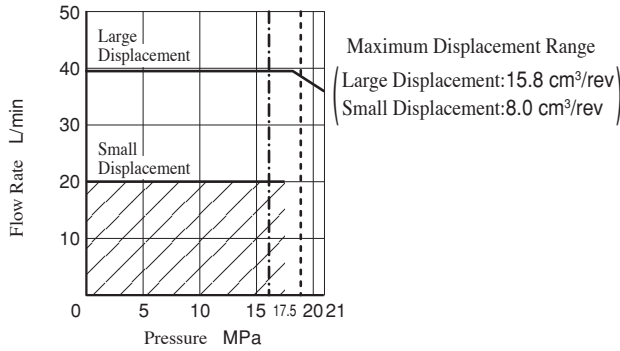

● ASR2- *C-CW *

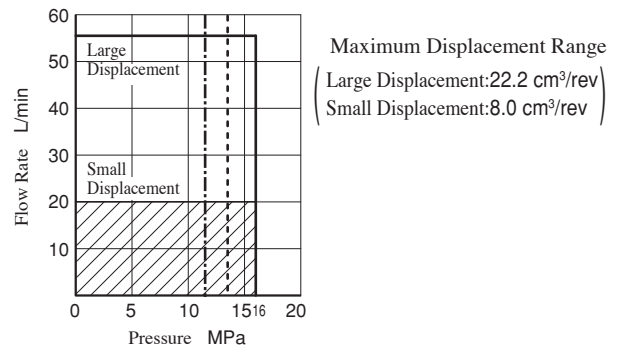

● ASR3-E-HW *

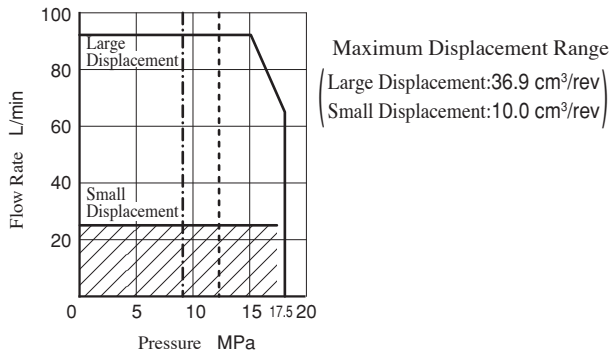

● ASR3- *G-HW *

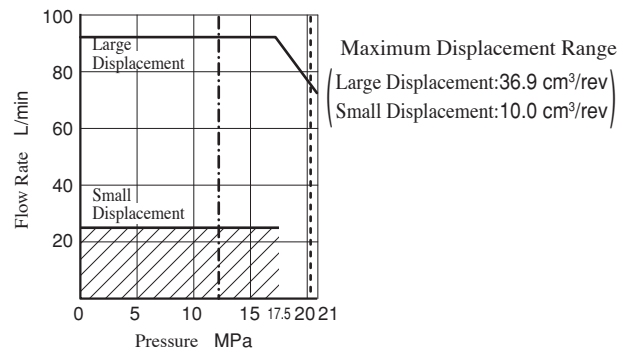

● ASR5- *G-HW *

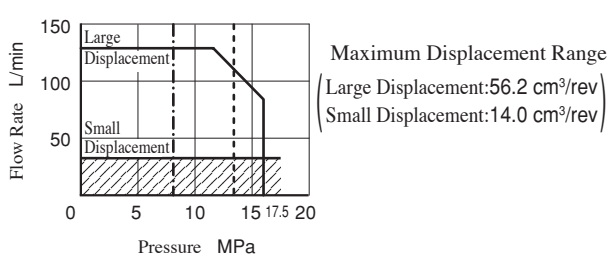

● ASR5- *J-HW *

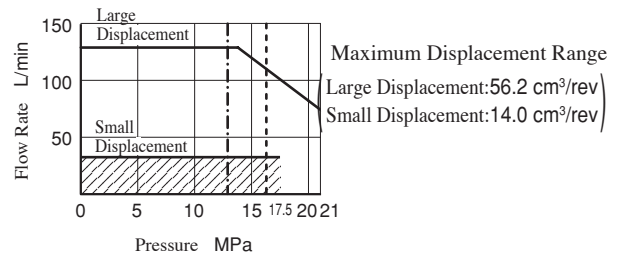

● ASR10- *J-HW *

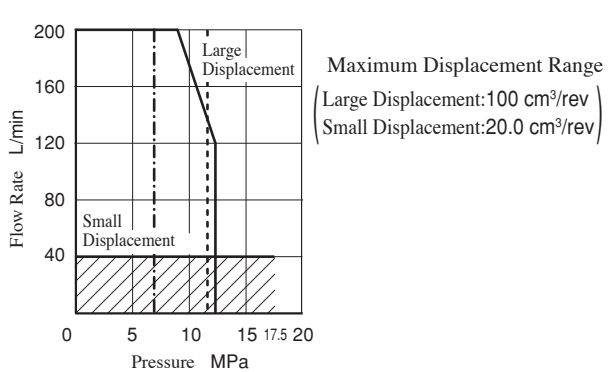

● ASR10- *M-HW *

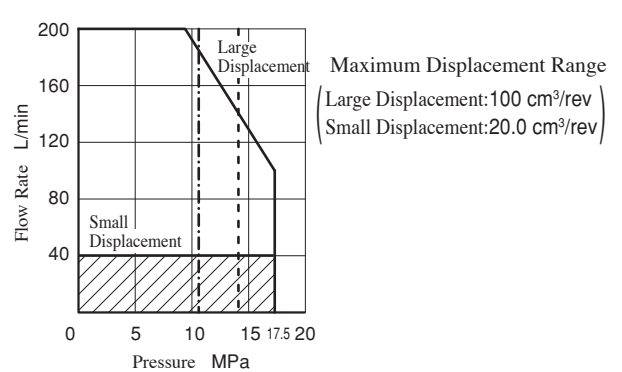

ASR1- * C-HXS- (Side Port Type) ASR2- * C-CXS-

Single Displacement Type

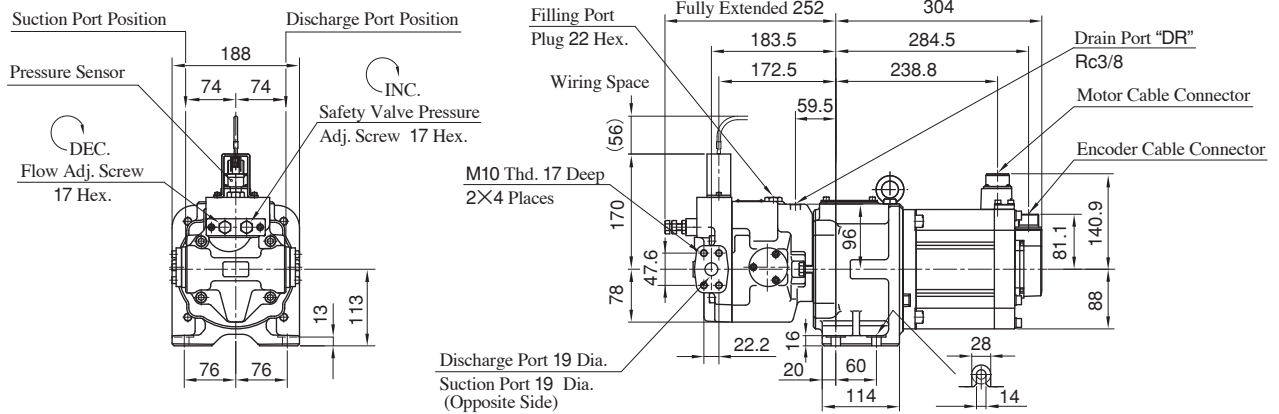

ASR1- * C-HX- (Axial Port Type) ASR2- * C-CX-

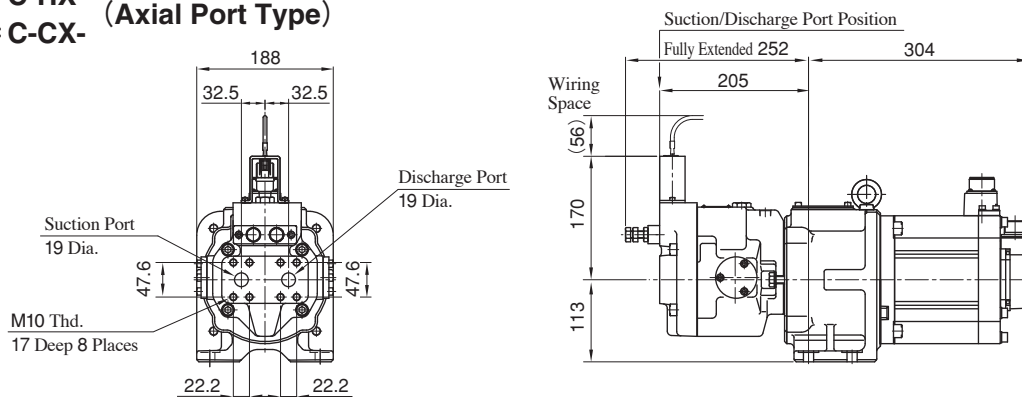

● For other dimensions, see the figure for the side port type.

ASR1- * C-HWS- (Side Port Type) ASR2- * C-CWS-

Dual Displacement Type

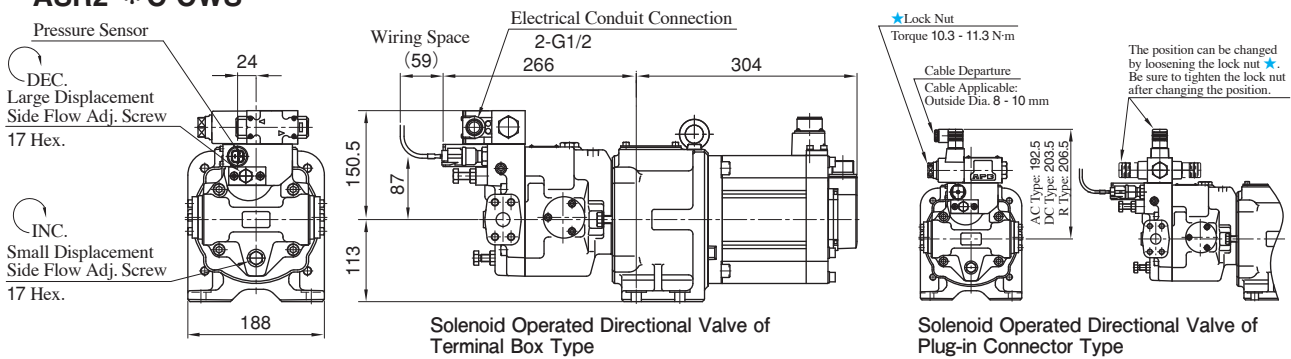

● For other dimensions, see the figure for the single displacement type.

ASR1- * C-HW- (Axial Port Type) ASR2- * C-CW-

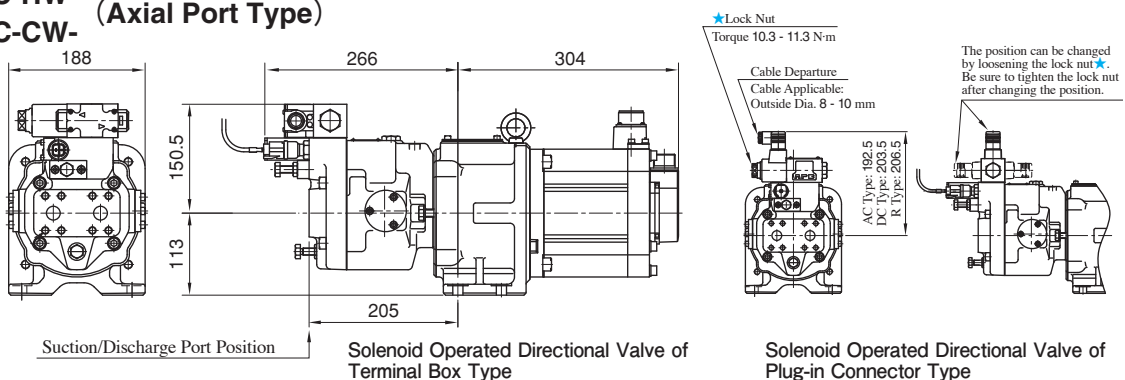

● For other dimensions, see the figure for the single displacement type.

ASR3--HXS- (Side Port Type)**

Single Displacement Type

Model Numbers	A	B	C	D
ASR3-E-H*S-	364	344.5	290.8	149.1
ASR3-*G-H*S-	404	384.5	330.8	149.1

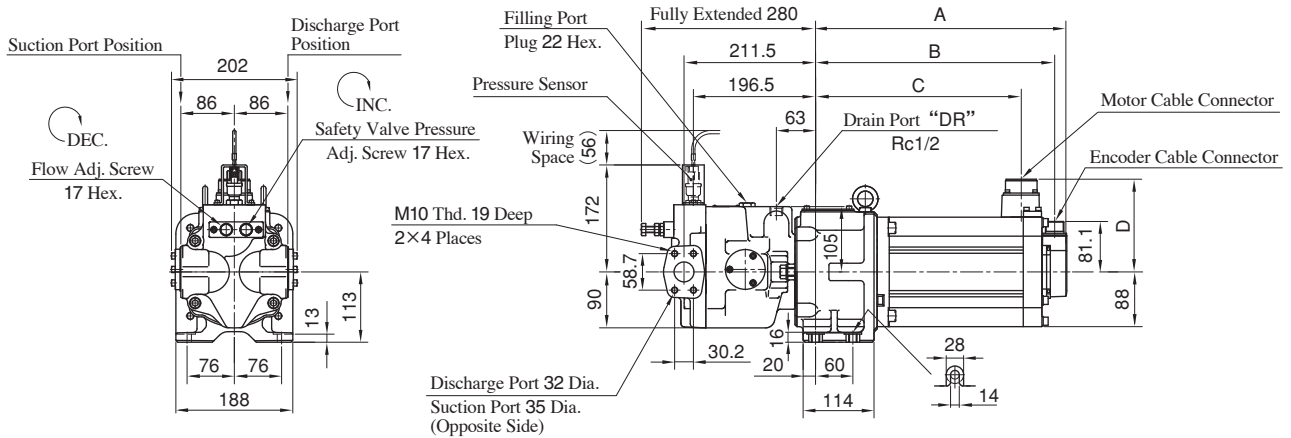

ASR3--HX- (Axial Port Type)**

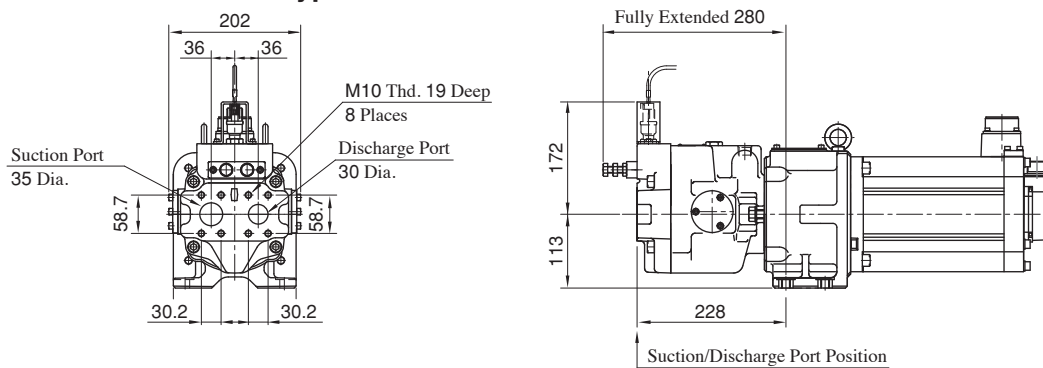

● For other dimensions, see the figure for the side port type.

ASR3--HWS- (Side Port Type)**

Dual Displacement Type

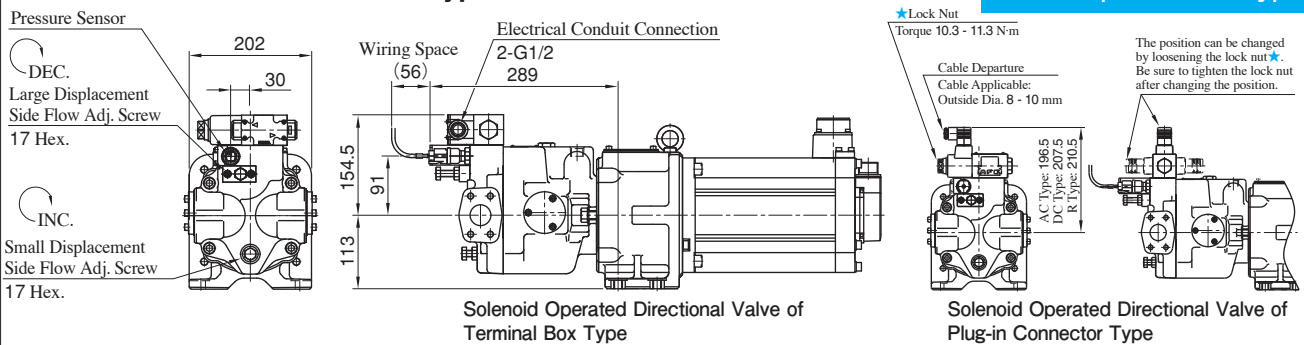

● For other dimensions, see the figure for the single displacement type.

ASR3--HW- (Axial Port Type)**

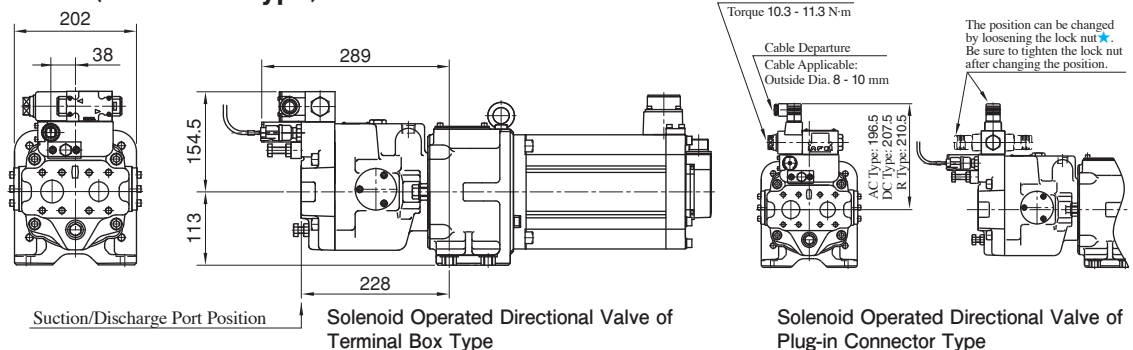

● For other dimensions, see the figures for the single displacement type and the dual displacement side port type.

ASR5- *G-HXS- (Side Port Type)

Single Displacement Type

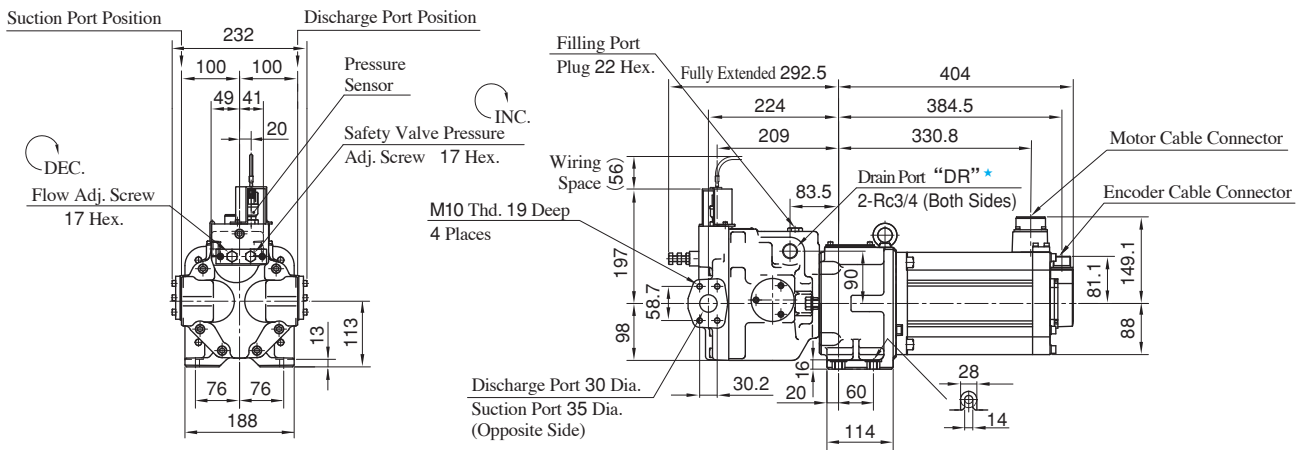

★Use either of two drain ports at your option. Keep the unused port plugged.

ASR5- *G-HX- (Axial Port Type)

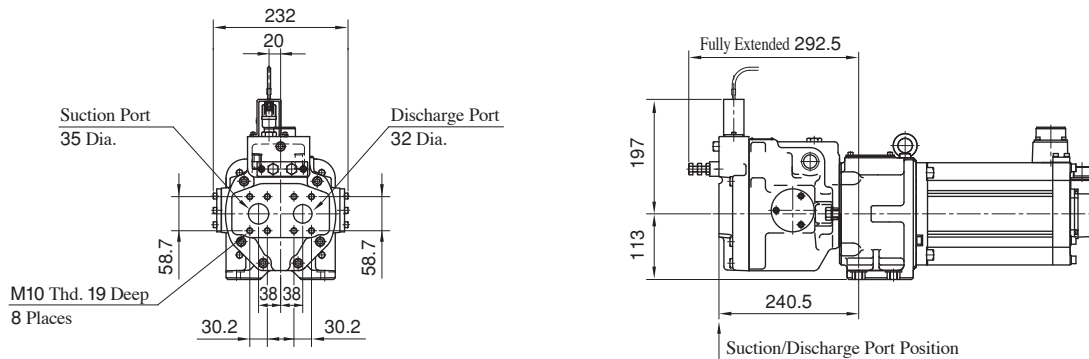

ASR5- *G-HWS- (Side Port Type)

Dual Displacement Type

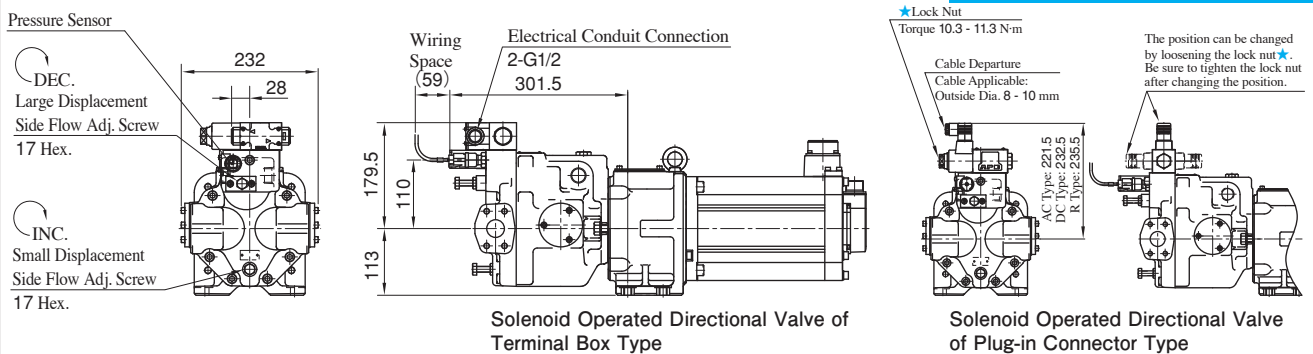

● For other dimensions, see the figure for the single displacement type.

ASR5- *G-HW- (Axial Port Type)

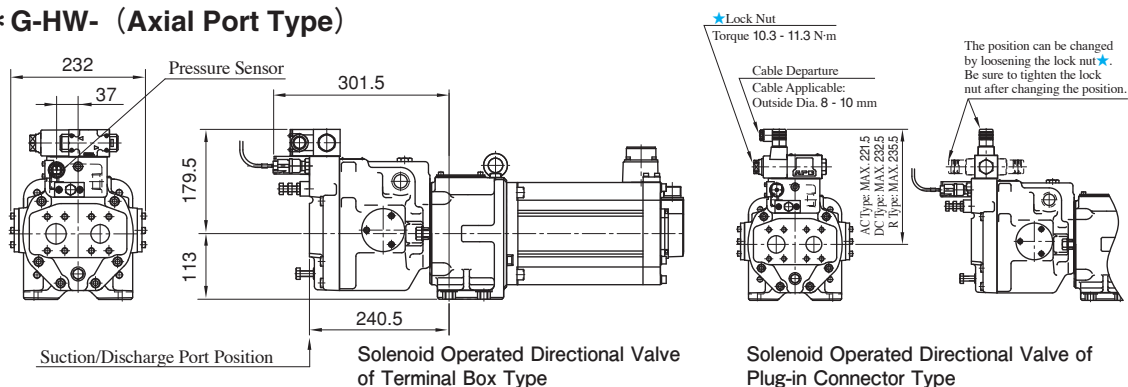

● For other dimensions, see the figures for the single displacement type and the dual displacement side port type.

ASR5- * J-HXS- (Side Port Type)

Single Displacement Type

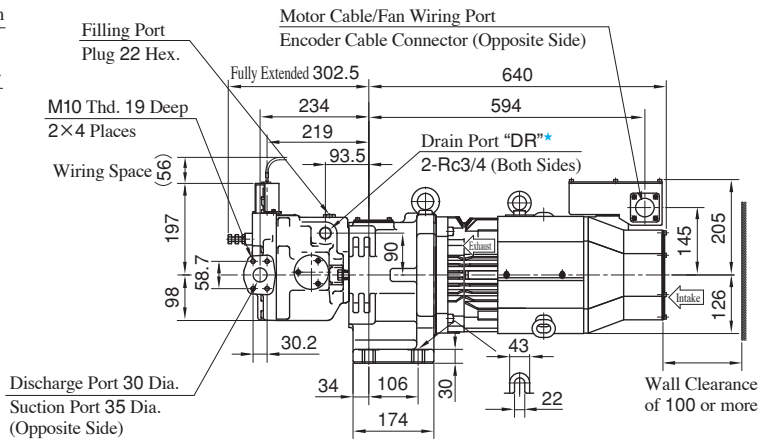
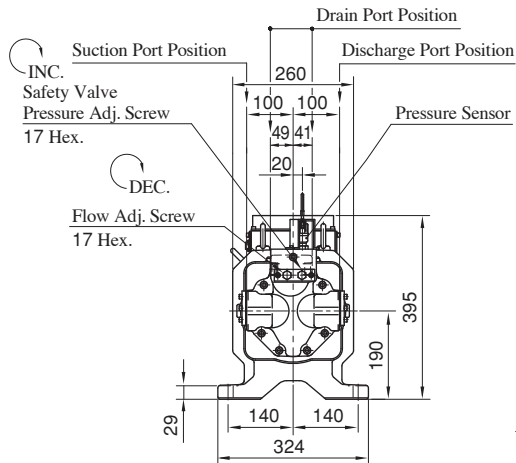

★ Use either of two drain ports at your option. Keep the unused port plugged.

ASR5- * J-HX- (Axial Port Type)

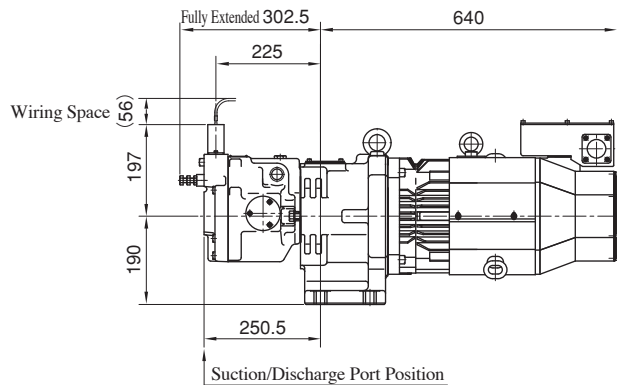
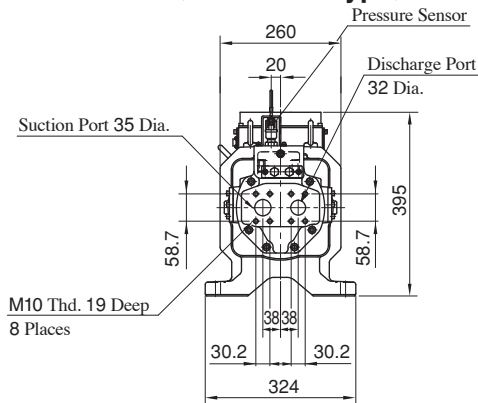

● For other dimensions, see the figure for the side port type.

ASR5- * J-HWS- (Side Port Type)

Dual Displacement Type

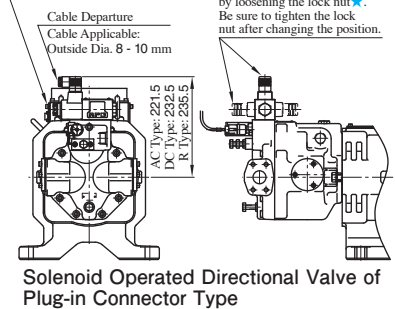
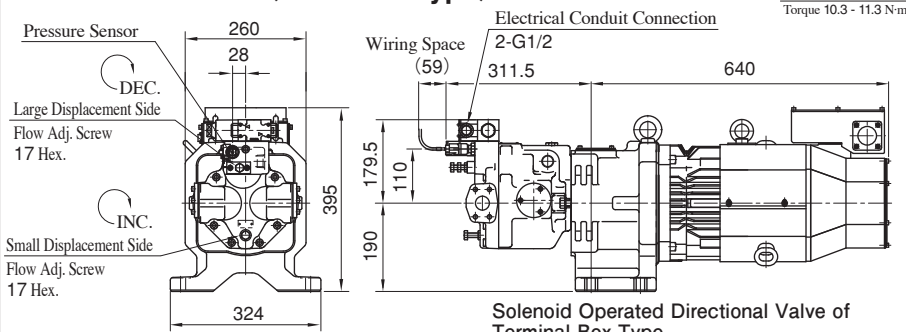

● For other dimensions, see the figure for the single displacement type.

ASR5- * J-HW- (Axial Port Type)

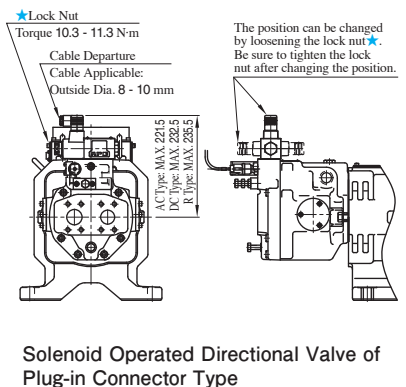
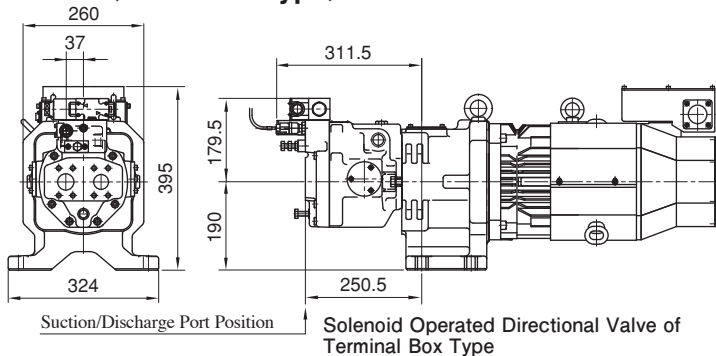

● For other dimensions, see the figures for the single displacement type and the dual displacement side port type.

ASR10-**-HXA- (Horizontal Type)

Single Displacement Type

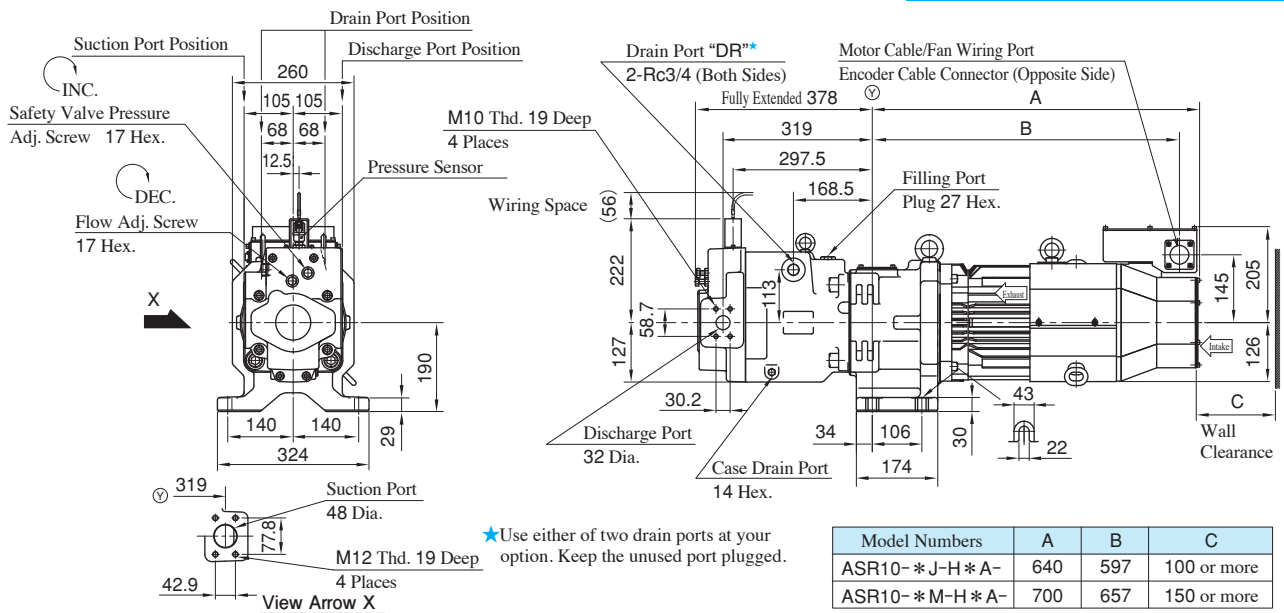

ASR10-**-HXB- (Vertical Type)

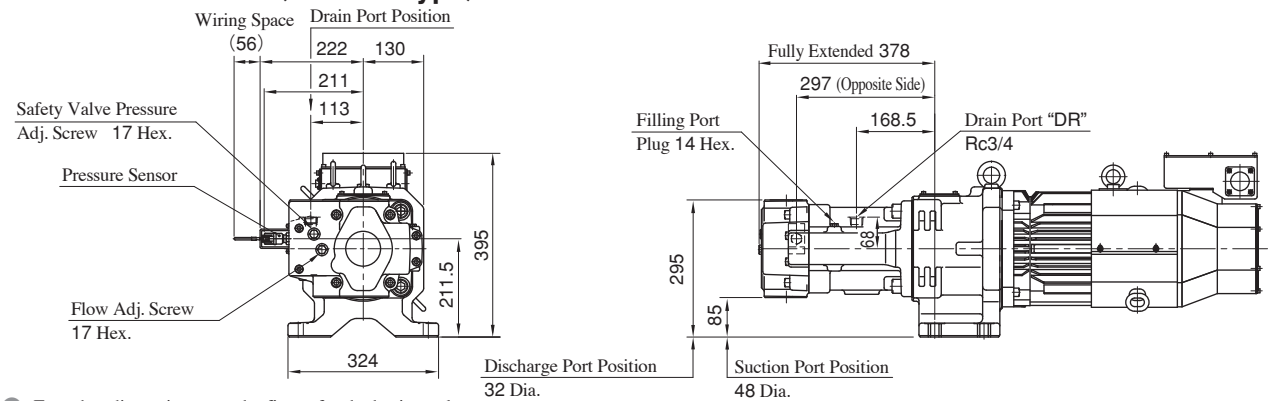

ASR10-**-HWA- (Horizontal Type)

For other dimensions, see the figure for the single displacement type.

Dual Displacement Type

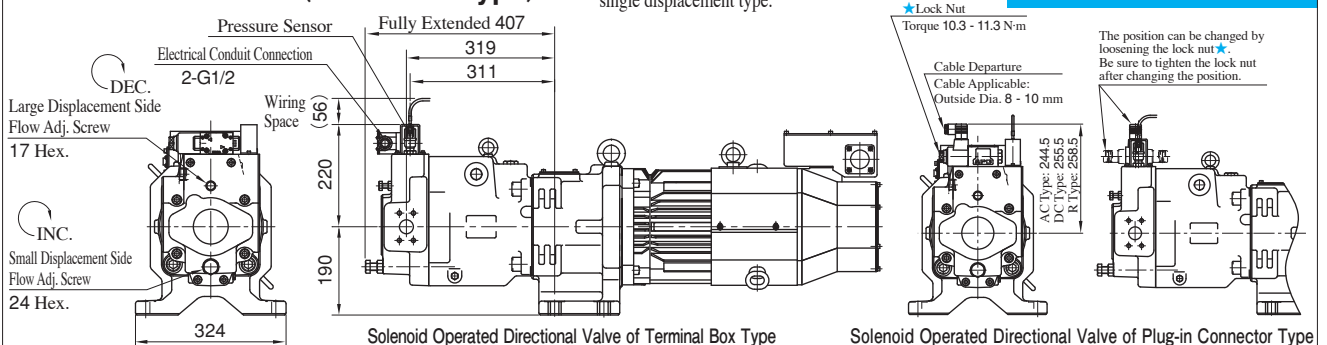

ASR10-**-HWB- (Vertical Type)

For other dimensions, see the figures for the single displacement type and the dual displacement horizontal type.

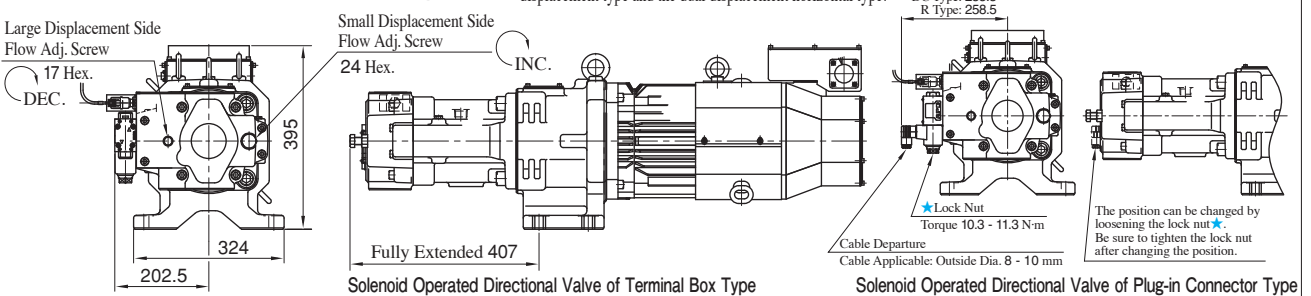

AMSR Controller

The AMSR controller is used to drive ASR series AC servo motor driven pumps. With an optimal design for the ASR pumps, the controller can maximize the pump performance. The AMSR controller is included with the ASR series pumps.



Specifications

Model Numbers		AMSR- *C- *00-10	AMSR-2DE- *00-10	AMSR- *FGI- *00-10	AMSR- *HJL- *00-10	AMSR- *KMO- *00-10
Control Unit Specifications	Command Signal Input Voltage	0 - +10 V DC				
	Command Signal Input Impedance	10 kΩ				
	Monitor Output Voltage	0 - +10 V DC				
	Sequence Input Signal	Photocoupler Input 8ch				
	Sequence Output Signal	Open Collector Output 6ch				
Main Circuit Power	Voltage/Frequency	200 V	200 to 230 V AC, 50/60 Hz, 3-Phase			
		400 V	380 to 480 V AC, 50/60 Hz, 3-Phase			
	Permissible Voltage Fluctuation	200 V	170 to 253 V AC, 3-Phase			
		400 V	323 to 528 V AC, 3-Phase			
Permissible Frequency Fluctuation	Within ±5%					
Power Supply Capacity	6.8 kVA	8.6 kVA	12 kVA	16 kVA	22 kVA	
Regeneration Resistor (Dynamic Brake)	Built-in			External Option		
Cooling System	Fan-cooling, Open (IP 00)					
Environmental Condition	Ambient Temperature	0 - +50 °C (No Freezing)				
	Ambient Humidity	90 %RH or less (No Condensation)				
Protective Functions	<ul style="list-style-type: none"> Overcurrent Shutdown Servo Motor Overheat Protection Undervoltage Protection Excess Error Protection 		<ul style="list-style-type: none"> Regenerative Overvoltage Shutdown Encoder Malfunction Protection Instantaneous Power Failure Protection 		<ul style="list-style-type: none"> Overload Shutdown Regeneration Malfunction Protection Overspeed Protection 	
Mass kg	4.6	6.2	18		19	
Applicable Pump	ASR1- *C ASR2- *C	ASR3-E	ASR3- *G ASR5- *G	ASR5- *J ASR10- *J	ASR10- *M	

Model Number Designation

AMSR	-2	C	-A	00	-10
Series Numbers	Power Supply Voltage	Amplifier Capacity kW	Function Selection	Parameter Number	Design Number
AMSR : AMSR Controller	2 : 200 V AC	DE : 7.0	A : Single B : Combination (Single Operation Allowed)	00 : Standard	10
	2 : 200 V AC	C : 5.0 FGI : 11.0 HJL : 15.0 KMO : 22.0			
	4 : 400 V AC				

AMSR- * C- * 00-10

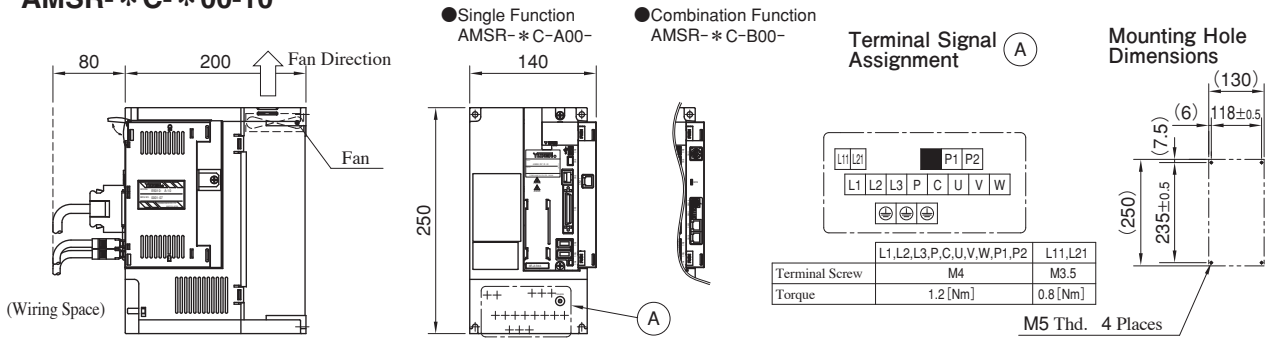

AMSR-2DE- * 00-10

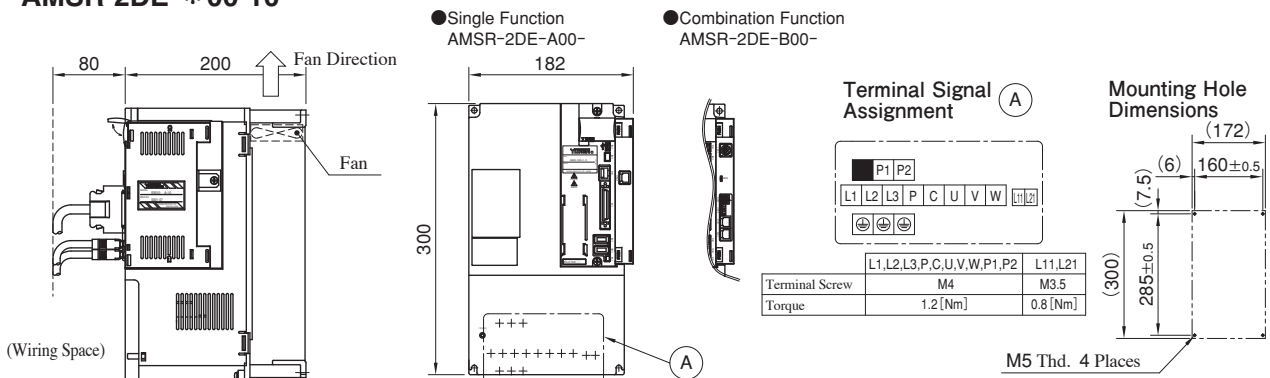

AMSR- * FGI/ * HJL/ * KMO- * 00-10

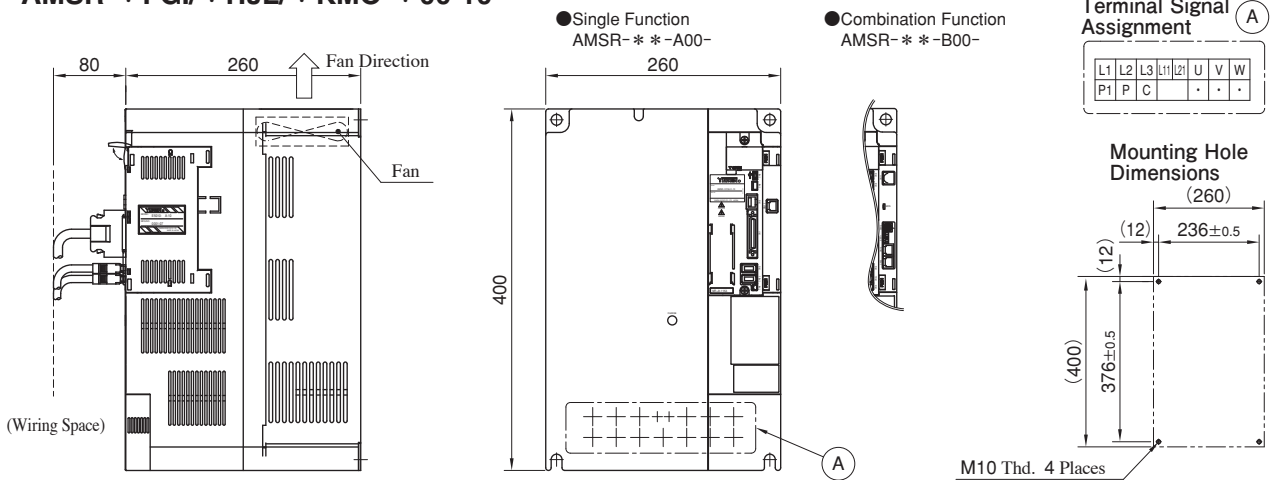

Terminal Symbol	L1-L3, U, V, W, P1, P, C	L11, L12
Terminal Screw Size/ Torque	AMSR- * FGI/ * HJL- * 00-10 AMSR- * KMO- * 00-10	M4/1.2

Installation Standard

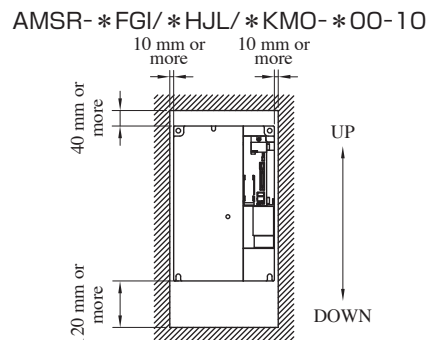
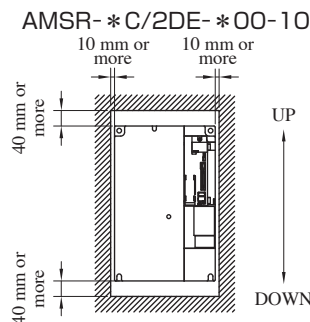

★ Consult us when installing multiple controllers next to each other.

Terminal Names/Appearance

**AMSR- * C-A00-
Single Function**

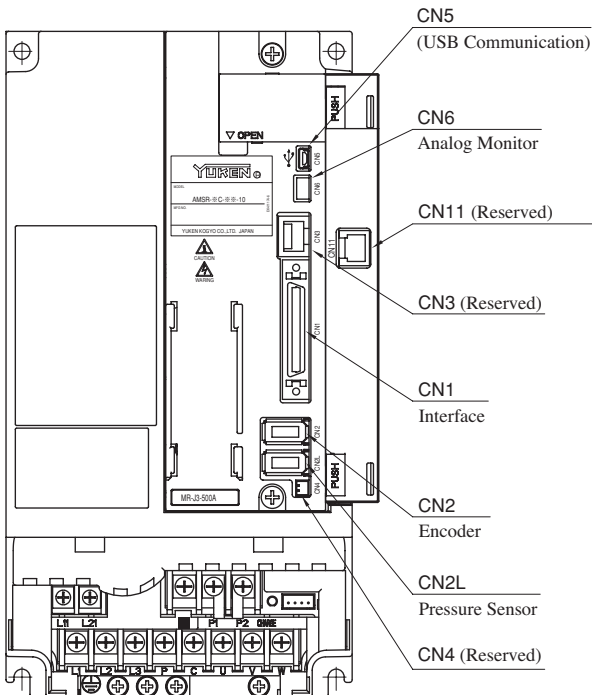

**AMSR- * C-B00-
Combination Function**

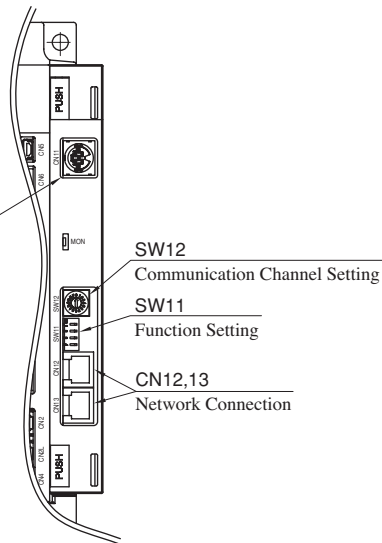

AMSR-2DE-

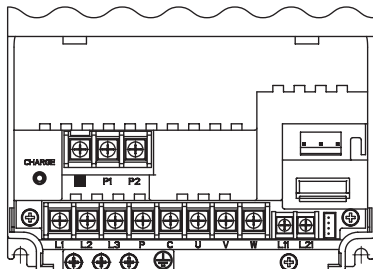

AMSR- * FGI/ * HJL/ * KMO-

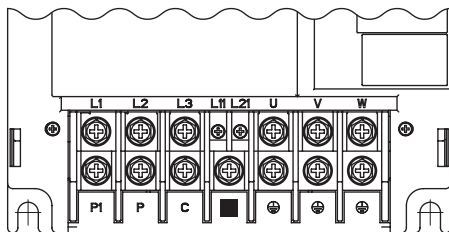

Function	Symbol	Terminal Name	Terminal Channel	Description
Single/ Combination	CN5	USB Communication	—	With the USB communication function, servo operation, parameter change, and monitor function can be performed on a PC. Recommended Cable USB Cable: Mini B Type
			1	For the manufacturer's setting. : Always OFF.
Combination	SW11	Function Selection	2	Reserved.
			3	For switching single and combination operations. OFF: Combination, ON: Single
			4	For network termination setting. OFF: None, ON: 150 Ω
	SW12	Communication Channel Selection	0	Master station
			1~F	Slave station
	CN12, CN13	Network Connection	—	For connection to the network based on the AMSR controller. Recommended Cable TFL-FST- * S (SANWA) MJ-FS * (ELECOM)

Terminal Block

Connection (Use)	Signal Name	Description	
		AMSR-2C/2DE/ 2FGI/2HJL/2KMO	AMSR-4C/4FGI/ 4HJL/4KMO
DC Reactor for Power Factor Improvement	P1	P1 - P2 is short-circuited by default (the DC reactor cannot be used).★1	
	P2		
Regenerative Converter Brake Unit	N	Not connected.★1	

★1 Contact us when connecting the units.

For the details of CN1, CN2L, and CN6, consult us separately.

Wire Connection Diagram

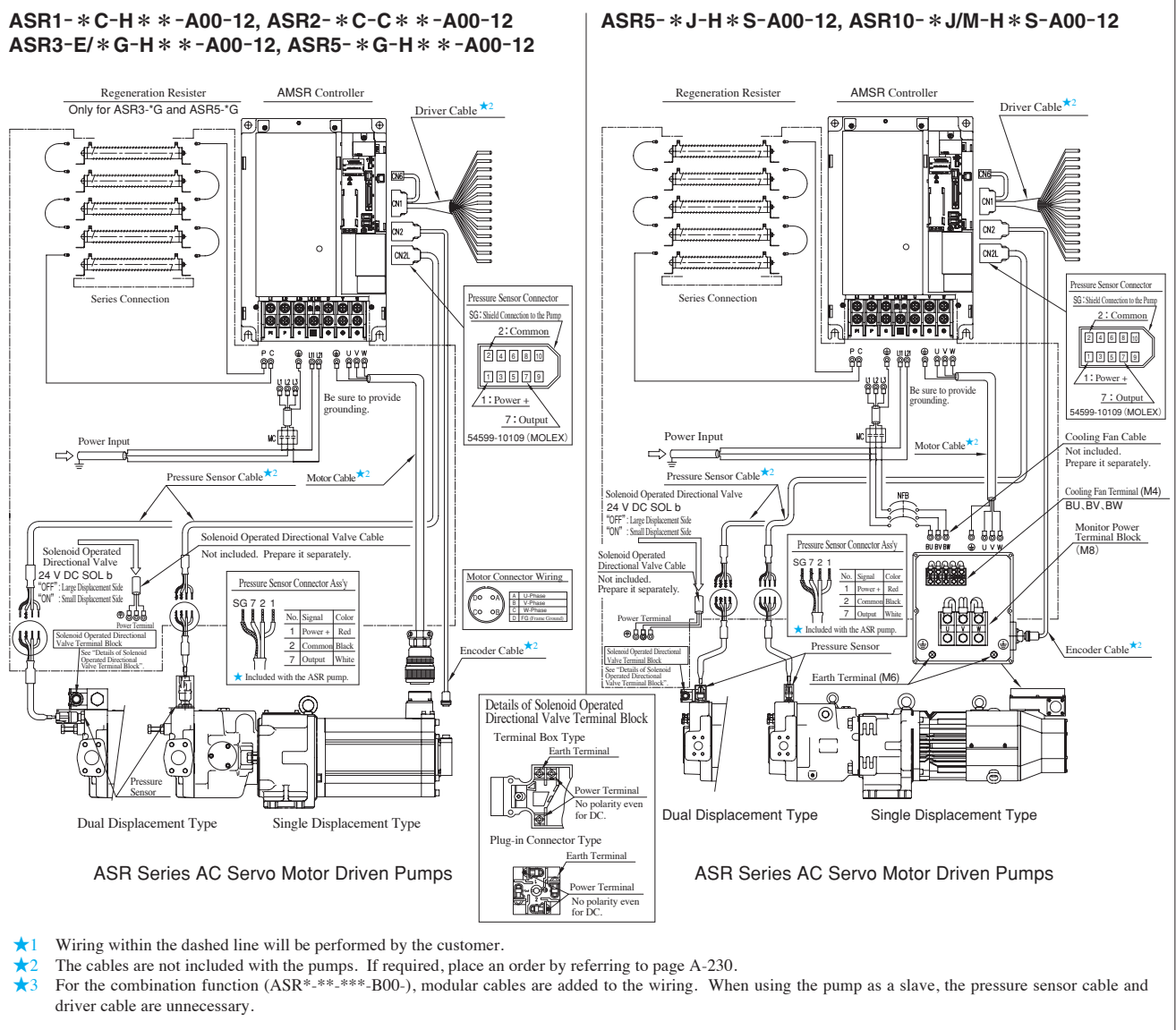

Connectors

	CN1	CN2L	CN6
Housing	10150-3000VE(3M)	54599-1019 (MOLEX)	51004-0300 (MOLEX)
Terminal	-----		-----
Case	10350-52F0-008(3M)		50011-8100 (MOLEX)
Cable	Core Size	AWG # 24 - # 30	AWG # 24 - # 34
	Covered Dia.	1.2-1.5 Dia.	0.8-1.4 Dia.
	Strip Length	2.0-2.5mm	1.2-2.0mm

Motor Cable Plug/Cable Clamp

Model Numbers	Motor Cable Plug		Cable Clamp
	Straight	L-shaped	
ASR 1/ASR 2	MS3106B22-22S	MS3108B22-22S	MS3057-12A
ASR 3- *G	MS3106B32-17S	MS3108B32-17S	MS3057-20A

DDK Ltd.

Wiring Types

Common Wiring

Terminals and Cables	Wiring mm ²
L11 · L21	1.25 (AWG16) *
Pressure Sensor Cable	0.5 (AWG20)

Regeneration Resistor Wiring : 5.5mm² (AWG10) *

Power Classification

Electric Source	Model Numbers	Wiring mm ²	
		Power Input L1, L2, L3 *	Motor Cable U, V, W *
200 V AC 3-Phase	ASR1/ASR2/ASR3-C	5.5 (AWG10)	5.5 (AWG10)
	ASR3-E	8 (AWG8)	8 (AWG8)
	ASR3/ASR5-G	14 (AWG6)	22 (AWG4)
	ASR5/ASR10-J	22 (AWG4)	22 (AWG4)
	ASR10-M	50 (AWG1/0)	30 (AWG2)
400 V AC 3-Phase	ASR1/ASR2/ASR3-4C	5.5 (AWG10)	5.5 (AWG10)
	ASR3/ASR5-4G	8 (AWG8)	8 (AWG8)
	ASR5/ASR10-4J	14 (AWG6)	8 (AWG8)
	ASR10-4M	14 (AWG6)	22 (AWG4)

* Use a 600 V vinyl-insulated cable.

Cable Numbers

The cables are not included with the ASR pumps. If required, place an order by referring to the list below. The cables other than the motor cable are common for all models.

Motor Cable

ASR Pump Model Numbers	Cable Model Numbers	Remarks
ASR 1-*C-H*-*-00-12	YSDC-M1-29-☆-★-10	☆ : Plug Type S : Straight, L : L-shaped ★ : Cable Length 03 : 3 m 05 : 5 m 10 : 10 m 15 : 15 m 20 : 20 m 30 : 30 m N : Plug and cable clamp only
ASR 2-*C-C*-*-00-12		
ASR 3-E-H*-*-00-12	YSDC-M1-44S-☆-★-10	
ASR 3-G-H*-*-00-12	YSDC-M1-1A-☆-★-10	
ASR 3-4G-H*-*-00-12	YSDC-M1-44S-☆-★-10	
ASR 5-G-H*-*-00-12	YSDC-M1-1A-☆-★-10	
ASR 5-4G-H*-*-00-12	YSDC-M1-44S-☆-★-10	

Driver Cable/Encoder Cable/Pressure Sensor Cable

Cable Type	Cable Model Numbers	Remarks
Driver Cable	YSDC-D14-00-★-10	★ : Cable Length 01 : 1 m 02 : 2 m 03 : 3 m 05 : 5 m 10 : 10 m 20 : 20 m
Encoder Cable	YSDC-E7-S-★-10	★ : Cable Length 02 : 2 m 05 : 5 m 10 : 10 m
Pressure Sensor Cable	Consult us separately.	

Regeneration Resister

Specifications

AMSR Controller Model Numbers	Regeneration Resister Model	Qty.	Permissible Regeneration W	Regeneration with Fan W	Resistance Ω	Mass kg
AMSR-2FGI-	GRZG400-1.5Ω	4	500	800	6 (1.5Ω×4)	3.2 (0.8kg×4)
AMSR-2HJL-	GRZG400-0.9Ω	5	850	1300	4.5 (0.9Ω×5)	4.0 (0.8kg×5)
AMSR-2KMO-	GRZG400-0.6Ω				3 (0.6Ω×5)	
AMSR-4FGI-	GRZG400-5.0Ω	4	500	800	20 (5.0Ω×4)	3.2 (0.8kg×4)
AMSR-4HJL-	GRZG400-2.5Ω	5	850	1300	12.5 (2.5Ω×5)	4.0 (0.8kg×5)
AMSR-4KMO-	GRZG400-2.0Ω				10 (2.0Ω×5)	

- ★1. Regeneration Resistors are included with the ASR pumps.
- ★2. Regeneration Resistors may become excessively heated. Use heat-resistant and fireproof wires and avoid their contact with the brakes.

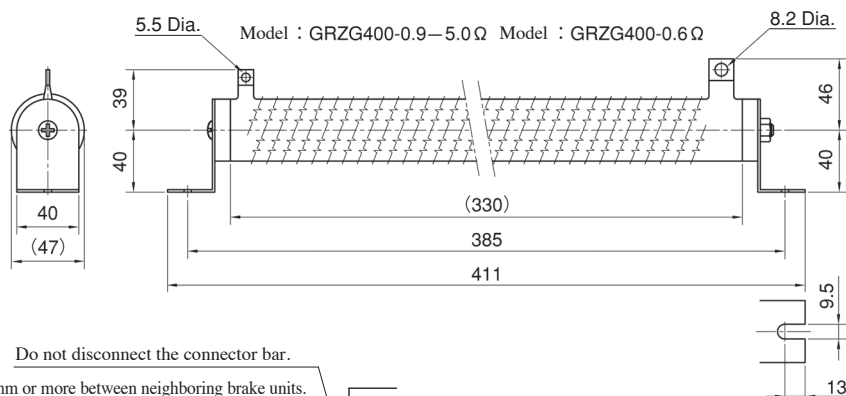

Connection

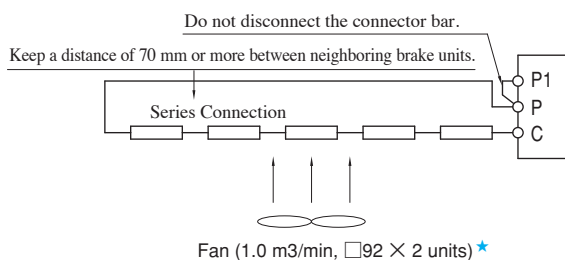

- ★ Recommended fan capacity for fan cooling. In this case, change the setting of parameter No. PA02 from "0000" to "00FA".

ASE Series AC Servo Motor Driven Pumps

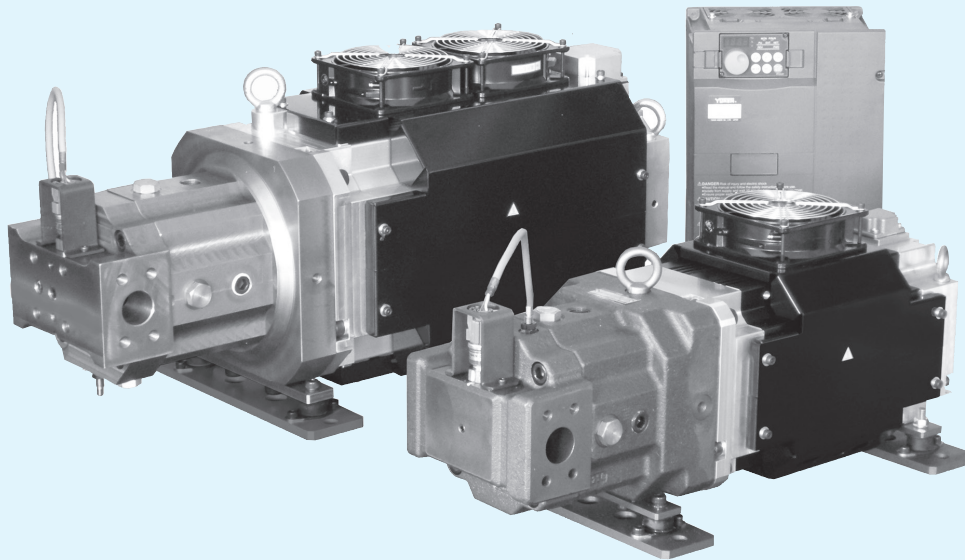

This product is exclusively use for foreign countries outside of Japan.

■ “ASE” Series AC Servo Motor Driven Pumps

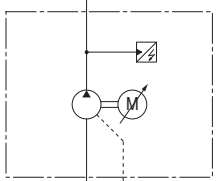
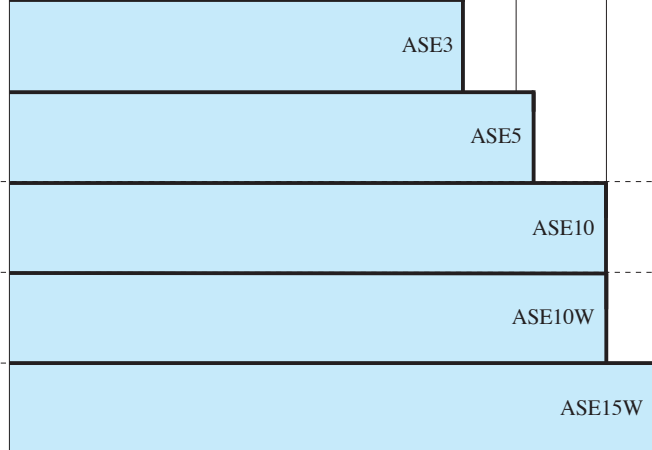
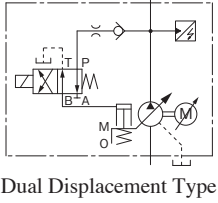
Pump Type	Graphic Symbols	Geometric Displacement cm ³ /rev					Maximum Operating Pressure MPa	Page
		0	2	5	10	20		
ASE Series AC Servo Motor Driven Pumps	 Single Displacement Type						17.5	A-234
	 Dual Displacement Type							

■ AMSE Controller A-244

Hydraulic Fluids

Hydraulic Fluids

Use clean petroleum base oils equivalent to ISO VG32 or 46. The recommended viscosity range is from 20 to 400 mm²/s and temperature range is from 0 to 60 °C, both of which have to be satisfied for the use of the above hydraulic oils.

Control of Contamination

Due caution must be paid to maintaining control over contamination of the operating oil which can otherwise lead to breakdowns and shorten the life of the unit. Please maintain the degree of contamination within NAS class 9.

The suction port must be equipped with at least 100 μm (150 mesh) reservoir type filter and the return line must have a line type filter of under 10 μm.

Instructions

Transportation

For transportation, use the lifting rings on the pump. Do not use lifting cables at places other than the lifting rings.

Mounting

When installing the pump, the filling port should be positioned upwards.

Suction Pressure

Permissible suction pressure at the inlet port of the pump is between -16.7 and +50 kPa. For piping to the suction port, use pipes of the nominal diameters shown below. Make sure that the height of the pump suction port is lower than the oil level in the reservoir.

Model	Nominal Dia.
ASE3/ASE5	1 1/2
ASE10	2 1/2
ASE10W	2
ASE15W	3

Hints on Piping

When using steel pipes for the suction or discharge ports, excessive load from the piping to the pump generates excessive noise. Whenever there is fear of excessive load, please use rubber hoses.

Drain Piping

Install drain piping according to the chart and ensure that pressure within the pump housing should be maintained at a nominal pressure of less than 0.1 MPa and surge pressure of less than 0.5 MPa.

The length of piping should be less than 1 m. Instead of joining the drain pipe to other return lines, run it independently. The pipe end should be submerged in oil.

[Recommended Drain Piping Size]

Model	Fitting Size	Inside Dia. of Pipe
ASE3/ASE5	1/2 (Inside Dia. 12 mm or more)	12 mm or more
ASE10/ASE10W/ASE15W	3/4 (Inside Dia. 16 mm or more)	19 mm or more

Precautions

This pump does not have a full cut-off function.

Be sure to install an external relief valve for setting the PH pressure (maximum circuit pressure) in the pump discharge line.

Starting

Before first starting, fill the pump case with clean operating oil via the filling port. In order to avoid air blockage when first starting, adjust the control valves so that the discharged oil from the pump is returned directly to the reservoir or the actuator moves in a free load.

Bleeding Air

It may be necessary to bleed air from the pump case and lines to remove causes of vibration. An air bleed valve (Model Number: ST1004, Page A-259) in the outlet line is recommended.

For air bleeding with an air bleed valve installed, run the pump at a rotational speed that provides a flow rate equal to/higher than the valve's flow rate to reseating.

Setting Delivery

At the time of shipment, the unit has been preset to the delivery rate shown below.

[Default Setting of Delivery]

Model Numbers	Single Displacement Type cm ³ /rev	Dual Displacement Type "W" cm ³ /rev	
		Large Displacement	Small Displacement
ASE3	32.3	—	
ASE5	57.7	—	
ASE10	102.7	—	
ASE10W	—	100	58
ASE15W	—	151	100

Precautions During Operation

During and for a period after operation, the surface temperature of the AC servo motor and the pump will be hot. Prevent hands and other body parts from coming into contact with them.

[Volume of Pre-fill Oil Required]

Model	Volume cm ³
ASE3/ASE5	600
ASE10	900
ASE10W	2200
ASE15W	3100

Adjustment of Delivery

There is no flow adjustment screw for the single displacement type. Tuning the large displacement side flow adjustment screw for the dual displacement type clockwise decreases the delivery. Turning the small displacement side flow adjustment screw for the dual displacement type clockwise increases the delivery.

[Volume adjusted by each full turn of the flow adjustment screw]

Model Numbers	Dual Displacement Type "W" cm ³ /rev	
	Large Displacement	Small Displacement
ASE10W	5.3	7.4
ASE15W	7.2	9.6

★ For the relationship between the flow adjustment screw position and flow adjustment, see pages A-237.

Providing flexible flow/pressure control !

ASE Series AC Servo Motor Driven Pumps

The ASE series pumps inherit the basic concept of the shaft speed control from the ASR series pumps and offer high cost performance. The pumps of this series offer easy shaft speed control for systems that do not require as much precision, response, or repeatability as the ASR series pumps offer.

System Configuration

A feedback loop is formed by the AMSE controller that computes deviations between control signals from the machine side (speed and pressure commands) and sensor signals to drive the AC servo motor accordingly. Control parameters can be set digitally by using dedicated software.

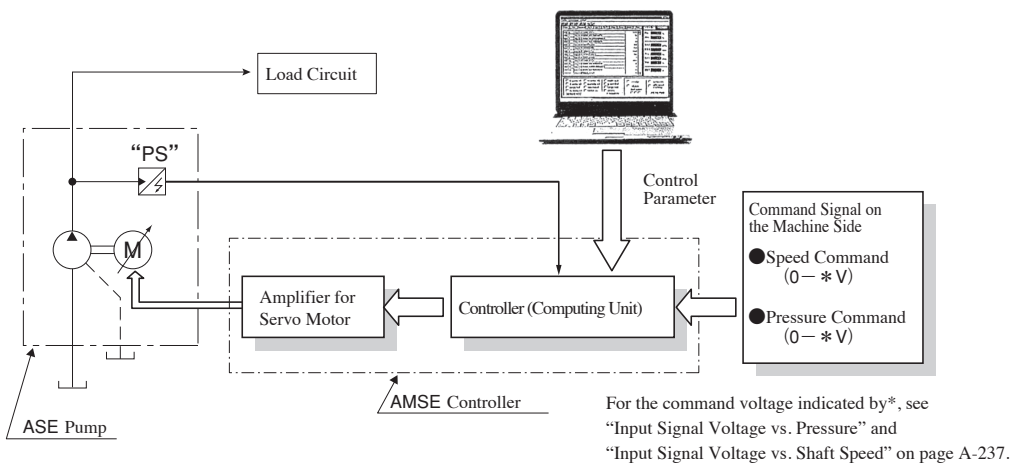
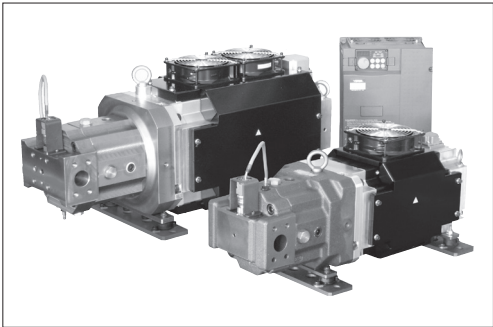

Graphic Symbols

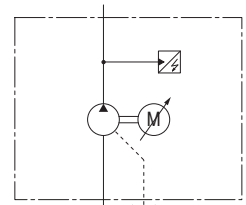

Single Displacement Type ASE *

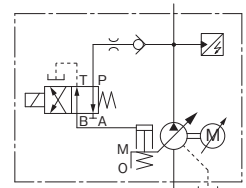

Dual Displacement Type ASE *W

- **Energy saving with low heat generation**
These pumps run at a rotational speed suitable for mechanical requirements, eliminating unnecessary power loss. They minimize heat generation in the fluid and allow the use of a significantly smaller reservoir.
- **Low noise**
Noise reduction insulation included as standard.
- **Less wiring / high reliability**
Uses sensor-less rotational speed control.
- **Digital AMSE controller that saves space and wiring**
The integration of the amplifier for the servo motor and the controller saves space and wiring. The parameters can be digitally adjusted in an easy and repeatable way.
- **Dual displacement type for a wider operation range**
The dual displacement type has a solenoid operated directional valve to switch between large and small swash plate angles. A single pump unit of the dual displacement type can operate both with low pressure/large flow and with high pressure/small flow. Thus, in comparison to the single displacement type with the same motor capacity, the dual displacement type covers a significantly wider range of operating pressures and flow rates.
- **Large flow**
The AMSE controller has a combination function that supports operation with large flow up to 4800 L/min (ASE15W × 16 units).

Specifications

Descriptions		Model Numbers					
		ASE3	ASE5	ASE10	ASE10W	ASE15W	
Power Capacity		AA	BZ	CE	BZ	CE	
Pump	Flow Control	Max. Flow	80.8 L/min	132.7 L/min	205.4 L/min	200 L/min	302 L/min
		Min. Adj. Flow	2 %				
		Hysteresis	1 % or less				
		Repeatability	1 % or less				
		Input Signal Voltage	64.6 L/min/5V	115.4 L/min/5V	205.4 L/min/5V	200 L/min/5V	302 L/min/5V
	Max. Permissible Input Signal Voltage*1	80.8 L/min/6.25V	132.7 L/min/5.75V				
	Pres. Control	Max. Operating Pres.	17.5 MPa			17.5 MPa (21 MPa)*2	
		Min. Adj. Pres.	0.1 MPa				
		Hysteresis	1 % or less				
		Repeatability	1 % or less				
Input Signal Voltage		17.5 MPa/5V			17.5 MPa/5V		
Max. Permissible Input Signal Voltage*1				21 MPa/6V			
AC Servo Motor Specifications	Rated Output	11 kW	20 kW	35 kW	20 kW	35 kW	
	Insulation Class	Class F					
	Cooling System	Totally-enclosed Fan-cooling					
	Cooling Fan Power Consumption	20W(50Hz)/18W(60Hz)	40W(50Hz)/36W(60Hz)	60W(50Hz)/54W(60Hz)	40W(50Hz)/36W(60Hz)	60W(50Hz)/54W(60Hz)	
	Environmental Condition	0 - +40 °C (No Freezing)					
Ambient Humidity	80 %RH or less (No Condensation)						
Mass	200 V AC Type	75 kg	123 kg	185 kg	180 kg	—	
	400 V AC Type	79 kg	116 kg	180 kg	173 kg	231.5 kg	
Applicable Controller Model Number		AMSE-*AE**-10	AMSE-*BB**-11	AMSE-*DE**-10	AMSE-*BB**-11	AMSE-*DE**-10	

*1. By adjusting the controller, the maximum flow rate/5 V (80.8 L/min/5 V) and the maximum operating pressure/5 V (21 MPa/5 V) can be set.

*2. Depending on the value of geometric displacement.

Model Number Designation

The model numbers below indicate packages each containing an AC servo motor driven pump, AMSE controller, and Regeneration Resistors.

ASE10W	-4	BZ	-G	W	S	A100	N	-B	00	-20
Series Number *1	Power Supply Voltage	Power Capacity *2	Max. Operating Pres.	Max. Flow	Port Direction	Coil Type for Solenoid Operated Directional Valve	Electrical Conduit Connection for Solenoid Operated Directional Valve	Function Selection	Parameter Number	Design Number
ASE3	None: 200 V AC	AA	G:17.5 MPa (21 MPa) *3	80: 80.8 L/min	S:Horizontal B:Vertical	—	—	B: Combination (Single Use Allowed)*4	00: Standard	40
ASE5		BZ		130: 132.7 L/min						40
ASE10		CE		200: 205.4 L/min						30
ASE10W	4: 400 V AC	BZ	G:17.5 MPa (21 MPa) *3	W:User Setting *100/58*5 Large Flow (Sol OFF) 100 cm ³ /rev (200 L/min) Small Flow (Sol ON)*6 58 cm ³ /rev (133 L/min)	S:Horizontal B:Vertical	AC A100:100 V AC A120:120 V AC A200:200 V AC A240:240 V AC	None: Terminal Box	B: Combination (Single Use Allowed)*4	00: Standard	20
ASE15W	4:400 V	CE		W:User Setting *151/100*5 Large Flow (Sol OFF) 151 cm ³ /rev (302 L/min) Small Flow (Sol ON) 100 cm ³ /rev (200 L/min)		DC None:24 V DC D12:12 V DC D48:48 V DC D100:100 V DC D110:110 V DC D200:200 V DC D220:220 V DC				N: DIN Plug-in Connector
						AC(AC⇔DC) R100:100 V AC R110:110 V AC R200:200 V AC R220:220 V AC				

*1. To order an AC servo motor driven pump separately for spare use, prefix "N-" to the model number and omit the Function Selection and Parameter Number.

Example) N-ASE10W-4BZ-GWSA100N-20

*2. For the relationship between the power capacity and the pressure/flow in terms of specification limits, see charts on page A-238.

*3. For the models ASE10W/ASE15W, it depends on the value of geometric displacement.

*4. For combination operation, consult us separately regarding the types of hydraulic circuits, components, and electric cables.

*5. Ex. The factory-adjusted value can be set to 70/40.[70: 70 cm³/rev (Large Flow) and 40: 40cm³/rev. (Small Flow)]

*6. The maximum revolutions can reach to 2300 r/min if the pump capacity is set to less than 60 cm³/rev.

■ Solenoid Ratings

See Solenoid Ratings (page A-51).

■ Pipe Flange Kit

No pipe flange kit is included with the pump. The pipe flange kits below are available if required. For the details of the pipe flange kits, see pages A-258 and A-259.

Pump Model Numbers	Name of Port	Pipe Flange Kit Numbers		
		Threaded Connection	Socket Welding	Butt Welding
ASE3 ASE5	Suction	F5-12-A-10	F5-12-B-10	F5-12-C-10
	Discharge	F5-10-A-10	—	F5-10-C-10
ASE10	Suction	F5-20-A-10	F5-20-B-10	F5-20-C-10
	Discharge	F5-10-A-10	—	F5-10-C-10
ASE10W	Suction	F5-16-A-10	F5-16-B-10	F5-16-C-10
	Discharge	F5-10-A-10	—	F5-10-C-10
ASE15W	Suction	F5-24-A-10	F5-24-B-10	F5-24-C-10
	Discharge	F5-12-A-10	—	F5-12-C-10

Characteristics of Single Displacement Type

Input Signal Voltage vs. Pressure

● ASE3/ASE5/ASE10

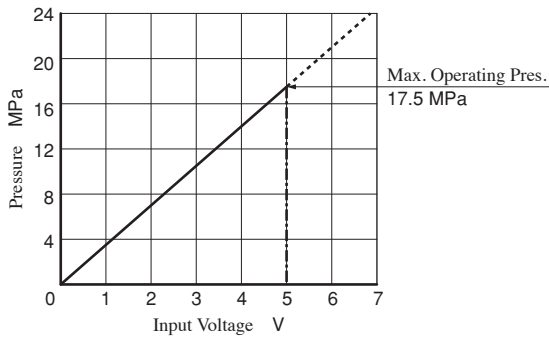

● ASE10W/ASE15W

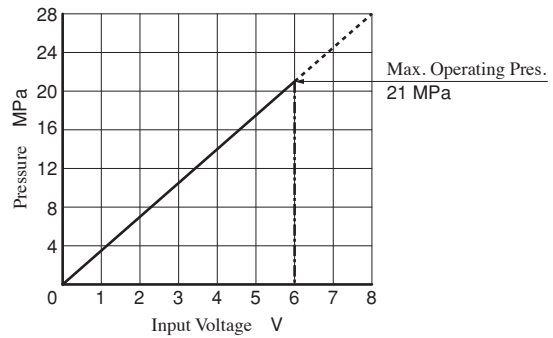

★ Do not input a voltage higher than the level corresponding to the maximum operating pressure.

Input Signal Voltage vs. Shaft Speed

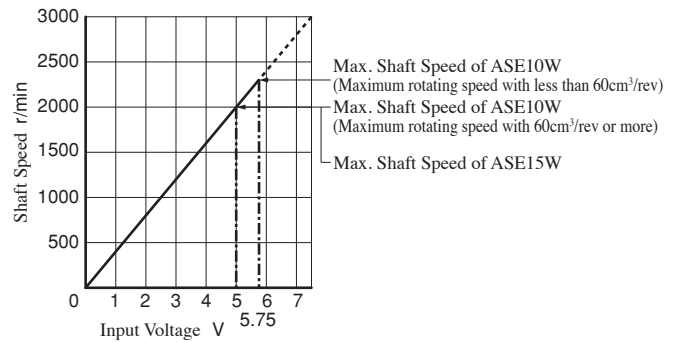
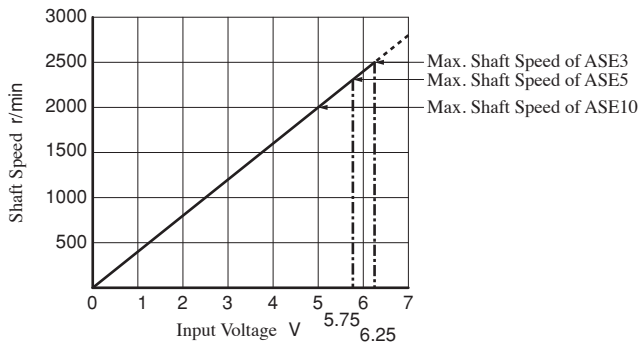

★ Do not input a voltage higher than the level corresponding to the maximum shaft speed.

Flow Adjustment Screw Projection and Geometric Displacement

● ASE10W

Large displacement (SOL:OFF)

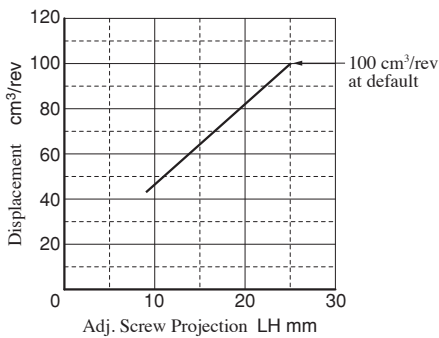

Small displacement (SOL:ON)

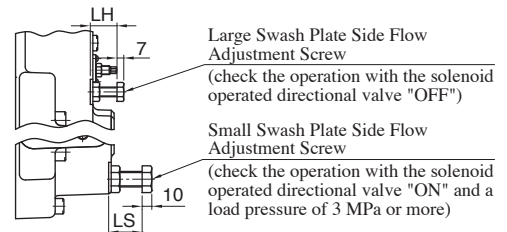
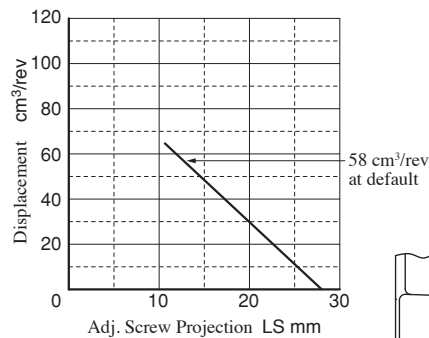

● ASE15W

Large displacement (SOL:OFF)

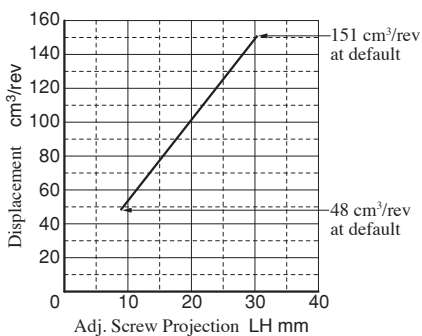

Small displacement (SOL:ON)

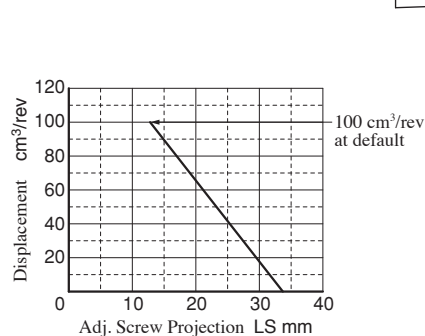

Pressure vs. Discharge Flow (Reference)

----- Max Continuous Operation Time: 60 sec.

● ASE3- *AA-G80* -

Pressure enabling continuous operation: 11 MPa or less

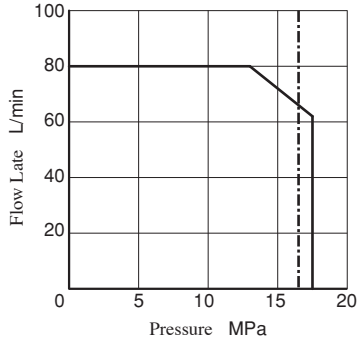

● ASE5- *BZ-G130* -

Pressure enabling continuous operation: 11 MPa or less

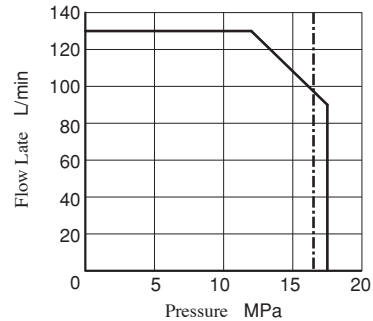

● ASE10-CE-G200* -

Pressure enabling continuous operation: 10 MPa or less

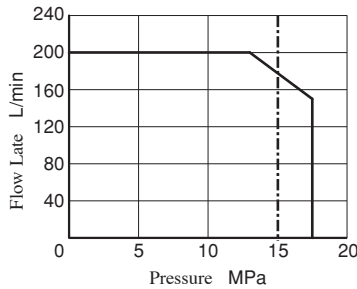

● ASE10-4CE-G200* -

Pressure enabling continuous operation: 11 MPa or less

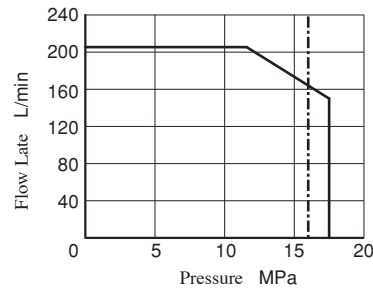

● ASE10W- *BZ-G* * * * -

Pressure vs. delivery characteristics with 100cm³/rev at the large swash plate side and 58cm³/rev at the small swash plate side
 Pressure enabling continuous operation is 6 MPa for the large swash plate side and 11 MPa for the small swash plate side.

100cm³/rev at the large swash plate side

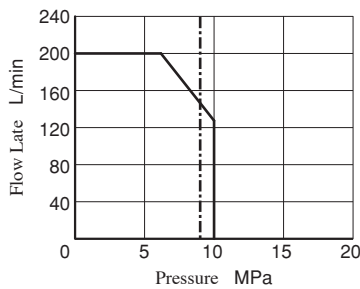

58cm³/rev at the small swash plate side

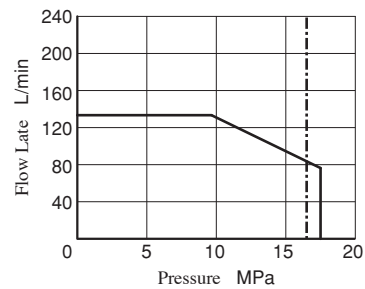

● ASE15W-4CE-G* * * * -

Pressure vs. delivery characteristics with 151cm³/rev at the large swash plate side and 100cm³/rev at the small swash plate side
 Pressure enabling continuous operation is 7 MPa for the large swash plate side and 11 MPa for the small swash plate side.

151cm³/rev at the large swash plate side

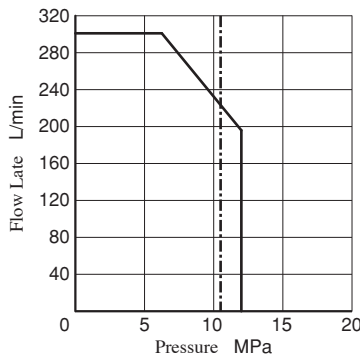

100cm³/rev at the small swash plate side

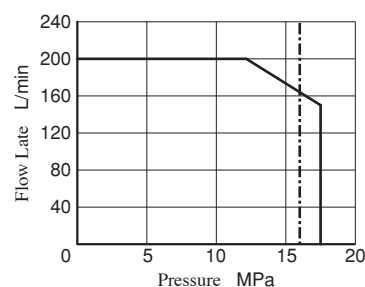

ASE3-AA- ** S- (Horizontal Port Type)

Single Displacement Type

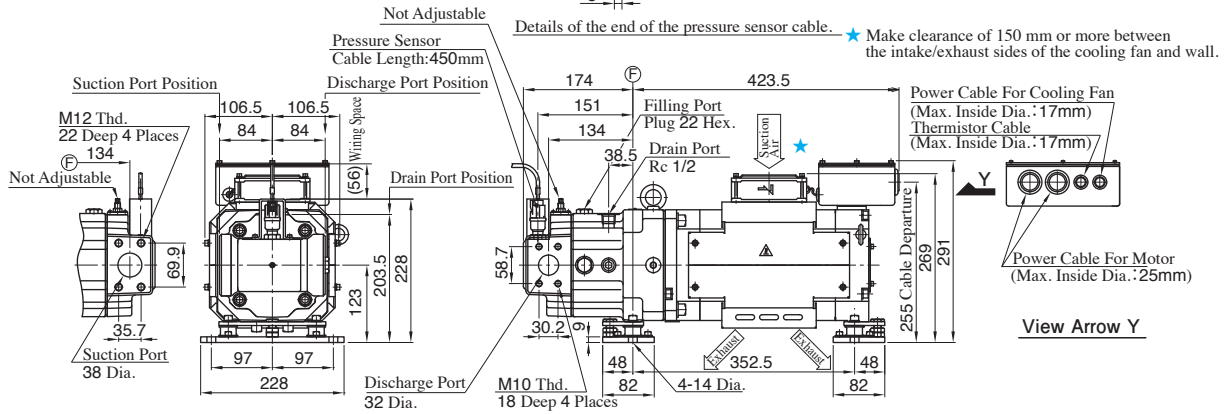

ASE3-AA- ** B- (Vertical Port Type)

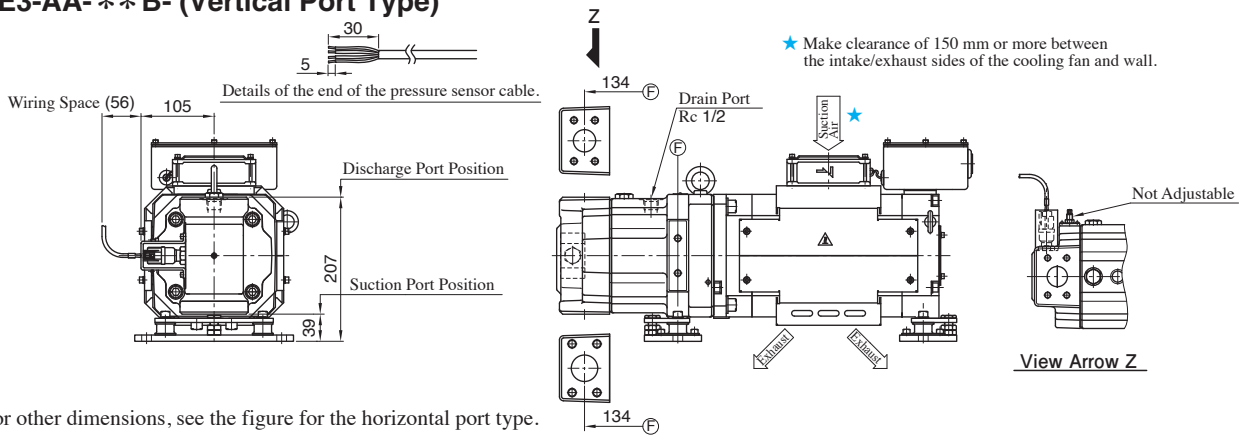

● For other dimensions, see the figure for the horizontal port type.

ASE3-4AA- ** S- (Horizontal Port Type)

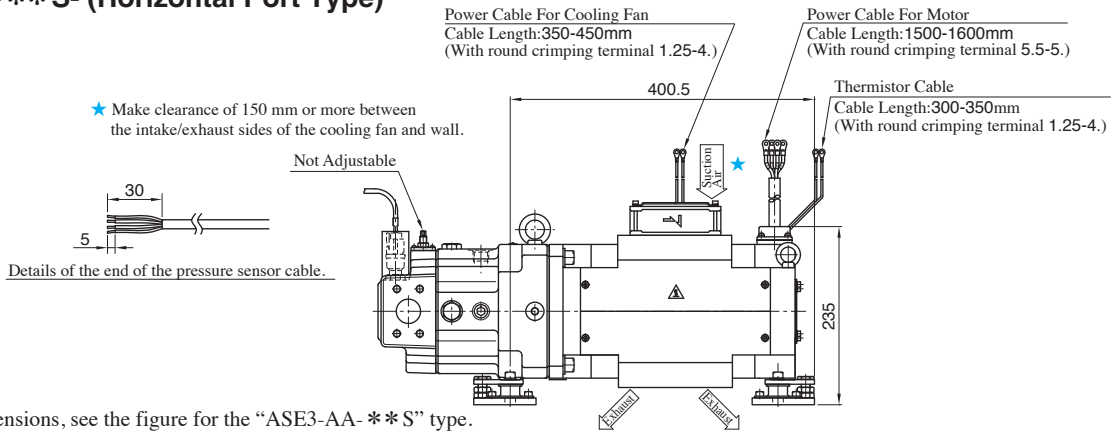

● For other dimensions, see the figure for the "ASE3-AA- ** S" type.

ASE3-4AA- ** B- (Vertical Port Type)

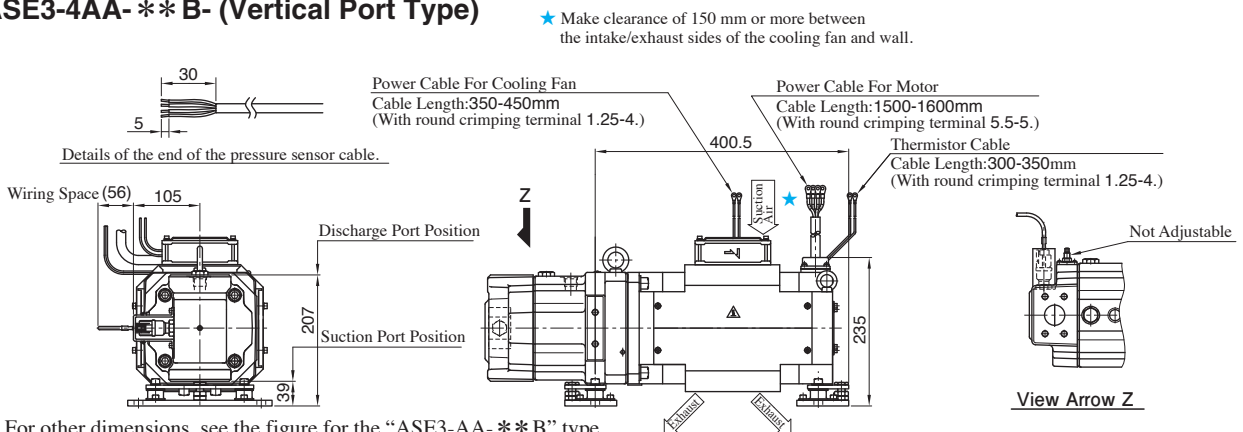

● For other dimensions, see the figure for the "ASE3-AA- ** B" type.

ASE5-BZ- ** S- (Horizontal Port Type)

Single Displacement Type

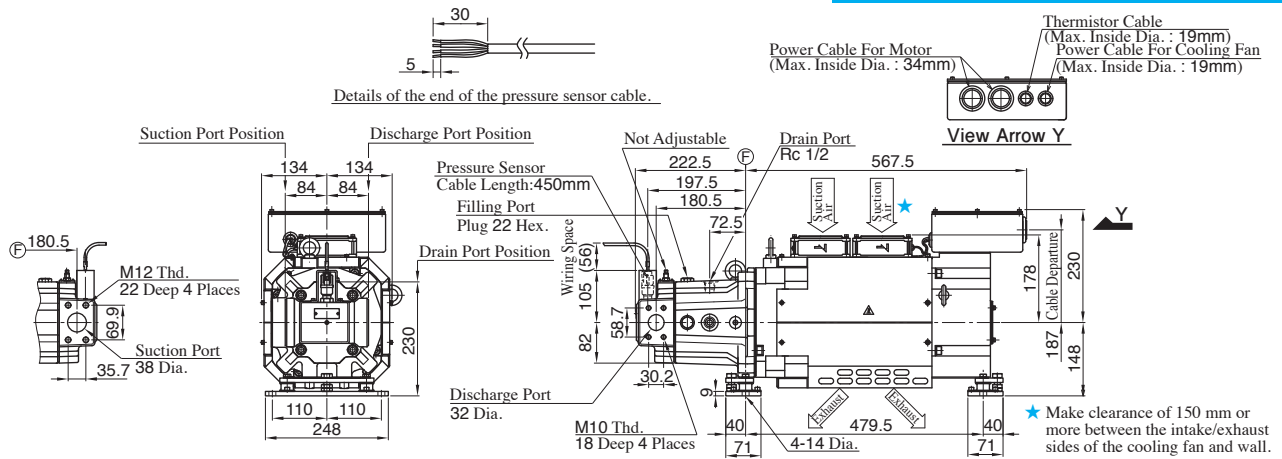

ASE5-BZ- ** B- (Vertical Port Type)

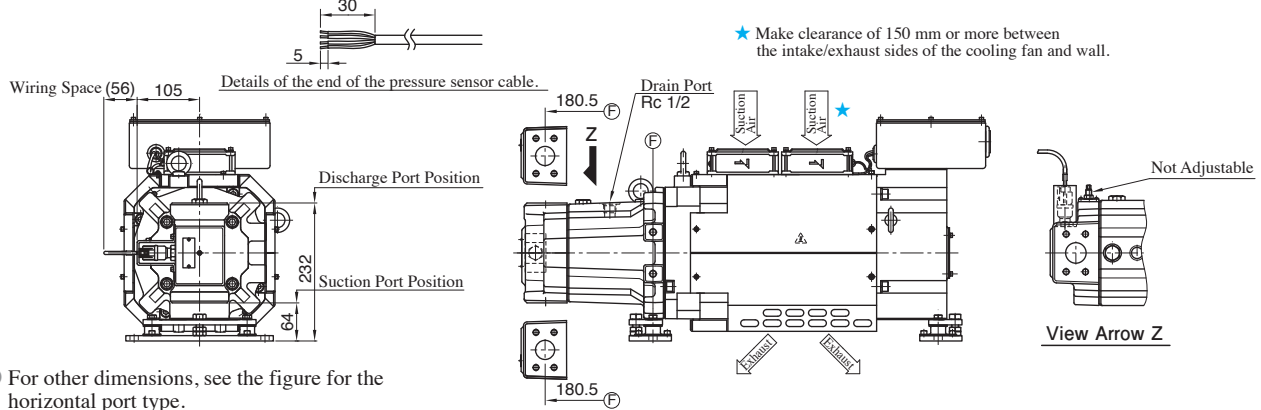

● For other dimensions, see the figure for the horizontal port type.

ASE5-4BZ- ** S- (Horizontal Port Type)

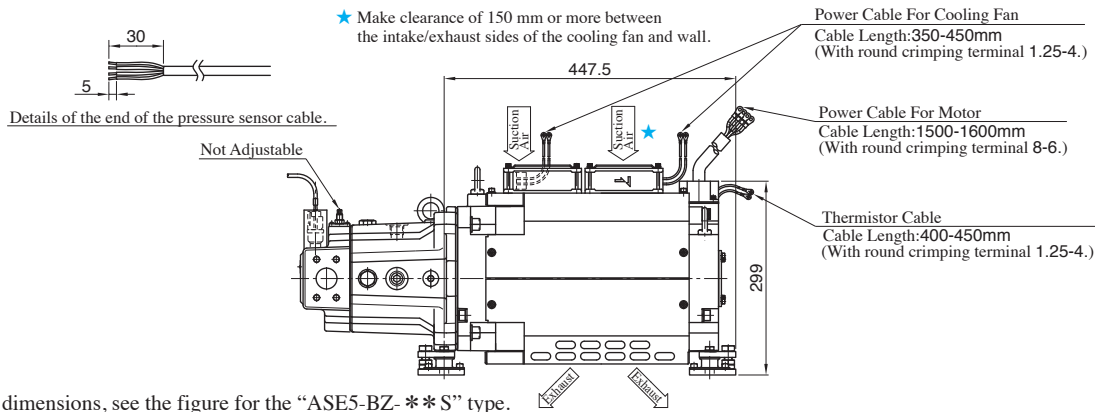

● For other dimensions, see the figure for the "ASE5-BZ- ** S" type.

ASE5-4BZ- ** B (Vertical Port Type)

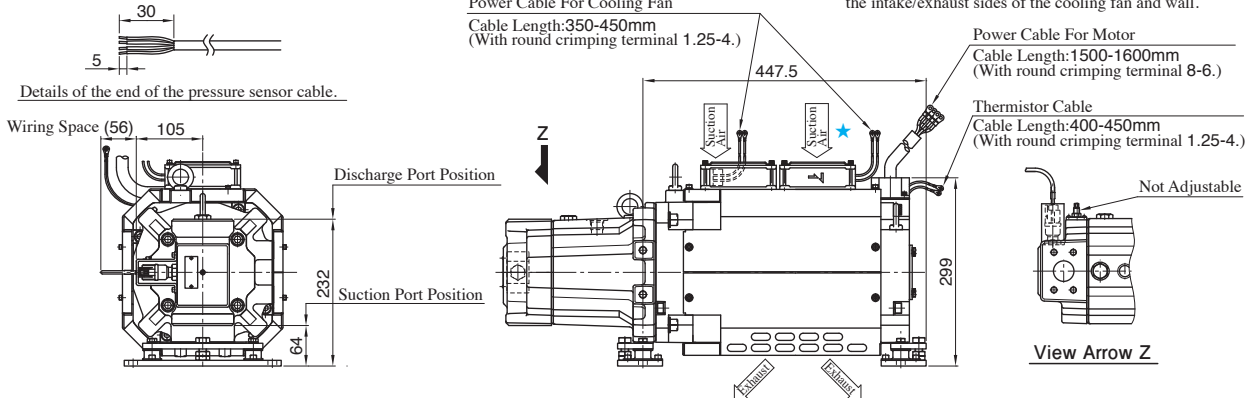

● For other dimensions, see the figure for the "ASE5-BZ- ** B" type.

ASE10-CE- ** S- (Horizontal Port Type)

Single Displacement Type

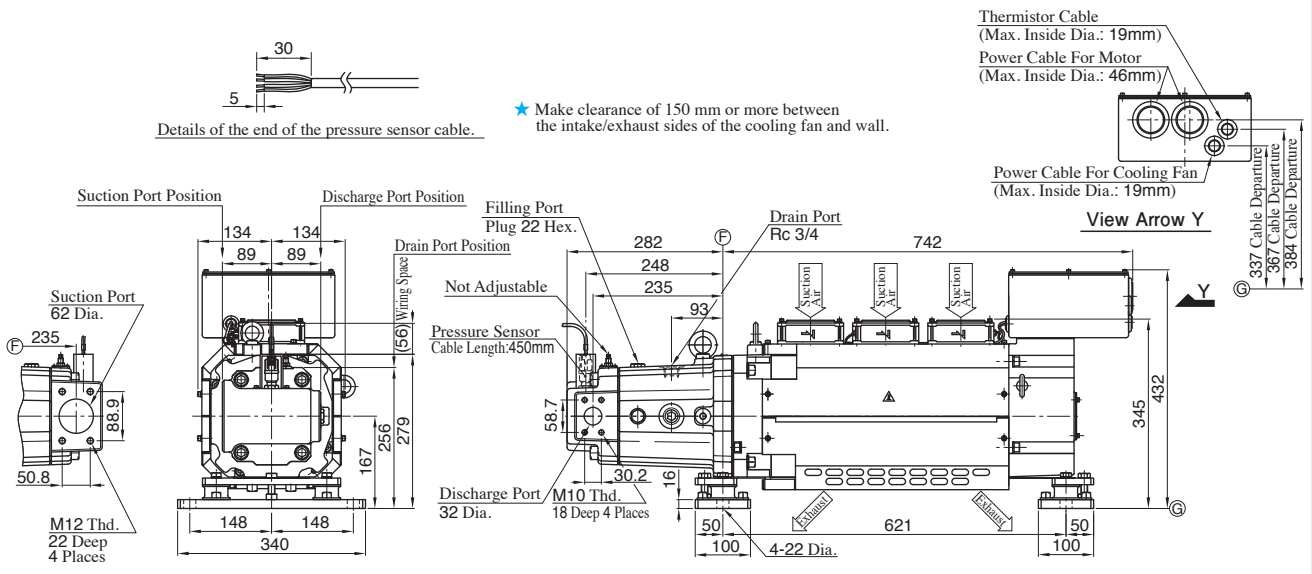

ASE10-CE- ** B- (Vertical Port Type)

★ Make clearance of 150 mm or more between the intake/exhaust sides of the cooling fan and wall.

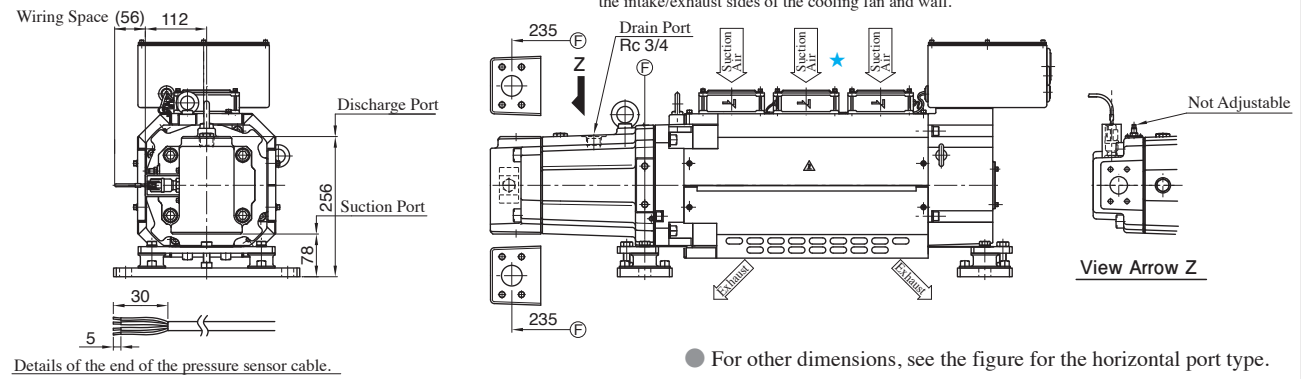

ASE10-4CE- ** S- (Horizontal Port Type)

★ Make clearance of 150 mm or more between the intake/exhaust sides of the cooling fan and wall.

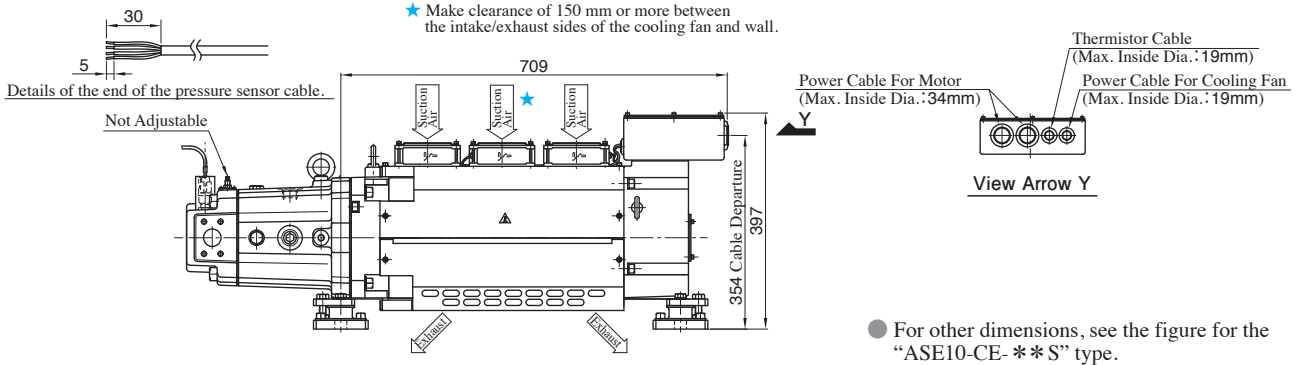

ASE10-4CE- ** B (Vertical Port Type)

★ Make clearance of 150 mm or more between the intake/exhaust sides of the cooling fan and wall.

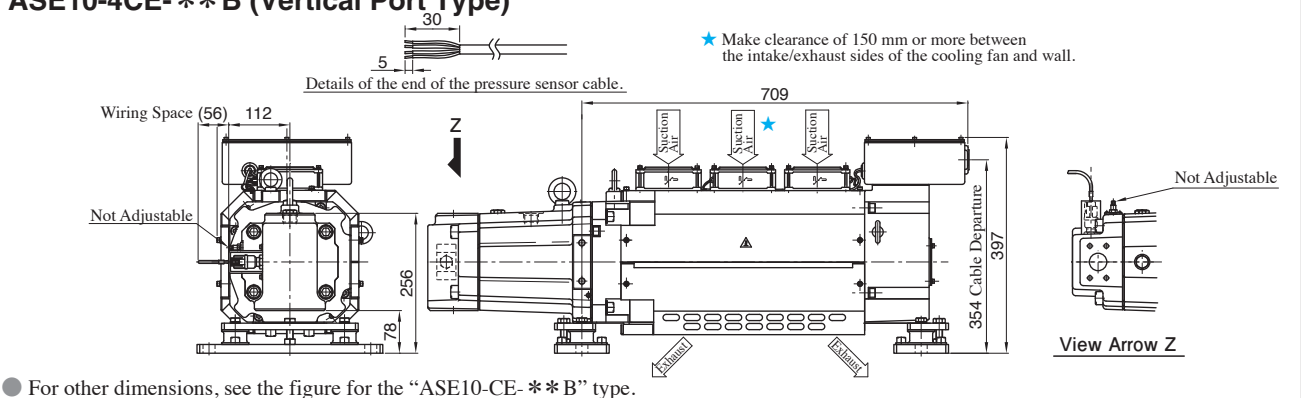

ASE10W-BZ-G * S * * - (Horizontal Port Type)

Dual Displacement Type

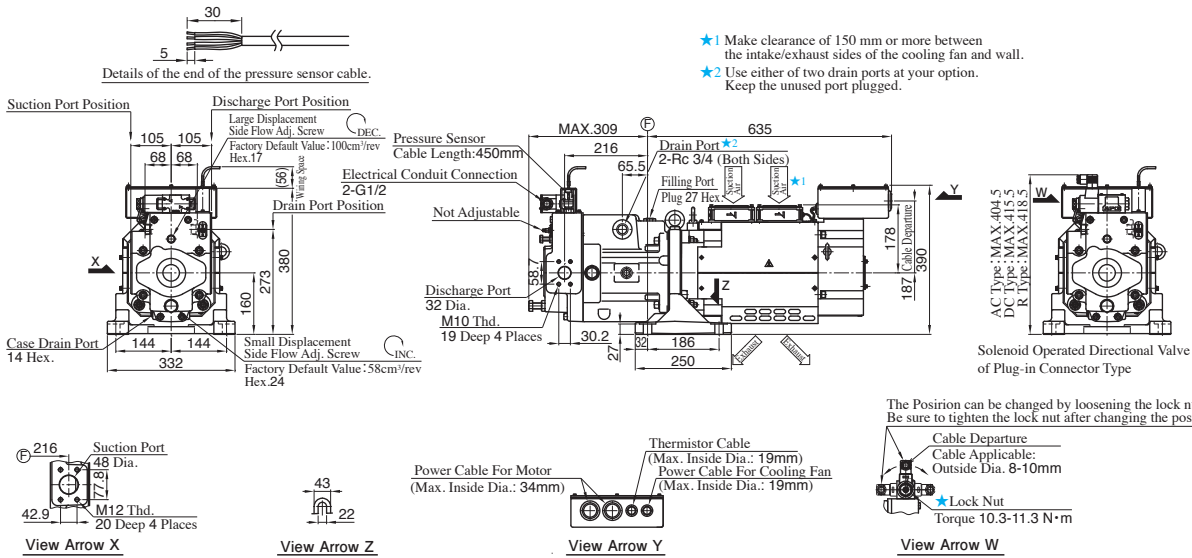

ASE10W-BZ-G * B * * - (Vertical Port Type)

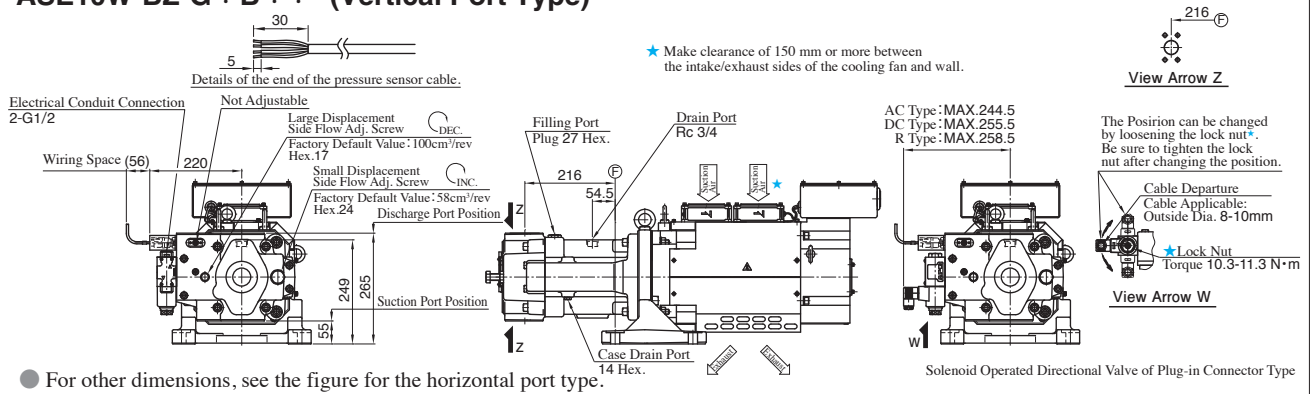

ASE10W-4BZ-G * S * * - (Horizontal Port Type)

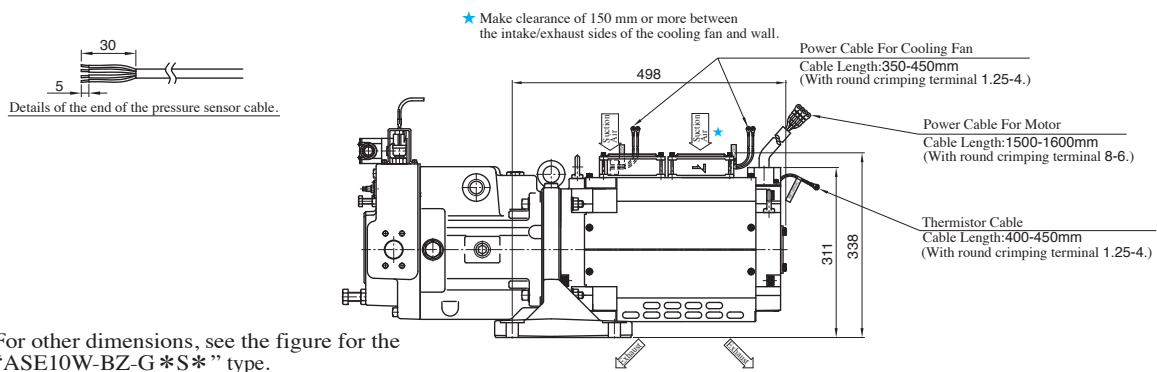

ASE10W-4BZ-G * B * * - (Vertical Port Type)

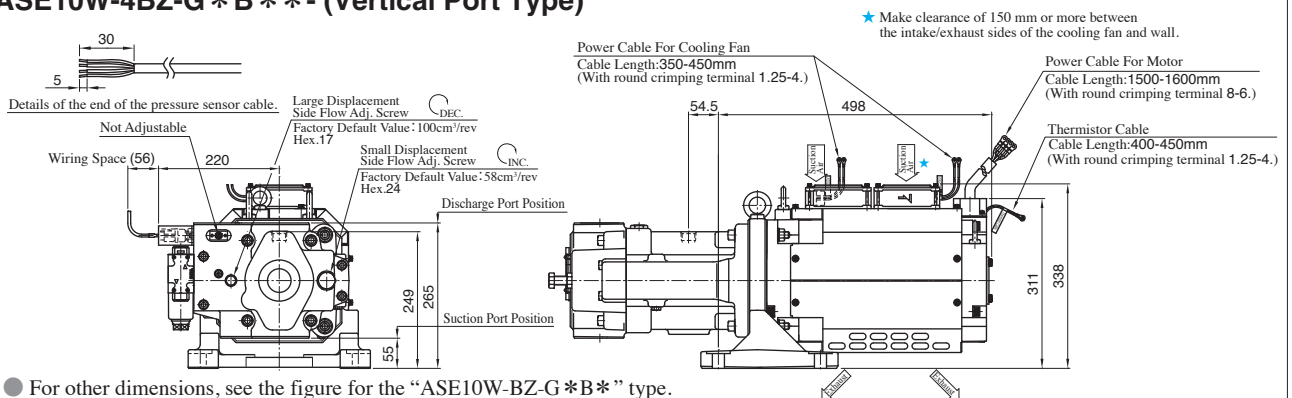

ASE15W-4CE-G * S * * - (Horizontal Port Type)

Dual Displacement Type

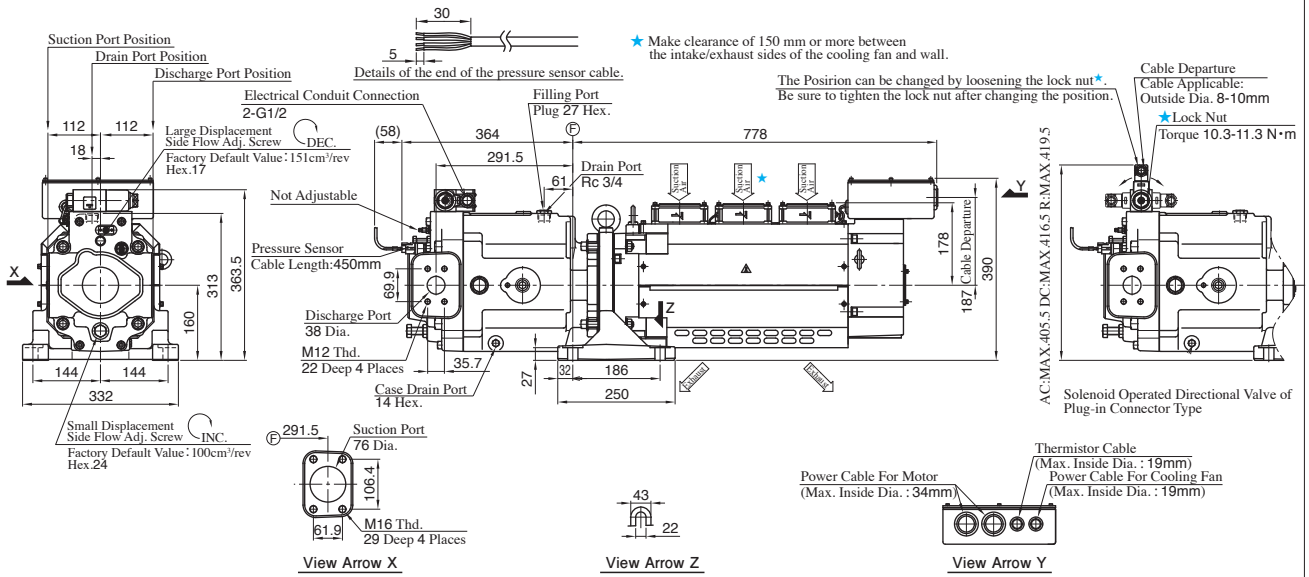

ASE15W-4CE-G * B * * - (Vertical Port Type)

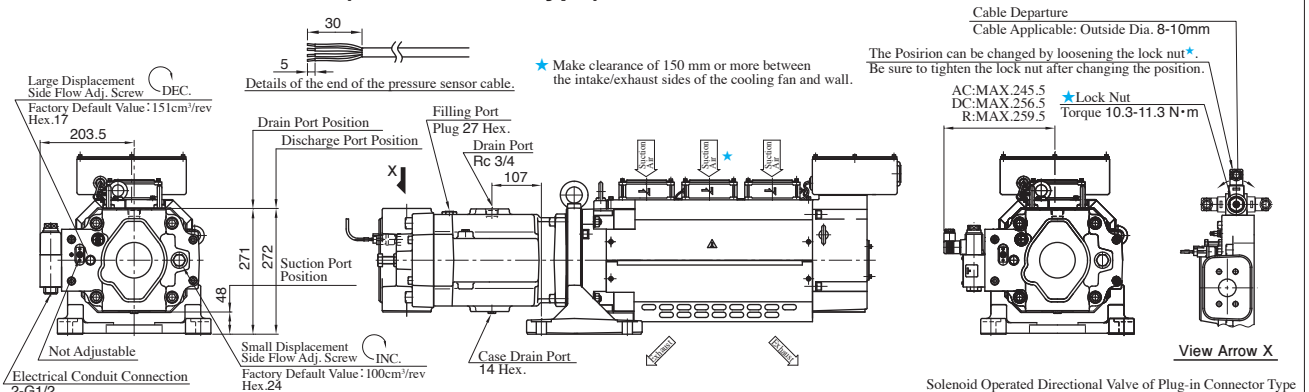

● For other dimensions, see the figure for the horizontal port type.

AMSE Controller

The AMSE controller is used to drive ASE series AC servo motor driven pumps. With an optimal design for the ASE pumps, the controller can maximize the pump performance. The AMSE controller is included with the ASE series pumps.



Specifications

Model Numbers	AMSE- * AE- * * -10		AMSE- * BB- * * -11		AMSE- * DE- * * -10	
	2AE	4AE	2BB	4BB	2DE	4DE
Command Signal Input Voltage	0 - +5 V DC/RATED (MAX. 0 - +10 V)					
Control Method	Vector Control Sensorless					
Monitor Output Voltage	1ch, 0 - +10 V DC					
Digital Monitor	1ch,(FM or Open Collector)					
Sequence Input Signal	12ch.Photo Coupler (Input Resistance : 4.7kΩ) Logic switching is possible by the internal jumper connector (Initial : Sink)					
Voltage At Opening	21-27 V DC					
	Short-Circuited					
Sequence Output Signal	Reray					
	Open Collector					
Voltage/Frequency	200-220 V AC : 50Hz 200-240 V AC : 60Hz 3-Phase	380-480 V AC : 50/60Hz 3-Phase	200-220 V AC : 50Hz 200-240 V AC : 60Hz 3-Phase	380-480 V AC : 50/60Hz 3-Phase	200-220 V AC : 50Hz 200-240 V AC : 60Hz 3-Phase	380-480 V AC : 50/60Hz 3-Phase
Permissible Voltage Fluctuation	170-242 V AC : 50Hz 170-264 V AC : 60Hz 3-Phase	323-528 V AC : 50/60Hz 3-Phase	170-242 V AC : 50Hz 170-264 V AC : 60Hz 3-Phase	323-528 V AC : 50/60Hz 3-Phase	170-242 V AC : 50Hz 170-264 V AC : 60Hz 3-Phase	323-528 V AC : 50/60Hz 3-Phase
Permissible Frequency Fluctuation	Within ±5 %					
Power Supply Capacity*1	28 kVA	27 kVA	41 kVA		80 kVA	
Regeneration Resister (Dynamic Brake)	External Option					
Protection, Cooling	Enclosed Type (IP20), Forced Air Cooling				Open Type (IP00), Forced Air Cooling	
Environmental condition	Ambient Temperature					
	Ambient Humidity					
	Atmosphere					
	Altitude					
	Vibration					
Protective/Warning Functions	Overcurrent · Overvoltage · Inverter Protection Thermal · Motor Protection Thermal · Heatsink Overheat · Instantaneous Power Failure Occurrence · Undervoltage · Input Phase Loss · Motor Overload · Output Side Earth Fault Overcurrent · Output Phase Loss · CPU Fault · Option Fault · Parameter Error · Power Supply Short Circuit · Inrush Current Limit Circuit Fault · Communication Fault · Analog Input Fault · Fan Fault · Overcurrent Stall Prevention · Electronic Thermal Relay Function Prealarm · Regenerative Brake Prealarm · Pu Stop · Brake Transistor Alarm · Parameter Write Error · Copyoperation Error · Operation Panel Lock · Parameter Copy Alarm · Pressure Sensor Disconnection · Network Alarm					
Additional Function	-	Resolver Signal Fault · Overspeed · Speed Deviation Large · Z-Phase Tunning Incomplete	-	Resolver Signal Fault · Overspeed · Speed Deviation Large · Z-Phase Tunning Incomplete	-	Resolver Signal Fault · Overspeed · Speed Deviation Large · Z-Phase Tunning Incomplete
Mass	13kg	7.5kg	14kg	13kg	35kg	
Applicable Pump	ASE3- * AA		ASE5- * BZ ASE10W- * BZ		ASE10- * CE ASE15W-4CE	

*1 The power supply capacity varies with the value of the power supply side inverter impedance (including those of the input reactor and cables).

Model Number Designation

AMSE	-2	AE	-B	00	-10
Series Number	Power Supply Voltage	Amplifier Capacity kW	Function Selection	Parameter Number	Design Number
AMSE : AMSE Controller	2 : 200 V AC 4 : 400 V AC	AE : 15.0	B : Combination (Single Operation Allowed)	00 : Standard	10
		BB : 22.0			11
		DE : 45.0			10

AMSE-2AE-B00-10

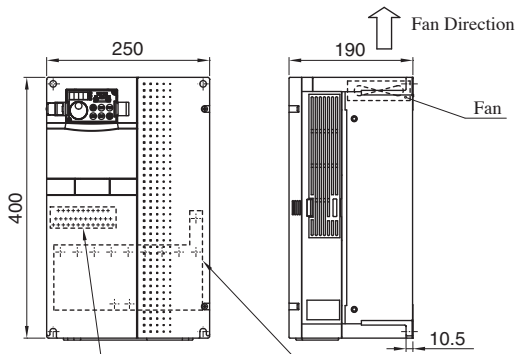

Control Circuit Terminal Assignment (A)



Main Circuit Terminal Assignment (B)

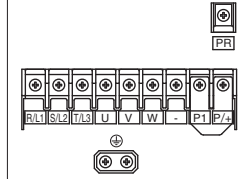

Mountain Hole Dimensions

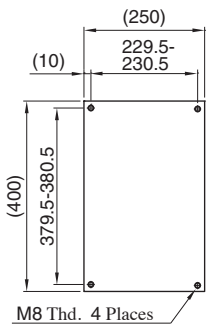

	Main Circuit Terminal R/L1, S/L2, T/L3 U, V, W, P/+, PR, ⊕	Control Circuit Terminal
Terminal Screw	M6	M3.5
Torque [N·m]	4.4	1.2

* Note) Do not connect wiring to the terminals "P1" and "-".

M8 Thd. 4 Places

AMSE-4AE-B00-10

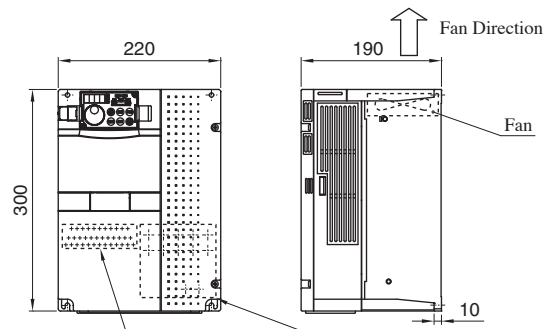

Control Circuit Terminal Assignment (A)



Main Circuit Terminal Assignment (B)

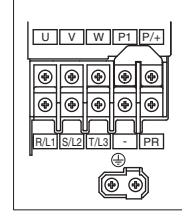

Mountain Hole Dimensions

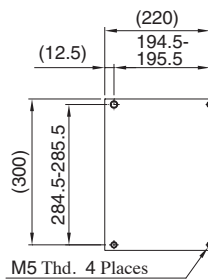

	Main Circuit Terminal U, V, W, P/+, R/L1 S/L2, T/L3, PR, ⊕	Control Circuit Terminal
Terminal Screw	M5	M3.5
Torque [N·m]	2.5	1.2

* Note) Do not connect wiring to the terminals "P1" and "-".

M5 Thd. 4 Places

AMSE-2BB-B00-11

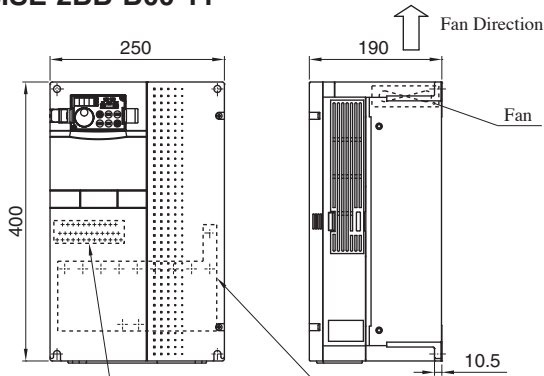

Control Circuit Terminal Assignment (A)

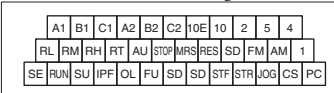

Main Circuit Terminal Assignment (B)

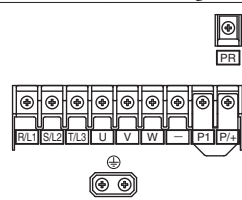

Mountain Hole Dimensions

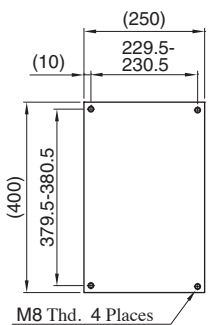

	Main Circuit Terminal R/L1, S/L2, T/L3, U, V, W, P/+, PR, ⊕	Control Circuit Terminal
Terminal Screw	M8	M6 M3.5
Torque [N·m]	7.8	4.4 1.2

* Note) Do not connect wiring to the terminals "P1" and "-".

M8 Thd. 4 Places

AMSE-4BB-B00-11

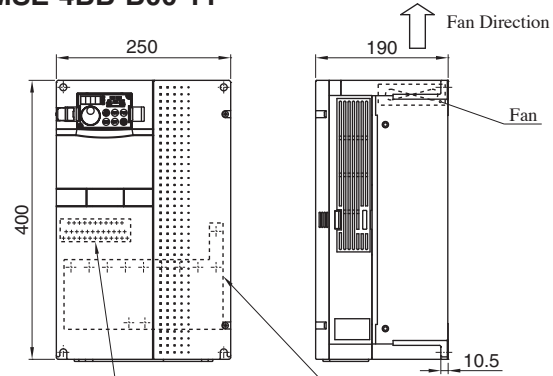

Control Circuit Terminal Assignment (A)

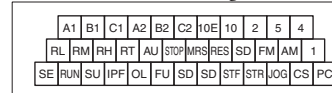

Main Circuit Terminal Assignment (B)

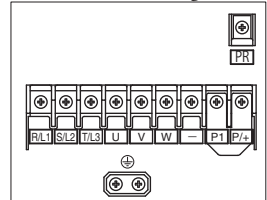

Mountain Hole Dimensions

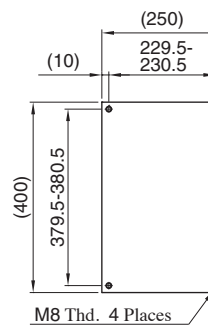

	Main Circuit Terminal R/L1, S/L2, T/L3, U, V, W, P/+, PR, ⊕	Control Circuit Terminal
Terminal Screw	M6	M3.5
Torque [N·m]	4.4	1.2

* Note) Do not connect wiring to the terminals "P1" and "-".

M8 Thd. 4 Places

AMSE- * DE-B00-10

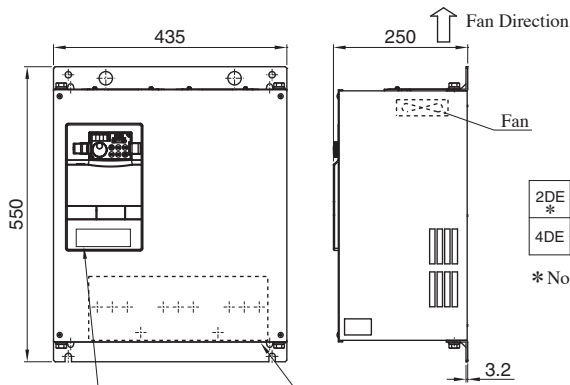

	Main Circuit Terminal U, V, W, P/+ , N/-, R/L1, S/L2, T/L3	Control Circuit Terminal
2DE	Terminal Screw M10	M8 M3.5
*	Torque [N·m] 14.7	7.8 1.2
4DE	Terminal Screw M8	M3.5
	Torque [N·m] 7.8	1.2

* Note) Do not connect wiring to the terminals "P1".

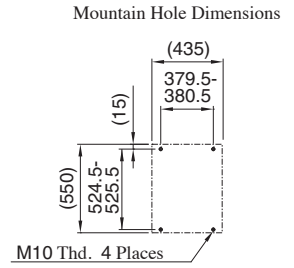

Control Circuit Terminal Assignment (A)

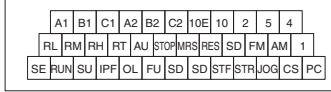

Main Circuit Terminal Assignment (B)

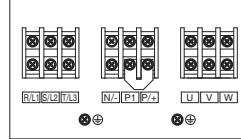

Installation Standard

AMSE-2AE- * BB-B00- * *

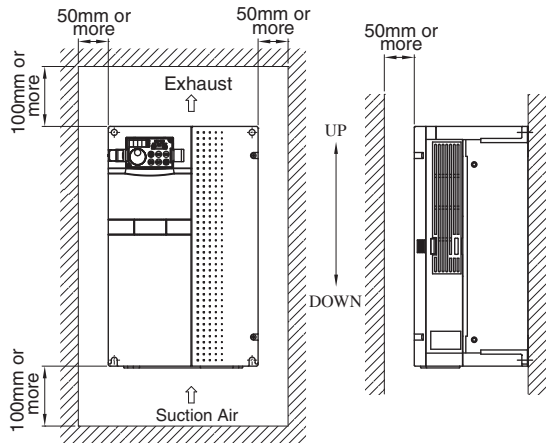

AMSE-4AE-B00-10

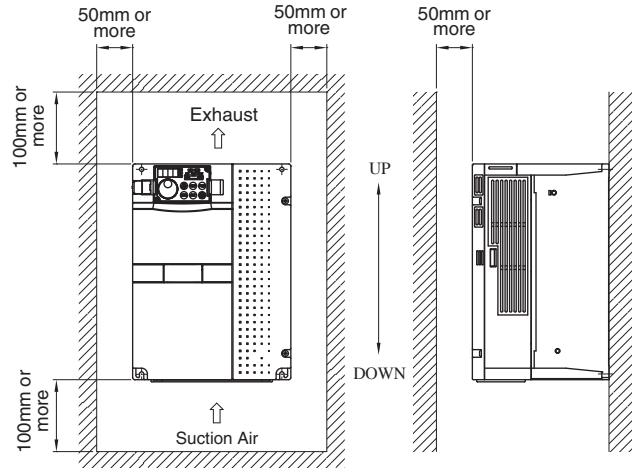

AMSE- * DE-B00-10

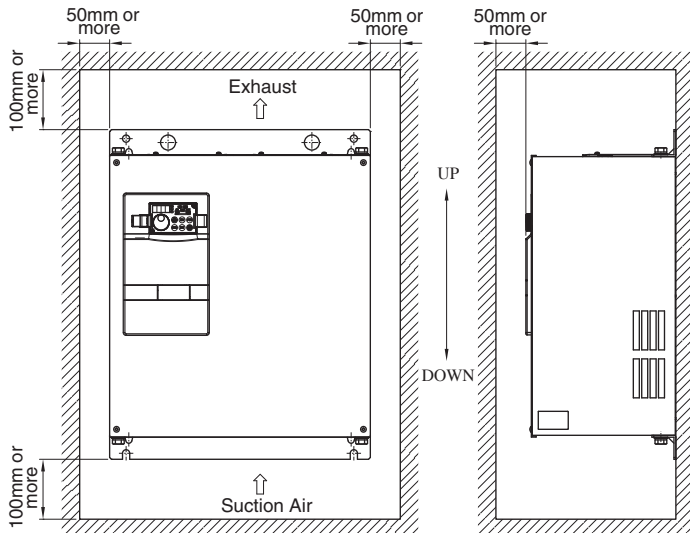

★ Consult us when installing multiple controllers next to each other.

Terminal Names/Appearance

- AMSE-2AE -B00-10
- AMSE- *BB-B00-11

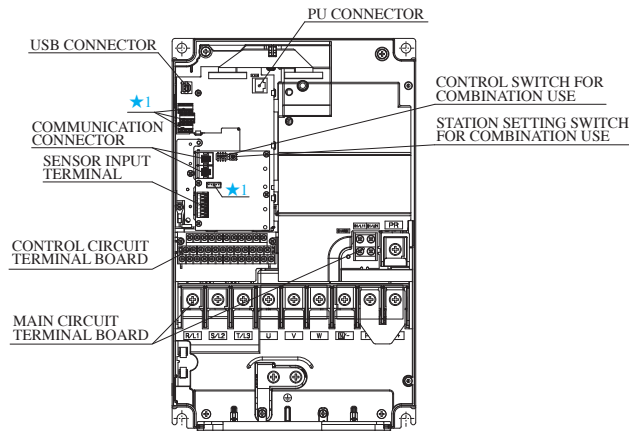

★1 These are not used in this system.

- AMSE-4AE -B00-10

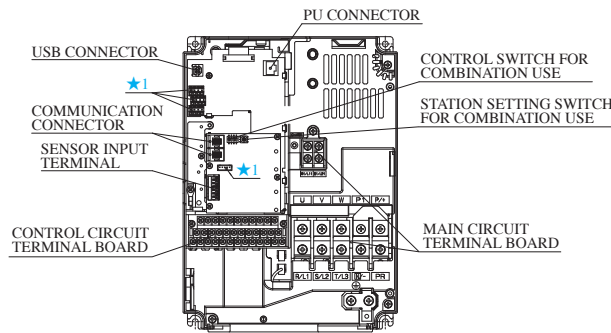

★1 These are not used in this system.

- AMSE- *DE-B00-10

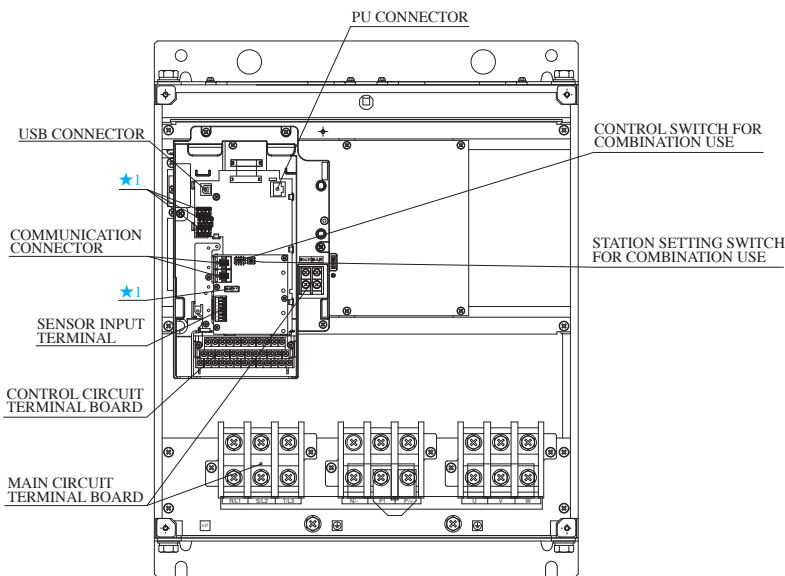

★1 These are not used in this system.

Function	Terminal Name	Terminal Channel	Description
Combination (Single Operation Allowed)	USB Connector (Type:USB B)	-	By using the serial communication function of USB, such as change of parameter, operation of monitor function is possible.
	Control Switch	1	For the manufacturer's setting. : Always OFF.
		2	Reserved.
		3	For switching single and combination operations. OFF: Combination, ON: Single
	Station Setting Switch	4	Network terminal resistance OFF:None, ON:Resistance
		0	Master station
	Communication Connector	1-F	Slave station
-		-	Connect this to the network of the ASE controller. Recommended cable: TEL-FST- * S (SANWA) or MJ-FS *(ELECOM)

Terminal Block

Connection (Use)	Signal Name	Description		
		AMSE- * AE/* BB-B00	AMSE-2DE-B00	AMSE-4DE-B00
DC Reactor for Power Factor Improvement	P1	No Connection★2		
Brake Unit	N/-	No Connection★2	FR-BU2-30K-04★2	FR-BU2-H30K-04★2

★2 Please contact Yuken, when you connect each unit or connect a DC reactor.

For the details of PU connector, sensor input terminal, consult us separately.

Wire Connection Diagram

ASE3-AA-*-B00-40**

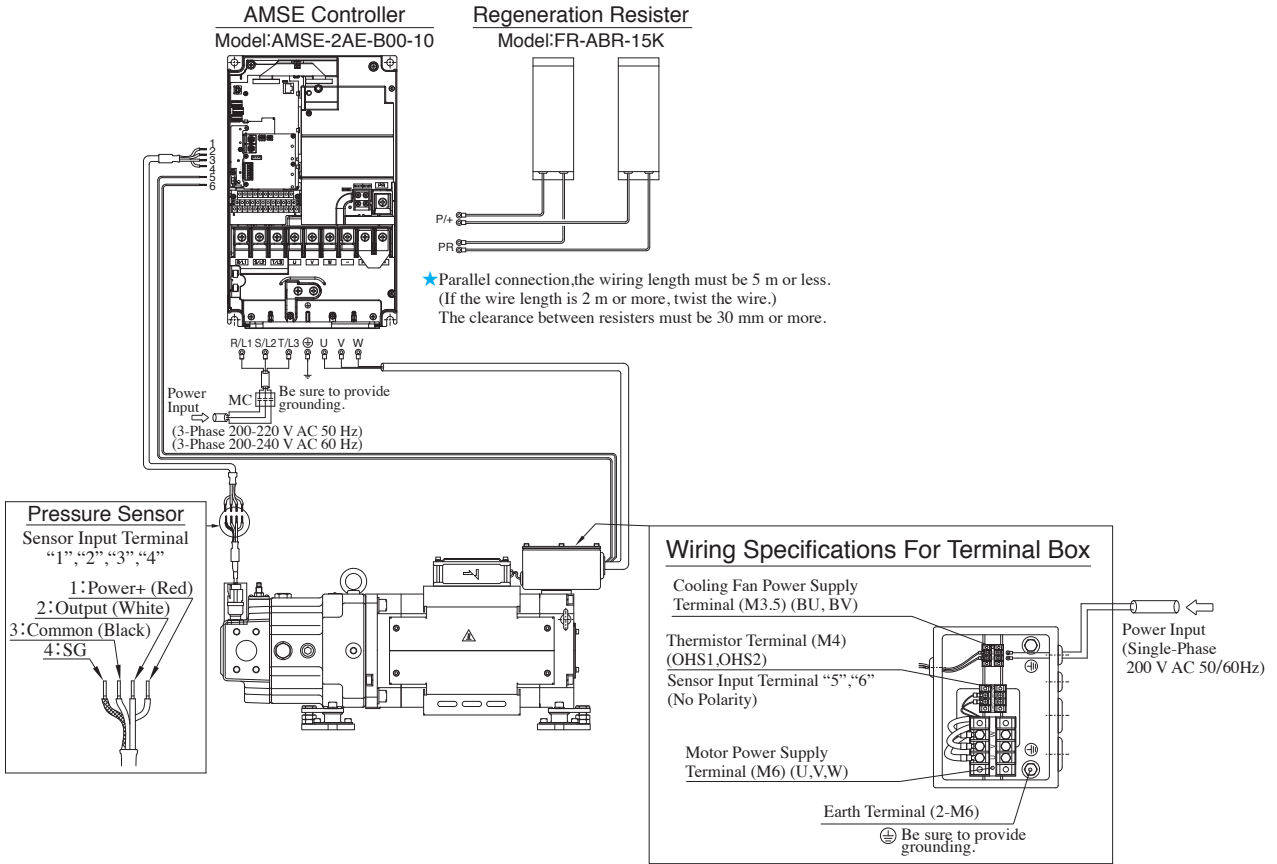

ASE3-4AA-*-B00-40**

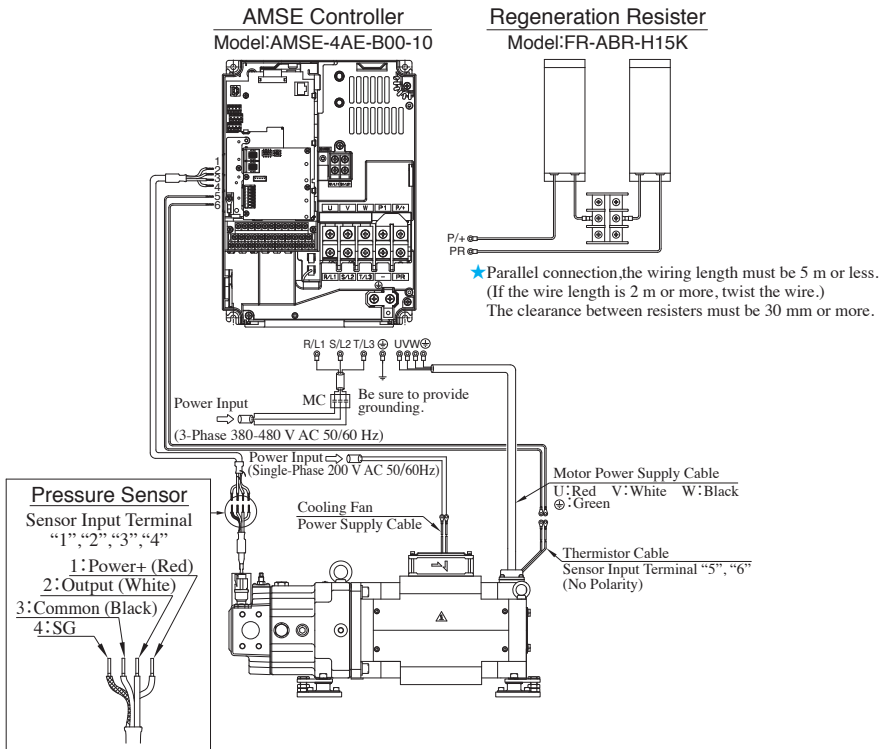

Wire Connection Diagram

ASE5-BZ-***-B00-40

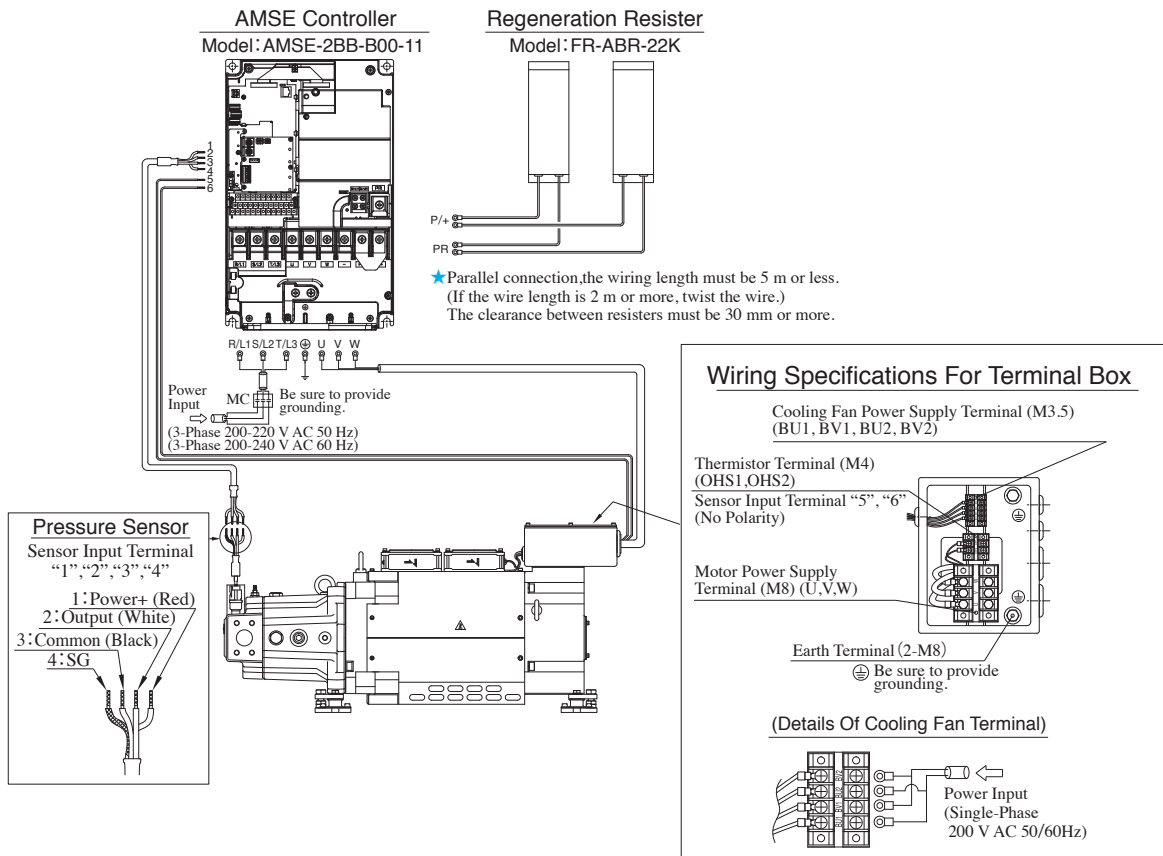

ASE5-4BZ-***-B00-40

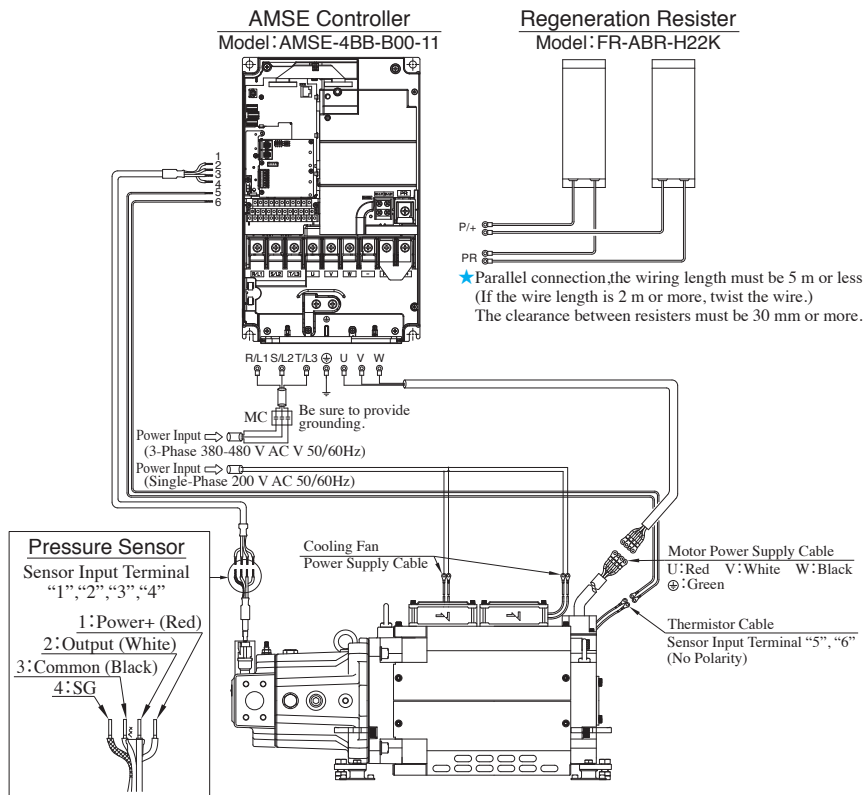

Wire Connection Diagram

ASE10-CE-*-B00-30**

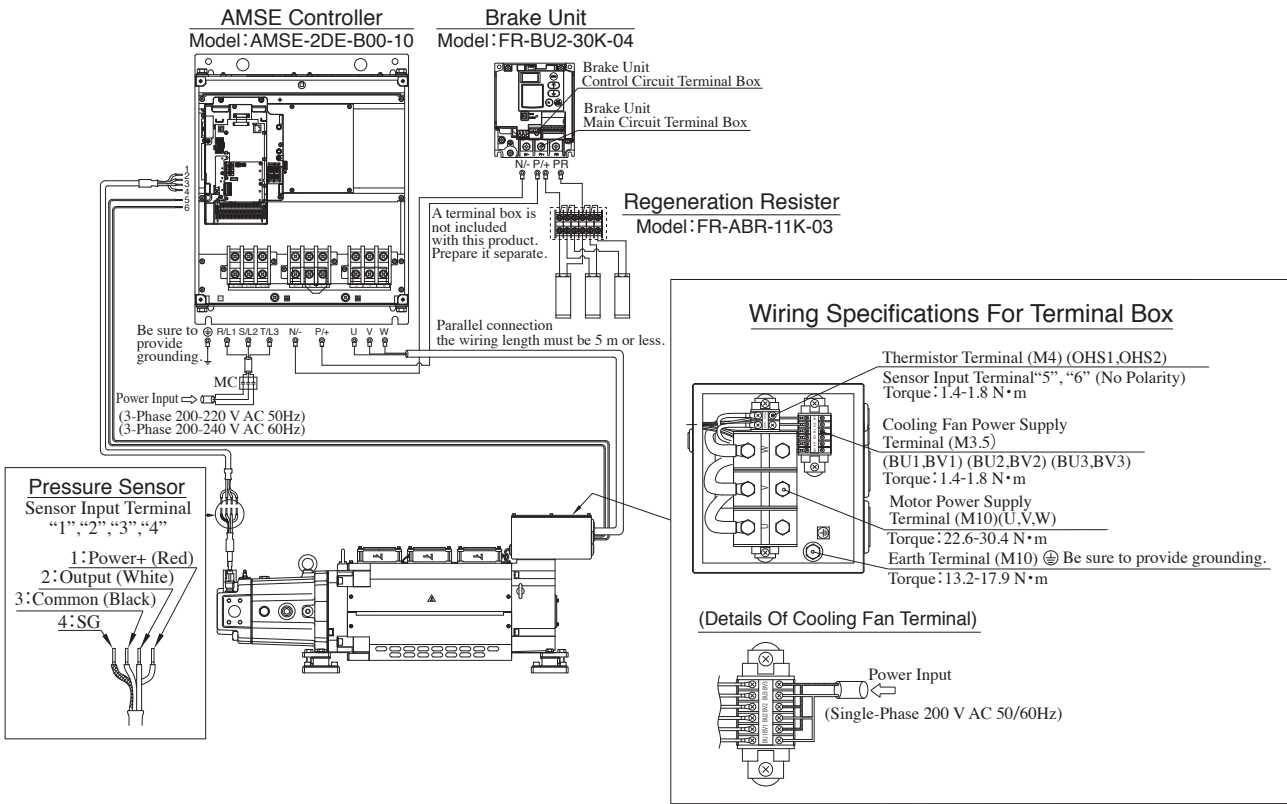

ASE10-4CE-*-B00-30**

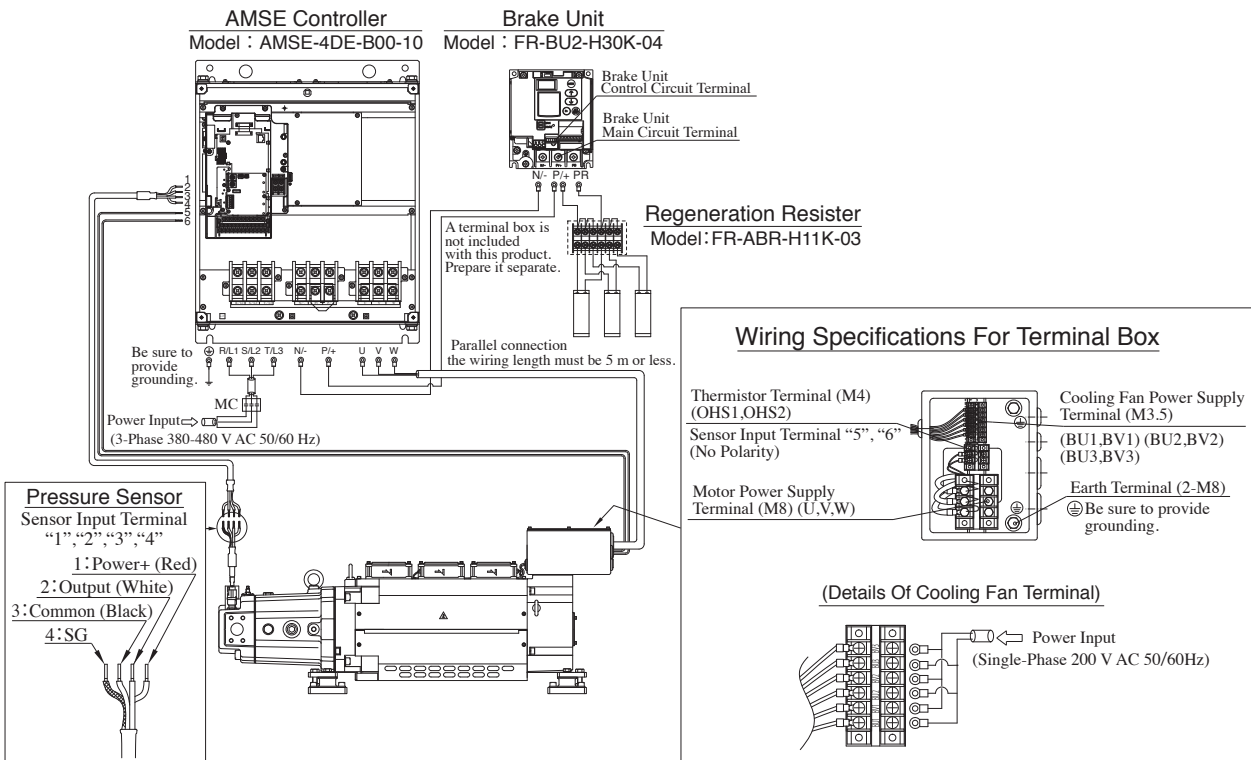

Wire Connection Diagram

ASE10W-BZ-G **** -B00-20

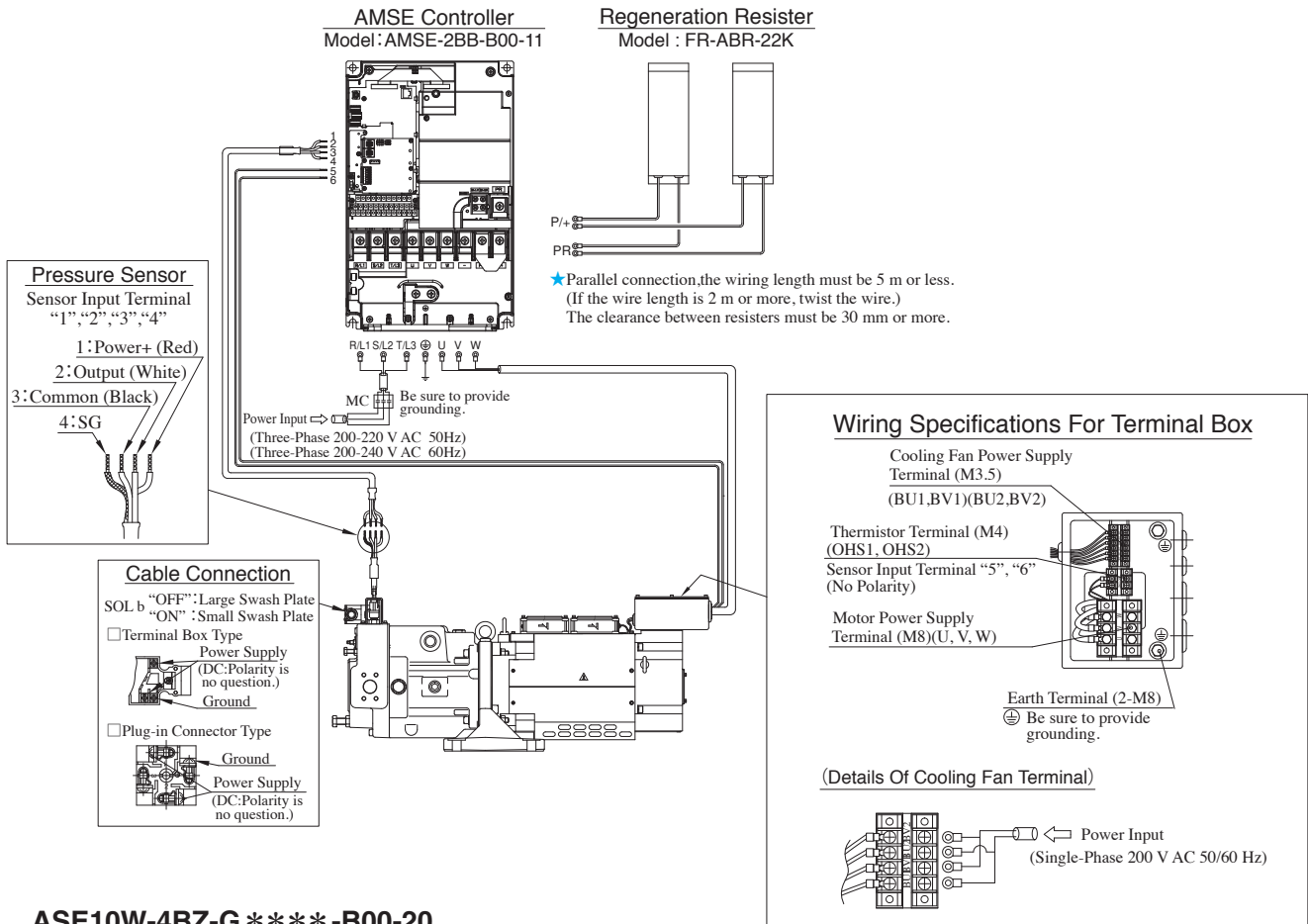

ASE10W-4BZ-G **** -B00-20

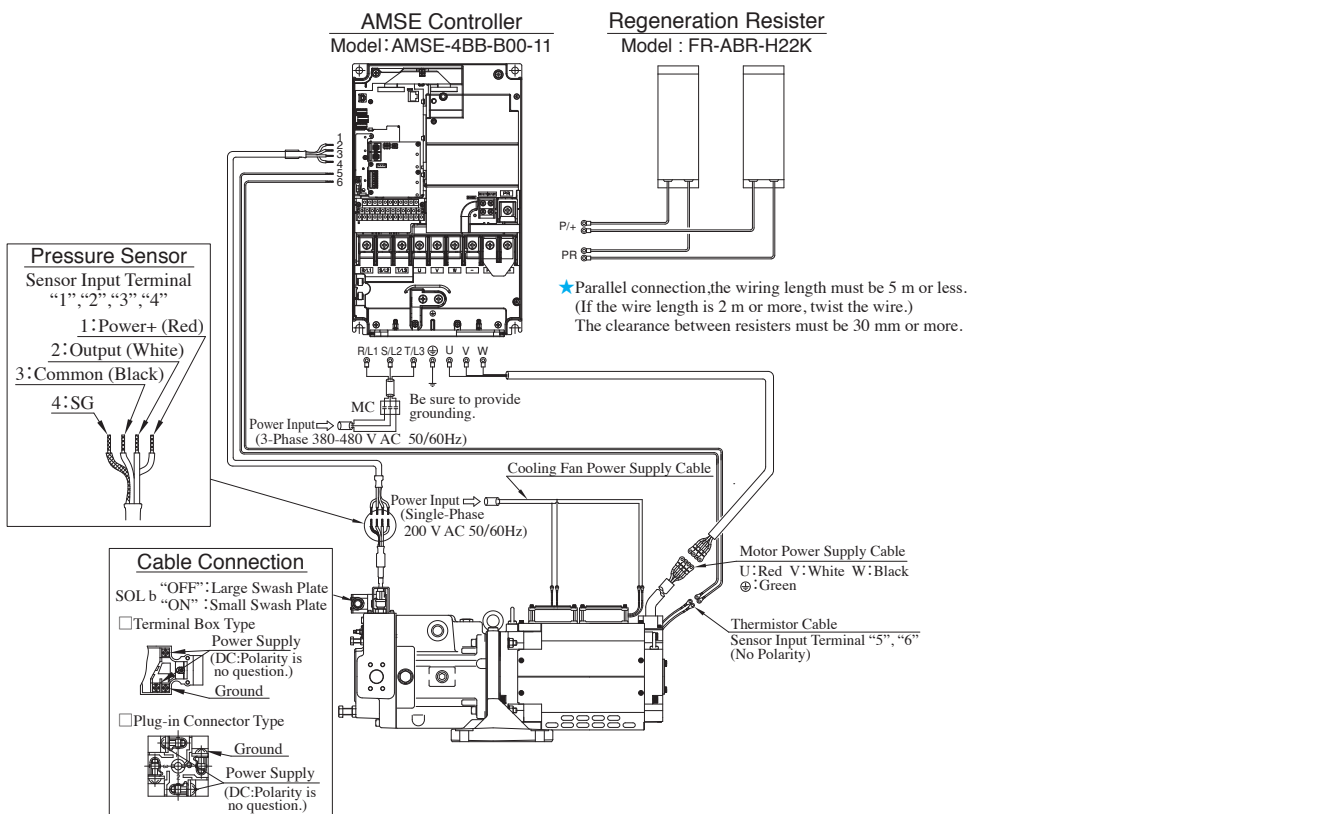

Wire Connection Diagram

ASE15W-4CE-G**-B00-20**

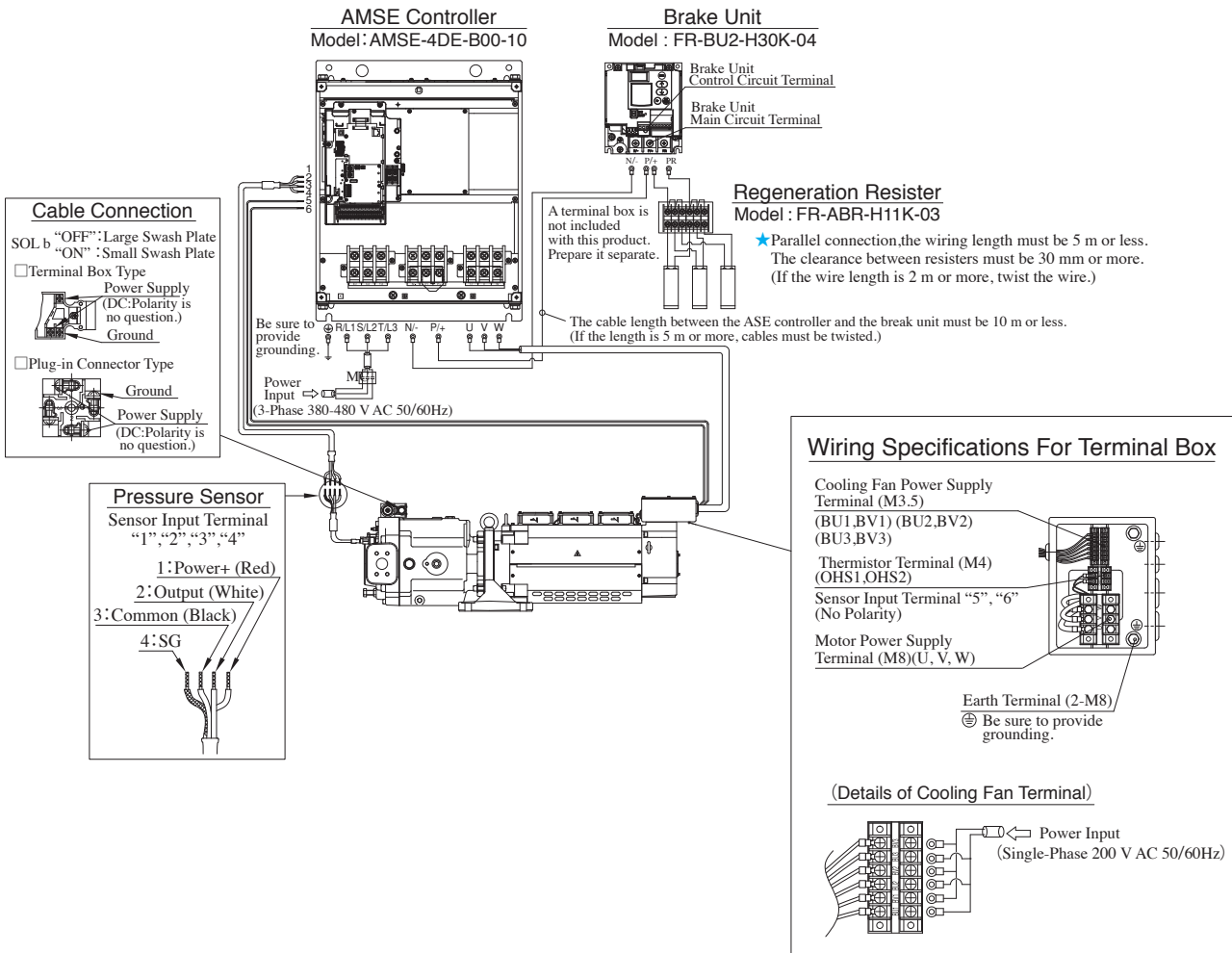

Cable Connection

SOL b "OFF": Large Swash Plate
"ON": Small Swash Plate

□ Terminal Box Type
Power Supply (DC: Polarity is no question.)
Ground

□ Plug-in Connector Type
Ground
Power Supply (DC: Polarity is no question.)

Pressure Sensor
Sensor Input Terminal
"1", "2", "3", "4"

1: Power+ (Red)
2: Output (White)
3: Common (Black)
4: SG

Wiring Specifications For Terminal Box

Cooling Fan Power Supply Terminal (M3.5)
(BU1, BV1) (BU2, BV2) (BU3, BV3)

Thermistor Terminal (M4)
(OHS1, OHS2)

Sensor Input Terminal "5", "6"
(No Polarity)

Motor Power Supply Terminal (M8)(U, V, W)

Earth Terminal (2-M8)
⊕ Be sure to provide grounding.

(Details of Cooling Fan Terminal)

Power Input (Single-Phase 200 V AC 50/60Hz)

Connectors

Control Circuit Terminal

	Cable mm ²
Control Circuit Terminal	0.75 (AWG18)

Sensor Input Terminal

	Cable mm ²
Pressure Sensor Thermistor	0.5 - 1.3 (AWG20 - 16)

Cooling Fan

	Cable mm ²
Cooling Fan Cable	2.0 (AWG14)

AMSE-2AE-**-10

Main Circuit Terminal

	HIV Cable mm ²	AWG	PVC Cable mm ²
Main Circuit Power R/L1, S/L2, T/L3	22	4	25
Motor Output Power U, V, W	22	4	25
Regeneration Resister P/+, PR	2.1	14	2.5
Earth Wire ⊕	14	6	16

AMSE-4AE-**-10

Main Circuit Terminal

	HIV Cable mm ²	AWG	PVC Cable mm ²
Main Circuit Power R/L1, S/L2, T/L3	8	8	10
Motor Output Power U, V, W	8	8	10
Regeneration Resister P/+, PR	2.1	14	2.5
Earth Wire ⊕	8	8	10

AMSE-2BB-**-11

Main Circuit Terminal

	HIV Cable mm ²	AWG	PVC Cable mm ²
Main Circuit Power R/L1, S/L2, T/L3	38	2	35
Motor Output Power U, V, W	38	2	35
Regeneration Resister P/+, PR	2.1	14	2.5
Earth Wire ⊕	22	4	25

AMSE-4BB-**-11

Main Circuit Terminal

	HIV Cable mm ²	AWG	PVC Cable mm ²
Main Circuit Power R/L1, S/L2, T/L3	14	6	16
Motor Output Power U, V, W	14	6	16
Regeneration Resister P/+, PR	2.1	14	2.5
Earth Wire ⊕	14	6	16

AMSE-2DE-**-10

Main Circuit Terminal

	LMFC Cable mm ²	HIV Cable mm ²	AWG	PVC Cable mm ²
Main Circuit Power R/L1, S/L2, T/L3	60	100	4/0	95
Motor Output Power U, V, W ⊕ (Earth Terminal)	*60			
Brake Unit Regeneration Resister P/+, N/- (PR)		5.5	10	6
Earth Wire ⊕	38	60	4	50

AMSE-4DE-**-10

Main Circuit Terminal

	HIV Cable mm ²	AWG	PVC Cable mm ²
Main Circuit Power R/L1, S/L2, T/L3	38	1	50
Motor Output Power U, V, W	38	2	50
Brake Unit Regeneration Resister P/+, N/- (PR)	3.5	12	4
Earth Wire ⊕	22	4	25

★Select LMFC wire for motor connection.

Recommended wire: EM-LMFC (Flame-retardant cross-linked polyethylene insulated flexible lead wire) made by Furukawa Electric Industrial Cable Co.,Ltd

● Pressure Sensor Cable
Consult us separately.

■ Regeneration Resister

● Specifications

AMSE Controller Model Numbers	Regeneration Resister Model	Qty.	Brake Unit Model	Permissible Regeneration W	Resistance Ω	Mass kg
AMSE-2AE-B00-	FR-ABR-15K	2		805	9 (18 Ω ×2 Parallel)	4.4kg (2.2kg×2)
AMSE-4AE-B00-	FR-ABR-H15K			870	36 (18 Ω ×2 Series)	
AMSE-2BB-B00-	FR-ABR-22K	2		1120	6.5 (13 Ω ×2 Parallel)	6.6kg (3.3kg×2)
AMSE-4BB-B00-	FR-ABR-H22K			1060	26 (52 Ω ×2 Parallel)	
AMSE-2DE-B00-	FR-ABR-11K-03	3	FR-BU2-30K-04	1500	4.3 (13 Ω ×3 Parallel)	9.6kg (3.2kg×3)
AMSE-4DE-B00-	FR-ABR-H11K-03		FR-BU2-H30K-04	1500	17.3 (52 Ω ×3 Parallel)	

- ★1. Regeneration resistors are included with the AMSE.
- ★2. Regeneration resistors may become excessively heated. Use heat-resistant and fireproof wires and avoid their contact with the resistors.
- ★3. The power (W) stamped on the regeneration resistor body is the rated value of the regeneration resistor alone, not the permissible regenerations power (W) shown in the table above.

Model:FR-ABR-15K/H15K

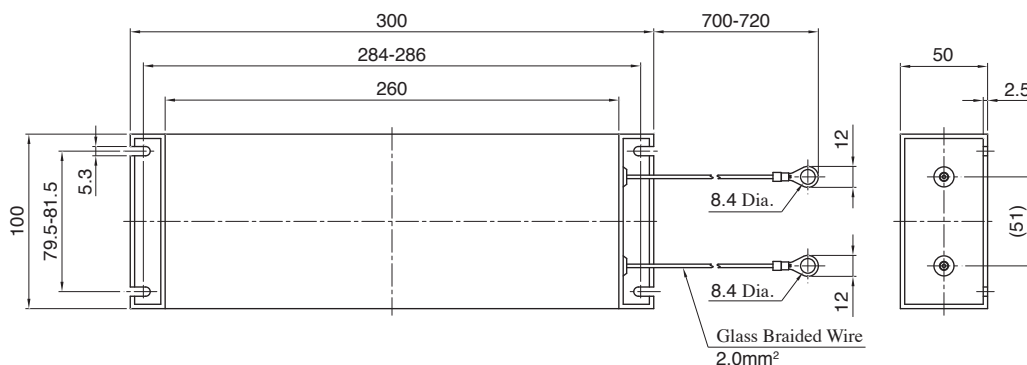

Model:FR-ABR-H22K

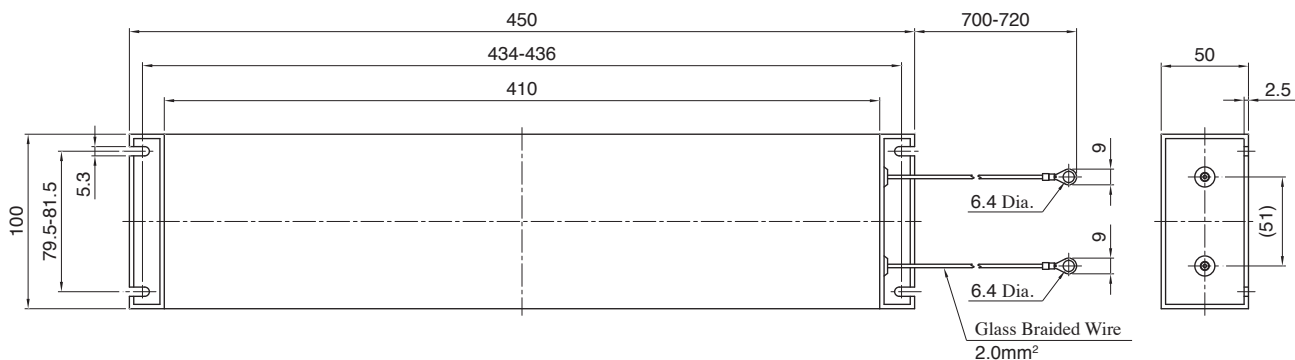

Model:FR-ABR-22K/11K-03/H11K-03

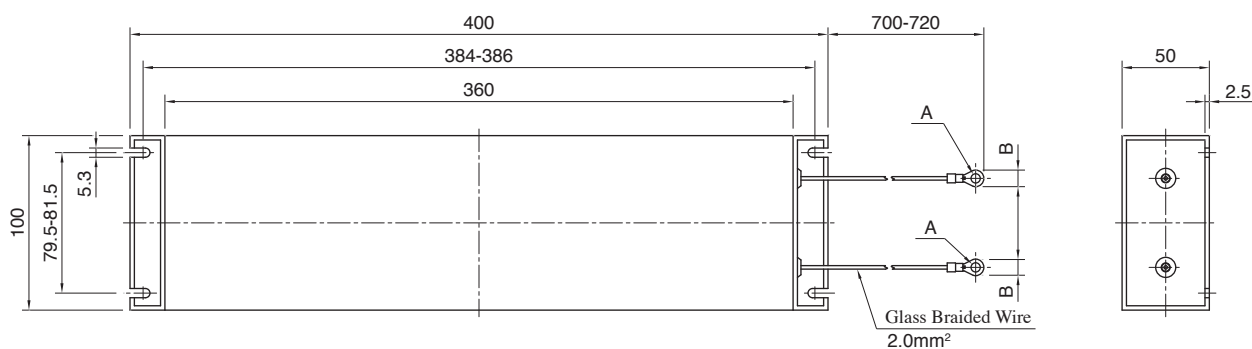

Model	A	B
FR-ABR-22K	8.4 Dia.	12
FR-ABR-11K-03/H11K-03	6.4 Dia.	9

● Customer Setting

FR-ABR-15K/22K/H22K

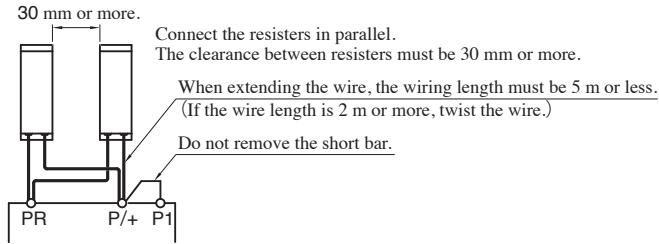

FR-ABR-H15K

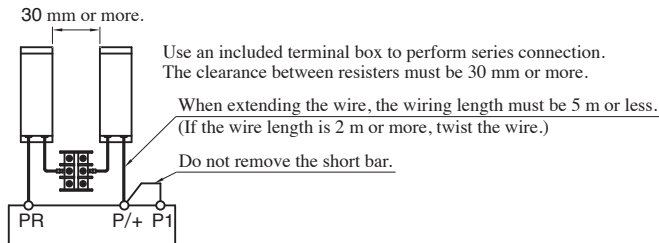

● Attachment

Terminal Box Outline Drawing

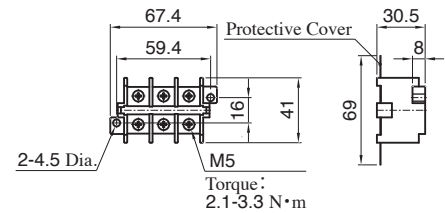

FR-ABR-11K-03 FR-ABR-H11K-03

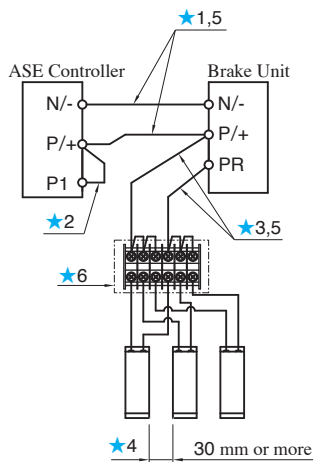

Brake Unit Outline Drawing

MODEL: FR-BU2-30K-04
FR-BU2-H30K-04

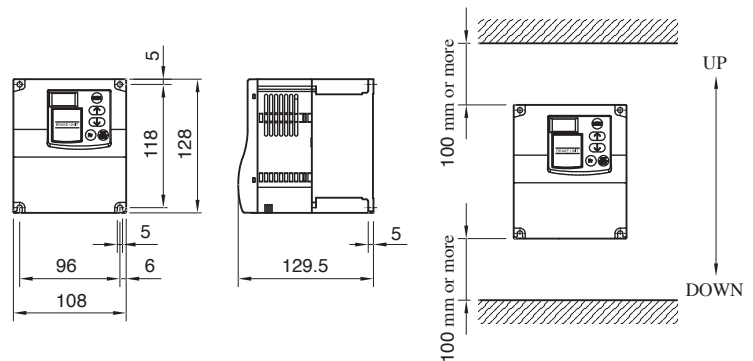

Main Circuit Terminal Assignment

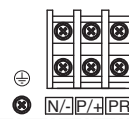

Control Circuit Terminal Assignment

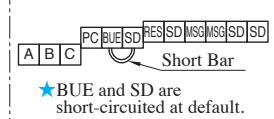

- ★1. The wiring length between the ASE controller and brake unit must be 10 m or less. (If it is 5 m or more, twist the wire.)
- ★2. Do not remove the short bar between terminals P1 and P/+ of the ASE controller.
- ★3. The wiring length between the brake unit and regenerative resistor must be 5 m or less. (If the wire length is 2 m or more, twist the wire.)
- ★4. Connect the resistors in parallel. The clearance between resistors must be 30 mm or more.
- ★5. Use a wire with the size indicated below or larger.
HIV wires and the like: 5.5 mm² AWG-10, PVC wires and the like: 6 mm² [FR-BU2-30K-04]
HIV wires and the like: 3.5 mm² AWG-12, PVC wires and the like: 4 mm² [FR-BU2-H30K-04]
- ★6. A terminal box is not included with this product. Prepare it separately.

MODEL:FR-BU2-30K-04

	MAIN CIRCUIT TERMINAL	CONTROL CIRCUIT TERMINAL
	P/+, N/-, PR, ⊕	
TERMINAL SCREW	M5	M3
TIGHTENING TORQUE	2.5 [N·m]	0.6 [N·m]

MODEL:FR-BU2-H30K-04

	MAIN CIRCUIT TERMINAL	CONTROL CIRCUIT TERMINAL
	P/+, N/-, PR, ⊕	
TERMINAL SCREW	M4	M3
TIGHTENING TORQUE	1.5 [N·m]	0.6 [N·m]

ASU Series AC Servo Motor Driven Pumps

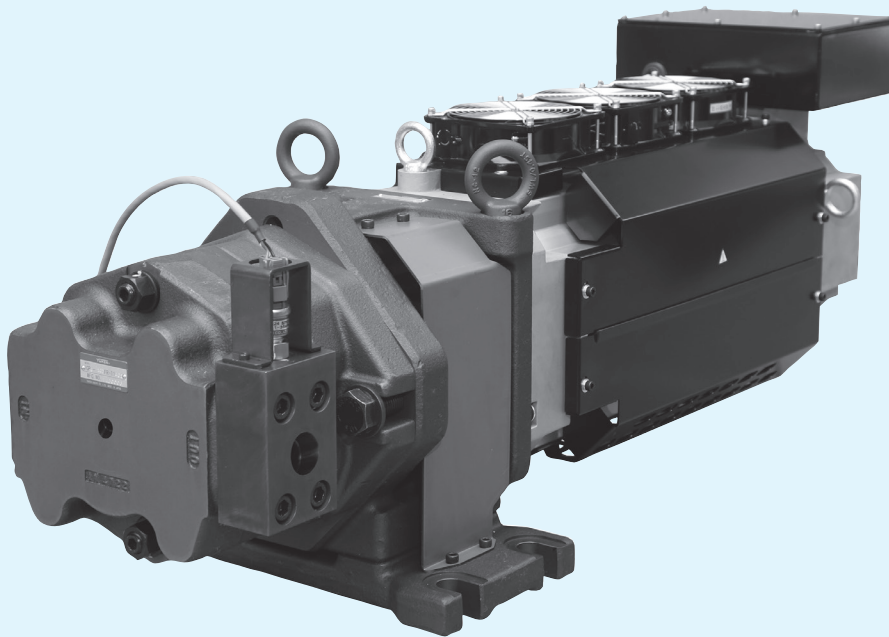

This product is exclusively use for foreign countries outside of Japan.

■ “ASU” Series AC Servo Motor Driven Pumps

Pump Type	Graphic Symbol	Geometric Displacement cm ³ /rev						Maximum Operating Pressure MPa	Page
		0	2	5	10	20	50		
ASU Series AC Servo Motor Driven Pumps		ASU6						17.5	A-257
		ASU8							
		ASU10							
		ASU13							

● Consult Yuken for "ASU" Series AC Servo Motor Driven Pumps details.

ASU Series AC Servo Motor Driven Pumps

The ASU series follows the basic concept of the ASR series rotational speed control system and achieves low noise at high speeds. The pumps of this series offer easy shaft speed control for systems that do not require as much precision, response, or repeatability as the ASR series pumps offer.

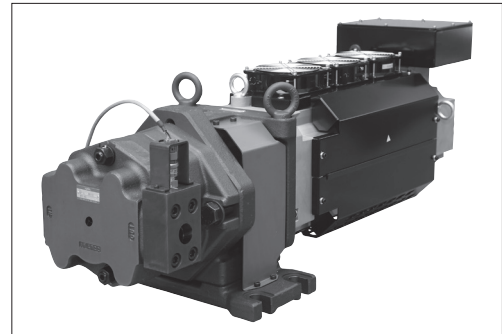

Features

- Energy saving with low heat generation

These pumps run at a rotational speed suitable for mechanical requirements, eliminating unnecessary power loss. They minimize heat generation in the fluid and allow the use of a significantly smaller reservoir.

- Low noise

The motor operates at near-zero speed during unloaded operation or pressure control, keeping the noise level extremely low. Noise at high speed is also reduced.

- Less wiring / high reliability

Use sensor-less rotational speed control.

- Digital AMSE controller that saves space and wiring

The integration of the amplifier for the servo motor and the controller saves space and wiring. The parameters can be digitally adjusted in an easy and repeatable way.

- Large flow

The AMSE controller has a combination function that supports operation with large flow up to 4080 L/min (ASU13 × 16 units).

Specifications

Descriptions		Series Number					
		ASU6	ASU8		ASU10	ASU13	
Power Capacity		BZ	BZ	CE	CE	CE	
Pump	Flow Control	Max. Flow	143.1 L/min	158.6 L/min		198.2 L/min	255 L/min
		Min. Adj. Flow	2 %				
		Hysteresis	2% or less				
		Repeatability	2% or less				
		Input Signal Voltage	124.4 L/min/5V	158.6 L/min/5V		198.2 L/min/5V	255 L/min/5V
	Max. Permissible Input Signal Voltage*	143.1 L/min/5.75V					
	Pres. Control	Max. Operating Pres.	17.5 MPa				
		Min. Adj. Pres.	0.1 MPa				
		Hysteresis	1% or less				
		Repeatability	1% or less				
Input Signal Voltage		17.5 MPa/5V					
AC Servo Motor Specifications	Rated Output	20 kW	20 kW	35 kW	35 kW		
	Insulation Class	Class F					
	Cooling System	Totally-enclosed Fan-cooling					
	Cooling Fan Power Consumption	40W(50Hz)/36W(60)Hz	40W(50Hz) 36W(60Hz)	60W(50Hz) 54W(60Hz)	60W(50Hz)/54W(60Hz)		
	Environmental Condition	Ambient Temperature	0 - +40 °C (No Freezing)				
		Ambient Humidity	80%RH or less(No Condensation)				
Mass	200 V AC Type	171 kg	173 kg	227 kg	229 kg	231 kg	
	400 V AC Type	164 kg	166 kg	222 kg	224 kg	226 kg	
Applicable Controller Model Numbers		AMSE- * BB	AMSE- * BB	AMSE- * DE	AMSE- * DE		

*By adjusting the controller, the maximum flow rate/5 V (143.1 L/min/5 V) can be set.

4 Bolt Solid Flanges (SAE) “F5” Series Pipe Flange Kits

The dimensions of the flange mounting surface are based upon SAE 4 Bolt Split Flange (Standard Pressure Series).

Model Number Designation

F5	—06	—A	—10
Series Number	Flange Size	Type of Pipe Connection	Design Standards
F5	Refer to below table	A : Threaded Connection B : Socket Welding C : Butt Welding	10

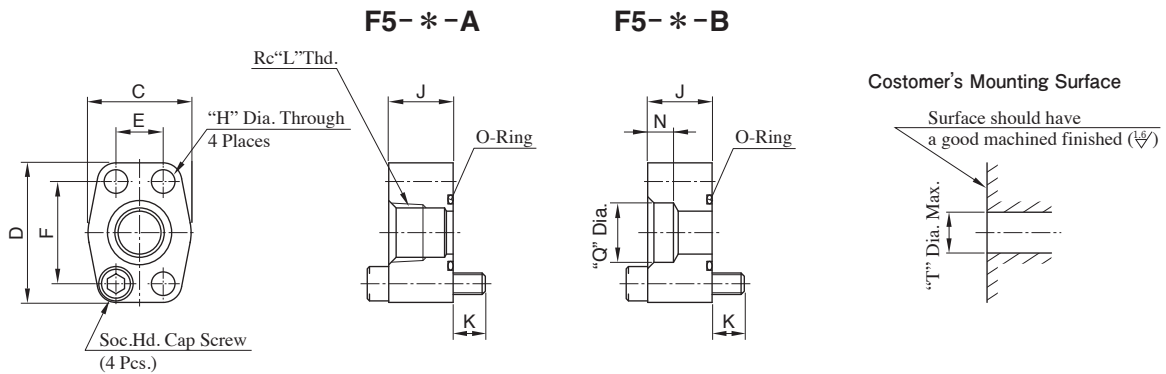

Kit Number	Piping Size	Dimension mm											O-Ring (OR NBR-90 P(G)***-N)	Socket Head Cap Screw (4 Pcs.)	Max. Operating Pressure MPa	Approx. Mass kg	Tightening Torque Nm	
		C	D	E	F	H	J	K	L	N	Q	T					Recommendation	Tolerance
F5-04W-A	3/8	40	54	17.5	38.1	8.8	30	10	3/8	-	-	13	P22	M 8 x40	28	0.5	35	
F5-04W-B									-	9	17.8							
F5-04 -A	1/2	40	54	17.5	38.1	8.8	30	10	1/2	-	-	13	P22	M 8 x40	28	0.5	35	
F5-04 -B									-	11	22.2							
F5-06X-A	3/4	48	65	22.2	47.6	8.8	30	15	3/4	-	-	19	G30	M 8 x45	28	0.7	68.5	
F5-06X-B									-	12	27.7							
F5-06 -A	3/4	48	65	22.2	47.6	11	30	15	3/4	-	-	19	G30	M10x45	28	0.7	68.5	
F5-06 -B									-	12	27.7							
F5-08W-A	3/4	55	70	26.2	52.4	11	30	15	3/4	-	-	26	G35	M10x45	28	0.9	68.5	
F5-08W-B									-	12	27.7							
F5-08 -A	1	55	70	26.2	52.4	11	30	15	1	-	-	26	G35	M10x45	28	0.9	68.5	
F5-08 -B									-	14	34.5							
F5-10 -A	1 1/4	64	80	30.2	58.7	11	38	17	1 1/4	-	-	32	G40	M10x55	28	1.2	118	
F5-10 -B									-	16	43.2							
F5-12 -A	1 1/2	72	94	35.7	69.9	13.5	38	17	1 1/2	-	-	38	G50	M12x55	21	1.5	118	
F5-12 -B									-	18	49.1							
F5-16W-A	1 1/2	85	102	42.9	77.8	13.5	38	17	1 1/2	-	-	48	G60	M12x55	21	1.8	118	
F5-16W-B									-	18	49.1							
F5-16 -A	2	85	102	42.9	77.8	13.5	38	17	2	-	-	51	G65	M12x55	17.5	1.7	118	
F5-16 -B									-	20	61.1							
F5-20 -A	2 1/2	102	114	50.8	88.9	13.5	48	17	2 1/2	-	-	63	G75	M12x65	17.5	2.0	287	
F5-20 -B									-	22	77.1							
F5-24 -A	3	116	135	61.9	106.4	17.5	53	17	3	-	-	76	G85	M16x70	3.5	2.7	287	
F5-24 -B									-	25	90.0							
F5-28 -A	3 1/2	134	153	69.9	120.7	17.5	53	17	3 1/2	-	-	88	G100	M16x70	3.5	3.4	287	
F5-28 -B									-	28	102.8							
F5-32 -A	4	150	162	77.8	130.2	17.5	53	17	4	-	-	101	G115	M16x70	3.5	3.7	287	
F5-32 -B									-	28	115.5							

★1. Approx. mass is the value including socket head cap screw (4 pcs.).

★2. The values of tightening torque above apply to when these flanges are used for pressure line.

F5- *-C

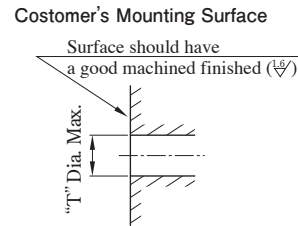
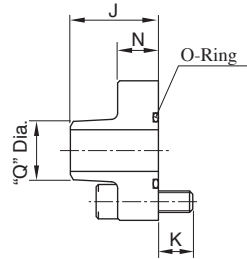
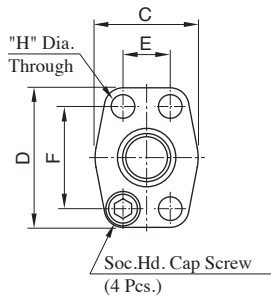

Kit Number	Piping Size	Dimension mm										O-Ring (OR NBR-90 P(G)* *-N)	Socket Head Cap Screw (4 Pcs.)	Max. Operating Pressure MPa	Approx. Mass kg	Tightening Torque	
		C	D	E	F	H	J	K	N	Q	T					Recommendation	Tolerance
F5-04-C	1/2	40	54	17.5	38.1	8.8	39	13	17	21.7	13	P22	M 8 x30	28	0.25	35	±10%
F5-06-C	3/4	48	65	22.2	47.6	11	41	16	19	27.2	19	G30	M10x35	28	0.35	68.5	
F5-08-C	1	55	70	26.2	52.4	11	42	16	19	34	26	G35	M10x35	28	0.45	68.5	
F5-10-C	1 1/4	64	80	30.2	58.7	11	44	16	19	42.7	32	G40	M10x35	28	0.63	68.5	
F5-12-C	1 1/2	72	94	35.7	69.9	13.5	50	18	22	48.6	38	G50	M12x40	21	1.3	118	
F5-16-C	2	85	102	42.9	77.8	13.5	50	18	22	60.5	51	G65	M12x40	17.5	1.3	118	
F5-20-C	2 1/2	102	114	50.8	88.9	13.5	50	20	25	76.3	63	G75	M12x45	14	1.4	118	

★1. Approx. mass is the value including socket head cap screw (4 pcs.).

★2. The values of tightening torque above apply to when these flanges are used for pressure line.

Air Bleed Valves

These air bleed valves are designed to use, at the start-up of the pumps, to bleed off the air enclosed in the suction line or the other lines in the system.

Specifications

Model Numbers	ST 1004-2-1002	ST 1004-5-10	ST 1004-10-10
Port Size	Rc 3/8 Thd.		
Max. Operating Pressure	25 MPa		
Reseating Pressure	0.15 MPa		
Cracking Pressure	0.34 MPa		
Flow Rate to Reseating	2 L/min	5 L/min	10 L/min
Range of Usage to Pump Output Flow	For Under 20 L/min	For 20 to 75 L/min	For Over 75 L/min



Graphic Symbols

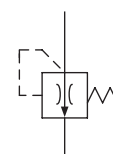

4 Bolt Solid Flanges (SAE) “F6” Series Pipe Flange Kits

The dimensions of the flange mounting surface are based upon SAE 4 Bolt Split Flange (High Pressure Series).

Specifications

Max. Operating Pressure..... 42 MPa

However, Rc Threaded Connection Type..... 31 MPa

Model Number Designation

F6	-04W	-A	-M	-10
Series Number	Flange Size	Type of Pipe Connection	Type of Mounting Bolt	Design Standards
F6	Refer to below table	A : Threaded Connection B : Socket Welding	M : Metric Thd.	10

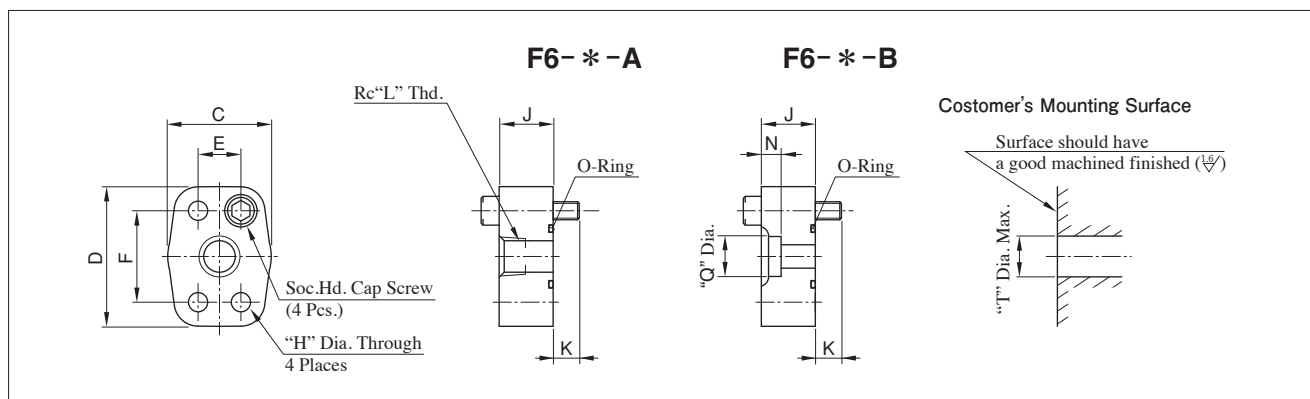

Kit Number	Piping Size	Dimension mm										O-Ring (OR NBR-90 P(G) * * -N)	Socket Head Cap Screw (4 Pcs.)	Approx. Mass kg	Tightening Torque Nm		
		C	D	E	F	H	J	K	L	N	Q				Recommendation	Tolerance	
F6-04W-A	3/8	48	56.5	18.2	40.5	8.8	28	12	3/8	-	-	15	P22	M 8 x40	0.4	35	
F6-04W-B									-	9	17.8						
F6-04 -A	1/2	48	56.5	18.2	40.5	8.8	28	12	1/2	-	-	15	P22	M 8 x40	0.4	35	
F6-04 -B									-	11	22.2						
F6-06W-A	1/2	57.5	77.5	23.8	50.8	11	30	15	1/2	-	-	21	G30	M10x45	0.9	68.5	
F6-06W-B									-	11	22.2						
F6-06 -A	3/4	57.5	77.5	23.8	50.8	11	30	15	3/4	-	-	21	G30	M10x45	0.9	68.5	
F6-06 -B									-	12	27.7						
F6-08W-A	3/4	65	81	27.8	57.2	13.5	30	15	3/4	-	-	26	G35	M12x45	1.1	68.5	
F6-08W-B									-	12	27.7						
F6-08 -A	1	65	81	27.8	57.2	13.5	30	15	1	-	-	26	G35	M12x50	1.1	68.5	
F6-08 -B									-	14	34.5						
F6-10W-A	1	72	95	31.8	66.7	13.5	34	16	1	-	-	34	G40	M12x50	1.3	118	
F6-10W-B									-	14	34.5						
F6-10 -A	1 1/4	72	95	31.8	66.7	13.5	34	16	1 1/4	-	-	34	G40	M12x55	1.3	118	
F6-10 -B									-	16	43.2						
F6-12W-A	1 1/4	90	113	36.5	79.4	17.5	34	21	1 1/4	-	-	44	G50	M16x55	1.5	287	
F6-12W-B									-	16	43.2						
F6-12 -A	1 1/2	90	113	36.5	79.4	17.5	34	21	1 1/2	-	-	44	G50	M16x60	1.5	287	
F6-12 -B									-	18	49.1						

★1. Approx. mass is the value including socket head cap screw (4Pcs.).

★2. The values of tightening torque above apply to when these flanges are used for pressure line.